

Swedlinghaus dal 1950®

SEGAOSI INOX





CE PROFESSIONALE

1600 - 1800



2080 - 2460



-  *S/steel bone bandsaw*
-  *Scie à os - inox*
-  *Knochenbandsäge aus Edelstahl*
-  *Sierra de cinta para huesos inoxidable*

mod. SEG 1600 I
mod. SEG 1800 I
mod. SEG 2080 I
mod. SEG 2460 I





SEGAOSSI INOX

mod. SEG 1600 I • mod. SEG 1800 I • mod. SEG 2080 I • mod. SEG 2460 I

I segaossi SWEDLINGHAUS sono strumenti professionali, robusti e facili da utilizzare. Struttura realizzata in acciaio inox AISI 304, con cassetto raccogliatore interbloccato nello sportello, puleggia superiore rimovibile. Completo di spingicarne, porzionatore, micro di sicurezza sulla porta e scheda a bassa tensione. Pulegge costruite in alluminio e sportello facilmente rimovibile per agevolare la pulizia.

 The SWEDLINGHAUS bone bandsaws, designed for a professional use, are heavy-duty and easy to operate. AISI304 stainless steel body, door-blocked waste tray, easily removable door for faster cleaning. Removable upper pulley. Supplied with meat pusher, portion gauge, door safety micro switch and low tension board. Aluminium pulleys.

 Les scies à os SWEDLINGHAUS sont des outils professionnels, robustes et simples d'utilisation. Construction en acier inox AISI304, bac à sciure bloqué dans la porte, porte démontable pour une hygiène optimale. Poulie supérieure démontable. Équipée de pousse-viande, guide de sciage, micro-interrupteur de sécurité de porte, carte moteur basse tension. Poulie en aluminium.

 Die Knochenbandsägen SWEDLINGSHAUS sind professionelle und robuste Geräte, einfach zu benutzen. Seine Struktur ist aus Edelstahl AISI 304 gefertigt, mit einem in der Klappe versperren Sammelfach ausgestattet. Klappe einfach ausziehbar, um den Reinigungsprozess zu erleichtern. Obere Riemenscheibe ausziehbar. Sie ist komplett mit Wolfstopfer, Portionsschneider, Microswitch an der Klappe und Niederspannungs-Leistungsschalter. Riemenscheiben aus Aluminium hergestellt.

 Las Sierras de Cinta para huesos SWEDLINGHAUS son instrumentos profesionales de estructura robusta y fáciles de utilizar. La estructura esta realizada en acero inoxidable AISI 304, con cajón recolector fijado a la puerta. Polea superior removible. Dotado de empuja-carne, porcionador, micro interruptor de seguridad en la puerta y plaqueta de baja tensión. Poleas construídas en aluminio y puerta de simple remoción para facilitar la limpieza

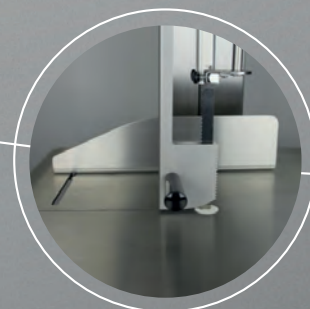
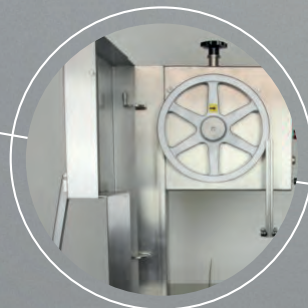
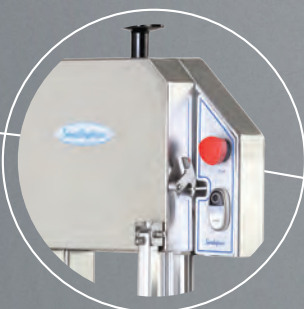

LE ALTRE VERSIONI

1. SEGAOSSI VERNICIATO

Painted bone bandsaw - Scie à os verni - lackierte Knochenbandsäge - Sierra de cinta para huesos pintada

2. SEGAOSSI ANODIZZATO

Anodized bone bandsaw - Scie à os anodisée - Eloxierte Knochenbandsäge - Sierra de cinta para huesos anodizada



LA SCHEDA TECNICA

- A DISTANZA PIEDINI**
Distance between feet / Distance entre les pieds
Abstand zwischen der Füßchen / Distancia entre los pies
- B INGOMBRO MASSIMO LARGHEZZA**
Overall width dimension / Dimension d'encombrement largeur
Maximaler Platzbedarf-Breite / Medida ancho máximo
- C DISTANZA PIEDINI**
Distance between feet / Distance entre les pieds
Abstand zwischen der Füßchen / Distancia entre los pies
- D INGOMBRO MASSIMO IN LUNGHEZZA**
Overall length dimensions / Dimensions d'encombrement longueur
maximaler Platzbedarf - Länge / Medidas largo máximo
- E ALTEZZA**
Height / Hauteur
Höhe / Altura

	SEG 1600 I	SEG 1800 I	SEG 2080 I	SEG 2460 I
A	380 mm	380 mm	550 mm	640 mm
B	610 mm	610 mm	720 mm	826 mm
C	420 mm	420 mm	430 mm	450 mm
D	530 mm	530 mm	600 mm	720 mm
E	890 mm	995 mm	1550 mm	1692 mm

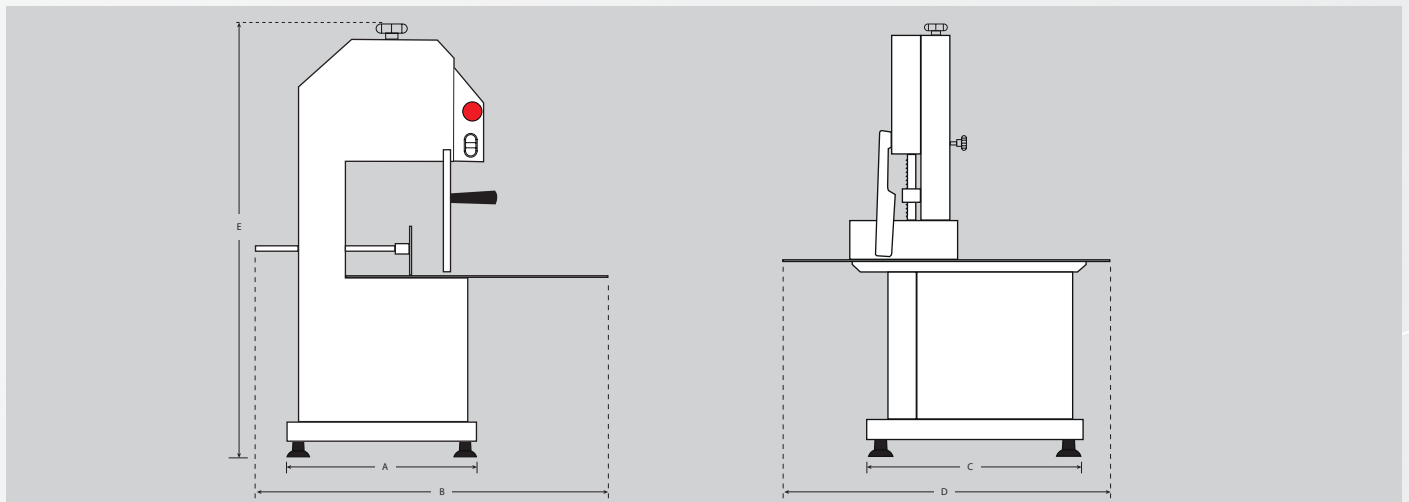

MODELLO	SEG 1600 I	SEG 1800 I	SEG 2080 I	SEG 2460 I
LUNGHEZZA NASTRO Blade length / Longueur lame Länge des Bandes / Largo cinta	1610 mm	1800 mm	2080 mm	2460 mm
ALTEZZA UTILE TAGLIO Cutting height / Hauteur de coupe Nutzbare Höhe der Schneide / Altura útil de corte	180 mm	265 mm	270 mm	330 mm
LARGHEZZA UTILE TAGLIO Cutting width / Largeur de coupe Nutzbare Breite der Schneide / Ancho útil de corte	165 mm	165 mm	230 mm	270 mm
DIMENSIONI PIANO Worktop dimensions / Dimensions plateau de travail Ausmasse der Platte / Medidas de base de trabajo	480x530 mm	480x530 mm	600x550 mm	720x660 mm
ALIMENTAZIONE Power supply / Alimentation Stromversorgung / Alimentación	V 230-400	V 230-400	V 230-400	V 230-400
POTENZA MOTORE Motor / Moteur Motorleistung / Potencia Motor	1 HP Kw 0,75	1 HP Kw 0,75	2 HP Kw 1,50	2 HP Kw 1,50
PESO Weight / Poids Gewicht / Peso	55 kg	58 kg	87 kg	115 kg
DIMENSIONE IMBALLO Packing dimensions / Dimensions emballage Ausmass der Verpackung / Dimensiones embalaje	550x1010x750 mm	550x1010x750 mm	920x850x2000 mm	920x850x2000 mm

GLI OPTIONALS

1. LAMA

Blade
Lame
Klinge
Cinta

2. CAVALLETTO (MOD. 1600 e 1800)

Base
Établi
Gestell
Caballete

3. VOLTAGGI SPECIALI

Special voltages
Voltages spéciales
Sonderspannungen
Voltajes especiales

4. PIANO SCORREVOLE (MOD. 2080 e 2460)

Sliding worktop
Table coulissante
Gleitende Fläche
Base de trabajo corrediza



Swedlinghaus[®]