

**STATUS SCIENTIFIC CONTROLS**

Issue: 5

Date: 21/1/19

Firmware: V1.0.7



# **Installation, Commissioning & Routine Gas Testing Manual**

## **Gas Detector Type FGD4**



# Declaration of Conformity

We declare that, on the date the equipment accompanied by this declaration is placed on the market, the equipment conforms with all technical and regulatory requirements of the directives listed below.

**Description of Equipment:**

The FGD4 Series of Fixed Gas Detectors for the detection of Oxygen, Toxic or Flammable gases.  
Non-certified apparatus for safe area use only.

**2004/108/EC – Electromagnetic Compatibility****Harmonised Standards Used:**

**EN50270:2006** Electromagnetic compatibility - Electrical apparatus for the detection and measurement of combustible gases, toxic gases or oxygen. (Performance criterion 'C' )

**EN61000-6-2:2005** Electromagnetic compatibility. Generic standards. Immunity standard for industrial environments.

**EN61000-6-4:2007** Electromagnetic compatibility. Generic emission standard. Industrial environment.

**2006/95/EC – Low Voltage Directive (LVD)****Harmonised Standards Used:**

**EN 61010-1:2010** Safety requirements for electrical equipment for measurement, control, and laboratory use -- Part 1: General requirements.

**Place of Manufacture:**

Mansfield, Nottinghamshire, UK.

**ISO 9001:2015 Quality Management System:**

Certificate No. GB93/1938

Authorised Signatory to this declaration, on behalf of the manufacturer:

Name: David Stuttard Title: Managing Director

Address: Status Scientific Controls Ltd, Hermitage Lane Industrial Estate, Kings Mill Way  
Mansfield, Nottinghamshire, NG18 5ER, United Kingdom

Signature



Date: 21/1/19



# STATUS SCIENTIFIC CONTROLS

Installation, Commissioning & Routine Gas Testing  
FGD4 Gas Detector



## CONTENTS

<b>1.</b>	<b>PACKAGE CONTENTS .....</b>	<b>6</b>
<b>2.</b>	<b>SCOPE OF THE MANUAL .....</b>	<b>6</b>
<b>3.</b>	<b>DESCRIPTION .....</b>	<b>7</b>
3.1.	GAS TYPES .....	7
<b>4.</b>	<b>INSTALLATION .....</b>	<b>8</b>
4.1.	CABLE ENTRIES .....	8
4.2.	FGD4 CONNECTIONS .....	8
4.3.	WIRING DETAILS .....	9
4.3.1.	FGD4 Toxic current sink .....	9
4.3.2.	FGD4 Toxic current source .....	9
4.3.3.	FGD4 Infrared current sink .....	10
4.3.4.	FGD4 Infrared current source .....	10
<b>5.</b>	<b>COMMISSIONING .....</b>	<b>11</b>
5.1.	APPLYING POWER .....	11
<b>6.</b>	<b>INITIAL GAS TESTING .....</b>	<b>12</b>
6.1.	ZERO GAS .....	12
6.2.	TEST GAS .....	14
6.2.1.	Gas connection points .....	14
6.2.2.	Sampling time .....	14
6.2.3.	Suggested calibration gas levels .....	14
<b>7.</b>	<b>CALIBRATION .....</b>	<b>15</b>
7.1.	SENSOR ZERO .....	15
7.2.	SENSOR SPAN .....	16
7.3.	CALIBRATION / CONFIGURATION KEYPAD .....	17
7.4.	MENU MODE SELECTION .....	19
7.4.1.	E : 1 – Sensor Zero .....	20
7.4.2.	E : 2 – Sensor Span .....	20
7.4.3.	E : 3 – Sensor Fsd .....	20
7.4.4.	E : 4 – Output Zero (4mA) .....	20
7.4.5.	E : 5 – Output Span (20mA) .....	20
7.4.6.	E : 8 – Factory restore .....	21
7.4.7.	E : 9 – Engineer diagnostics .....	21
7.4.8.	E : 17 – Sensor gain .....	22
7.4.9.	E : 19 – Positive Zero Suppression .....	23
7.4.10.	E : 20 – Negative Zero Suppression .....	23
7.4.11.	E : 25 – Positive Zero Temperature Compensation .....	24
7.4.12.	E : 34 – Positive Span Temperature Compensation .....	24
7.4.13.	E : 35 – Negative Span Temperature Compensation .....	24
7.4.14.	E : 36 – Positive Zero Temperature Compensation .....	24
7.4.15.	E : 77 – Firmware Version .....	24
<b>8.</b>	<b>CALIBRATION .....</b>	<b>25</b>
8.1.	SENSOR CALIBRATION .....	25
8.1.1.	Sensor Zero .....	25
8.1.2.	Sensor Span .....	26

# STATUS SCIENTIFIC CONTROLS

Installation, Commissioning & Routine Gas Testing  
FGD4 Gas Detector



8.2.	ANALOGUE OUTPUT CALIBRATION .....	27
8.2.1.	<i>Analogue Output Zero</i> .....	28
8.2.2.	<i>Analogue Output Span</i> .....	28
9.	<b>ROUTINE GAS TESTING</b> .....	<b>29</b>
10.	<b>FUSES</b> .....	<b>30</b>
11.	<b>SPECIFICATION</b> .....	<b>30</b>
12.	<b>DIMENSIONS &amp; MOUNTING DETAILS</b> .....	<b>31</b>

# STATUS SCIENTIFIC CONTROLS

Installation, Commissioning & Routine Gas Testing  
FGD4 Gas Detector



## 1. PACKAGE CONTENTS

The FGD4 is supplied in a box containing the following items:-

<b>Description</b>	<b>Stock No</b>
FGD4 Gas Detector	*
Installation manual	**
Calibration certificate	

Optional:-

Weather guard  
Calibration / Configuration Keypad

\* Refer to [www.status-scientific.com](http://www.status-scientific.com) for Stock No's for various gas types.

\*\* The manual may be supplied on a CD

## 2. SCOPE OF THE MANUAL

This manual relates specifically to the version of the FGD4 gas detector fitted with one of the following sensor types:-

- An Oxygen sensor.

Or

- An electrochemical Toxic sensor.

Or

- An Infrared sensor.

## 3. DESCRIPTION

The FGD4 is a fixed gas detector for use in non-explosive atmospheres.

The unit comprises an instrument housing having one cable gland entry.

The housing containing the gas sensor has an M27 thread and is screwed into the bottom of the unit. The sensor housing itself is a certified component and must not be removed in service.

The main electrical features of the unit are:-

- Power supply – 8 to 24 volts dc (non-intrinsically safe)
- Loop powered 4 to 20mA dc
- Gland entry threads available – 20mm, 1/2" or 3/4" NPT

### 3.1. Gas types

Versions of the FGD4 Oxygen Toxic are available for detection of gases, fitted with any of the following sensor types:-

- O<sub>2</sub>, H<sub>2</sub>S, CO, SO<sub>2</sub> and CO<sub>2</sub>



## 4. INSTALLATION

To ensure effective gas detection, the FGD4 must be located at a height appropriate to the density of the target gas relative to air.

### 4.1. Cable entries

The cable entry threads is 20mm female.

The FGD4 enclosure is manufactured from injection moulded poly carbonate and as such care should be taken not to over-tighten the gland.

### 4.2. FGD4 connections

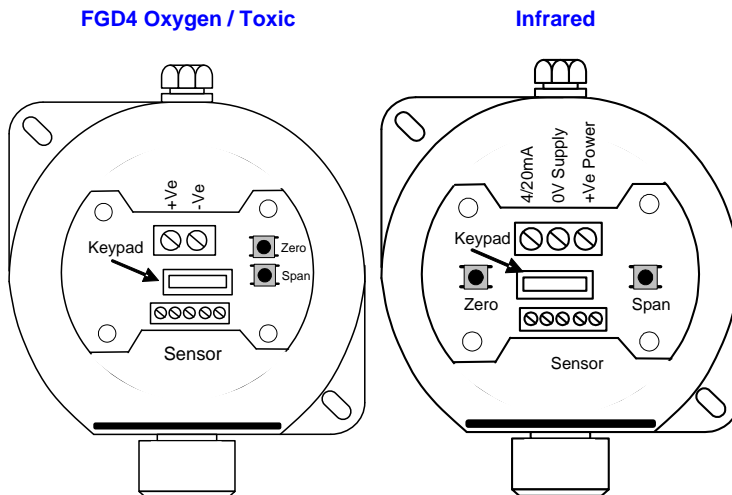

## 4.3. Wiring details

The infrared gas detector is a 4 to 20 mA loop powered device that operates from a supply of 8 – 24 volt dc supply and as such only requires two wires.

### 4.3.1. FGD4 Toxic current sink

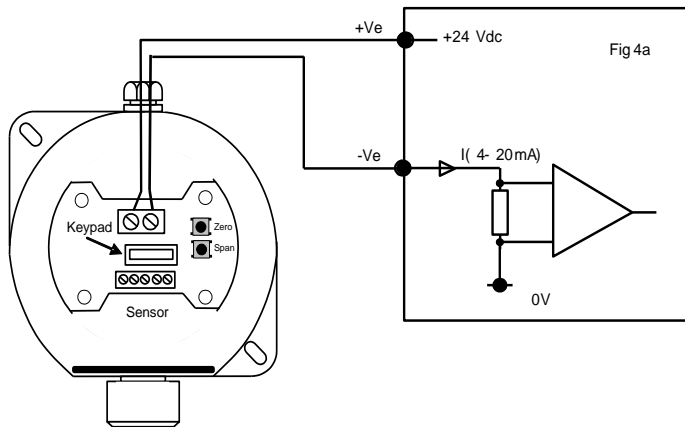

### 4.3.2. FGD4 Toxic current source

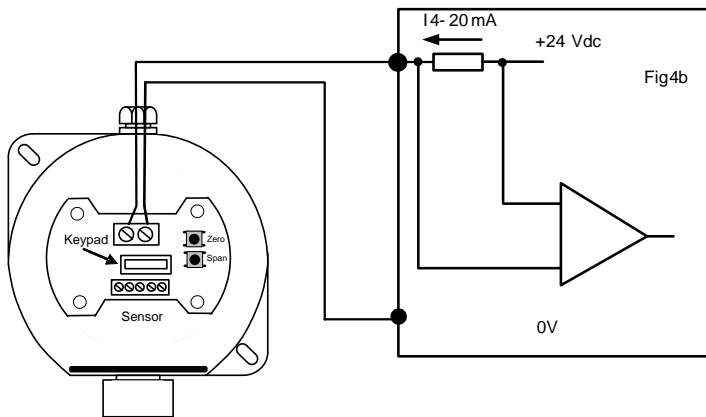

### 4.3.3. FGD4 Infrared current sink

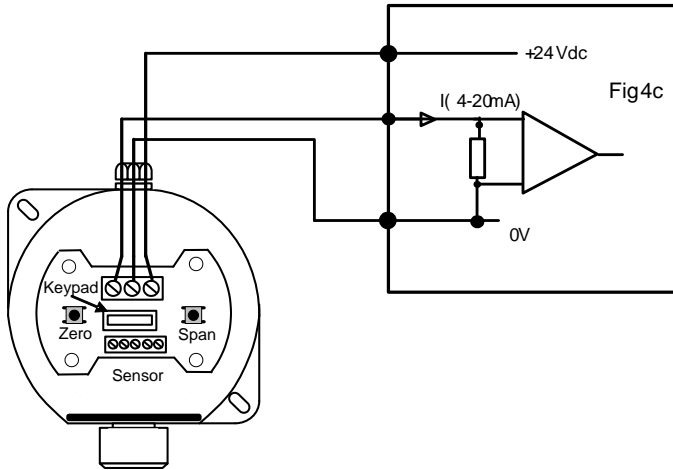

### 4.3.4. FGD4 Infrared current source

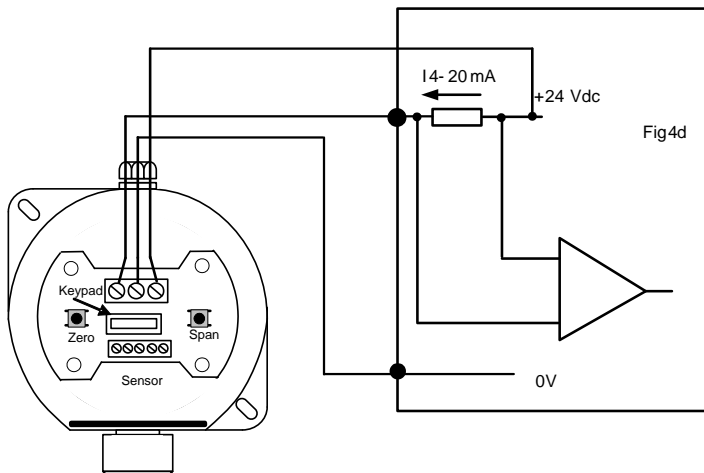

# STATUS SCIENTIFIC CONTROLS

Installation, Commissioning & Routine Gas Testing  
FGD4 Gas Detector



## 5. COMMISSIONING

Following completion of the installation:-

Replace the cover, taking care not to trap the wiring and fix with the 4 allen screws, do not over tighten.

### 5.1. Applying power

Once the installation is complete and the covers are secure then power can be applied. The power source should be between 12 and 24 volts dc.

## 6. INITIAL GAS TESTING

FGD4 units are factory calibrated as detailed on the calibration certificate supplied with the instrument. However, it is always advisable after installation to confirm that the instrument reads zero with no gas present and responds accurately when presented with an appropriate concentration of the target gas.

The FGD4 sensor should be allowed to stabilise for the period specified on the associated calibration certificate before attempting to check the zero setting and gas response.

### 6.1. Zero gas

With no gas present check that the associated control panel display reads zero.

- a) If the instrument reads zero then no adjustment is required and gas response testing may now be carried out as described in Section 6.2.
- b) If the instrument does not read zero then adjustment of the zero setting is required as described in Section 8.1.1. - Sensor Zero.
- c) If the analogue signal is connected to an associated control panel, confirm that when the FGD4 display reads zero, the control panel display also reads zero or, adjust as necessary in accordance with the control panel manufacturers' instructions.

*\* Note – If there is the possibility of a background gas being present then zeroing of the detector should be carried out using a test gas cylinder of air in nitrogen.*

# STATUS SCIENTIFIC CONTROLS

Installation, Commissioning & Routine Gas Testing  
FGD4 Gas Detector



Figure 7 – Arrangement for Application of a Certified Test Gas

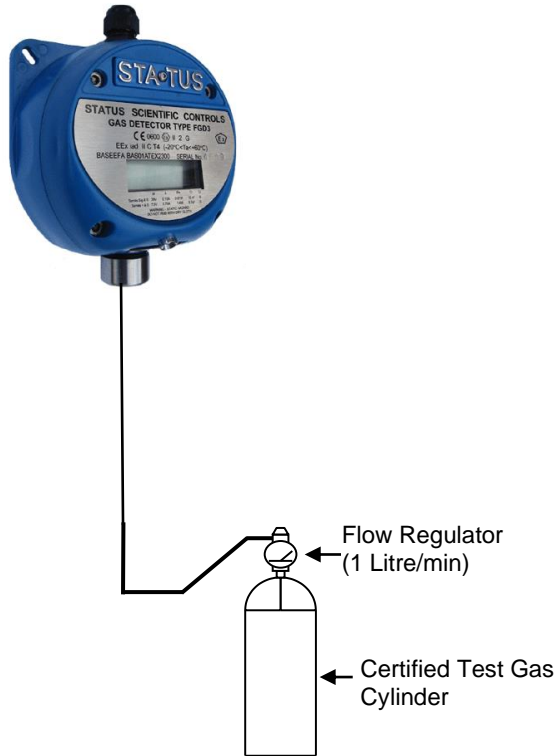

## 6.2. Test gas

Figure 7 shows a typical arrangement for the application of a certified test gas.

The purpose of the test gas response check is to confirm that that the reading on the instrument corresponds with the test gas concentration.

- a) If the associated control panel reads correctly then no adjustment is required.
- b) If the above checks are satisfactory then the installation is now complete.
- c) If the instrument does not read correctly then adjustment of the sensor span setting is required as described in Section 8.1.2. - Sensor Span.

### 6.2.1. Gas connection points

Certified test gas is applied directly to the FGD4 via the appropriate sampling/calibration adaptor.

### 6.2.2. Sampling time

Apply the test gas and allow a sufficient time for the sample to reach the gas detector. The response time will vary according to the length of the sampling tube.

### 6.2.3. Suggested calibration gas levels.

#### Oxygen sensor:

Zero	N <sub>2</sub> .
Span	20.9 %v/v oxygen balance nitrogen.

#### Toxic sensor

Zero	Gas free air, must have oxygen.
Span	50 % of measuring range (FSD).

#### Infrared sensor:

Zero	N <sub>2</sub> .
Span	50 % of measuring range (FSD).

## 7. CALIBRATION

Calibration of the sensor can be carried out by using the buttons on the circuit board as seen in Fig1 and Fig 2.

These buttons only work when the FGD4 Infrared has been powered for a minimum of 10 minutes.

### 7.1. Sensor Zero

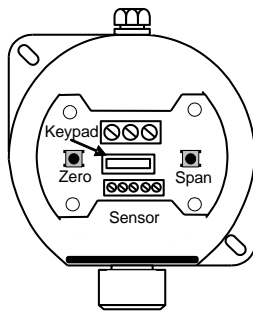

Infrared

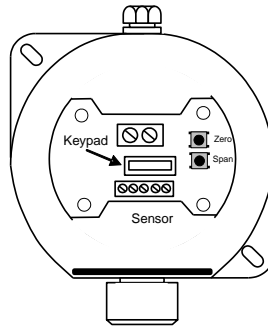

Oxygen / Toxic

Ensure the sensor is in a zero-gas environment.

**Note:** Where a purging gas has to be applied, use a flow rate of between 300 and 1000 cc/min. Allow sufficient time for the sensor to respond.

Press the Zero button  zero and hold for a minimum of 5 seconds to zero the sensor.



# STATUS SCIENTIFIC CONTROLS

Installation, Commissioning & Routine Gas Testing  
FGD4 Gas Detector



## 7.2. Sensor Span

Always zero the sensor prior to performing a span operation.

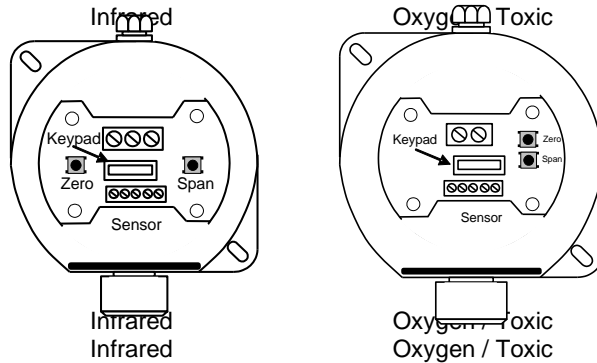

Apply a known concentration of gas (applicable to sensor type) at a flow rate of between 300 and 1000 cc/min. Allow time for the sensor to respond.

Press the Span button  and hold for a minimum of 5 seconds to span the sensor.

Turn off and disconnect the calibration gas.

**Note:** The calibration gas level must match with the level stored in the instrument. If the gas level is does not match then the keypad must be used to set the correct gas level.

# STATUS SCIENTIFIC CONTROLS

Installation, Commissioning & Routine Gas Testing  
FGD4 Gas Detector



## 7.3. Calibration / Configuration Keypad

The FGD4 sensor can be calibrated via a purpose designed keypad. The keypad allows the user to carry out the following:

- 1) calibrate the sensor.
- 2) calibrate the 4 to 20 mA loop.
- 3) View the current gas level.
- 4) View the sensor raw data for diagnostic purposes.

Connect the keypad into the FGD4 as shown below:



The display will give the following messages:

SSCL	Company
----	
88:88	Segment test
SSCL	Manufacturer
1.0.3	Firmware version
----	
0.0	Gas reading

**Note:** if the display is continually showing - - - - then the instrument is not communicating with the keypad.

# STATUS SCIENTIFIC CONTROLS

Installation, Commissioning & Routine Gas Testing  
FGD4 Gas Detector



The menu system featured within the keypad calibration unit allows all calibration and configuration activities to be performed.

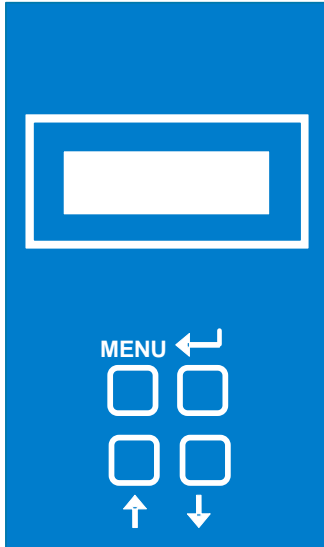

The keypad has the following functionality:

	Button	Function	Alternate Function
MENU	MENU	Open / Close Menu	Password
↑	UP	Next / Increase	1
↓	DOWN	Previous / Decrease	2
↵	ENTER	Accept selection	3

This section of the manual discusses how the available menu options can be accessed, how the associated parameter may be changed via the selected menu option and what effect the change to the parameter has on the operation of the FGD4 Infrared gas detector.

**Note:** It is important that the FGD4 is correctly configured for the sensor in use, prior to performing any feature available in the menu system.

## 7.4. Menu Mode Selection



The external Calibration / Configuration Keypad is used in its simplest form to calibrate the sensor for zero or gas drift.

It may also be used to configure the FGD4.

The following features are available via the Calibration / Configuration Keypad menu system: -

Menu Option	Notes
E : 1 – Sensor Zero	
E : 2 – Sensor Span	
E : 3 – Sensor FSD	
E : 4 – Output Zero (4mA)	
E : 5 – Output Span (20mA)	
E : 8 – Sensor restore	Oxygen / Toxic sensor
E : 9 – Diagnostics	
E : 17 – Sensor Gain	Toxic sensor
E : 19 – Positive zero suppression	Toxic sensor
E : 20 – Negative zero suppression	Toxic sensor
E : 25 – Zero temperature compensation +ve	Toxic sensor
E : 34 – Span temperature compensation +ve	Toxic sensor
E : 35 – Span temperature compensation -ve	Toxic sensor
E : 36 – Zero temperature compensation -ve	Toxic sensor
E : 77 – Firmware version	

The menu options are selected as follows:

- Press the MENU button, **E: 1** appears on the display.
- Press  or  until the required menu option is displayed, see following options.
- Press  to select the menu option.
- To exit the menu press MENU.

*While the instrument is in menu mode – any data displayed on the screen will alternate between the menu number and the reading.*

## 7.4.1. E : 1 – Sensor Zero







Refer to section 8.1.1. for sensor calibration details.

## 7.4.2. E : 2 – Sensor Span

Refer to section 8.1.2. for sensor calibration details.

## 7.4.3. E : 3 – Sensor Fsd

This Feature sets the FSD of the instrument. It must be matched to the sensor.

- Press MENU to open the menu system.
- Using the  or  buttons, select menu option: **E:3**
- Press .
- Using the  or  buttons, change the display to the required setting.
- Press  to store the new value.

Note: Pressing the MENU button rather than the  button exits without any change.

- Press MENU to close the menu system.

## 7.4.4. E : 4 – Output Zero (4mA)

Refer to section 8.2.1. for output calibration details.

## 7.4.5. E : 5 – Output Span (20mA)

Refer to section 8.2.2. for output calibration details.

# STATUS SCIENTIFIC CONTROLS

Installation, Commissioning & Routine Gas Testing  
FGD4 Gas Detector



## 7.4.6. E : 8 – Factory restore

The FGD4 can be restored to the default factory settings.

- Press MENU to open the menu system.
- The sensor type will be displayed.
- Press  to store the new value.

Note: Pressing the MENU button rather than the  button exits without any change.



- Press MENU to close the menu system.

**Note:** This option will restore the sensor to the factory default values. The user must set all parameters before using the unit

## 7.4.7. E : 9 – Engineer diagnostics

This feature is a view-only feature. No configuration changes are possible from within this menu.

The information is for use of Status Scientific Controls personnel.

- From the menu system select menu option: **E: 9** and press .
- Using the  or  buttons, display the required setting. The displayed values are as follows:

E : 90	Reading
E : 91	Current sensor temperature °C
E : 92	Sensor AtoD counts
E : 96	Status flags

# STATUS SCIENTIFIC CONTROLS

Installation, Commissioning & Routine Gas Testing  
FGD4 Gas Detector



## 7.4.8. E : 17 – Sensor gain

This feature is used to set up the gain of the electronics to match the range and sensor type. The range is 0 to 31, where 0 is the lowest gain and 31 is the highest gain.

The gain setting should be kept as low as possible. The gain settings are based on the first stage having a gain of 61.6 (2000 / 33).





Typical settings:

Sensor Type	Max output (nA/ppm)	Make	Range	Resolution (display)	Units	Gain
H <sub>2</sub> S	180	Ind. Sci.	0-50	0.05	ppm	10
H <sub>2</sub> S	180	Ind. Sci.	0-100	0.1	ppm	6
H <sub>2</sub> S	180	Ind. Sci.	0-200	0.5	ppm	2
H <sub>2</sub> S	180	Ind. Sci.	0-500	1	ppm	0
H <sub>2</sub> S(L)	450	Surecell	0-50	0.05	ppm	4
H <sub>2</sub> S(L)	450	Surecell	0-100	0.1	ppm	2
H <sub>2</sub> S(L)	450	Surecell	0-300	0.5	ppm	0
H <sub>2</sub> S(4HS)	850	City Tech	0-50	0.05	ppm	2
H <sub>2</sub> S(4HS)	850	City Tech	0-250	0.1	ppm	0
CO	90	Ind. Sci.	0-200	0.2	ppm	6
CO	90	Ind. Sci.	0-500	0.5	ppm	2
CO	90	Ind. Sci.	0-1000	1	ppm	0
CO(M)	85	Surecell	0-200	0.2	ppm	6
CO(M)	85	Surecell	0-500	0.5	ppm	2
CO(M)	85	Surecell	0-1000	1	ppm	0
CO(4CF)	85	City Tech	0-200	0.2	ppm	6
CO(4CF)	85	City Tech	0-500	0.5	ppm	2
CO(4CF)	85	City Tech	0-1000	1	ppm	0
NH <sub>3</sub> (100SE)	160	Sensoric	0-100	0.1	ppm	6
NH <sub>3</sub> (1000SE)	12	Sensoric	0-1000	1	ppm	10
SO <sub>2</sub> (4S)	600	City Tech	0-20	0.02	ppm	15

**Note:** NH<sub>3</sub> Sensors can have a T<sub>90</sub> of several minutes when protected by a sinter and should not be used in time sensitive applications. Low levels may not be detected.

## 7.4.9. E : 19 – Positive Zero Suppression

This option is used to allow the user to suppress small amounts of positive sensor zero drift. The setting can be set between 0 and 10% of the sensor range as set by the FSD value.







- Press MENU to open the menu system.
- Using the  or  buttons, select menu option: **E:19**
- Press .
- Using the  or  buttons, set the required zero suppression value.
- Press ENTER to store the new value.

Note: Pressing the MENU button rather than the  button exits without any change.

- Press MENU to close the menu system.

## 7.4.10. E : 20 – Negative Zero Suppression

This option is used to allow the user to suppress small amounts of negative sensor zero drift. The setting can be set between 0 and -10% of the sensor range as set by the FSD value.

- Press MENU to open the menu system.
- Using the  or  buttons, select menu option: **E:20**
- Press .
- Using the  or  buttons, set the required zero suppression value.
- Press  to store the new value.

Note: Pressing the MENU button rather than the  button exits without any change.

- Press MENU to close the menu system.



# STATUS SCIENTIFIC CONTROLS

Installation, Commissioning & Routine Gas Testing  
FGD4 Gas Detector



## **7.4.11. E : 25 – Positive Zero Temperature Compensation**

This option has no effect on the sensor version 1.0.3

## **7.4.12. E : 34 – Positive Span Temperature Compensation**

This option has no effect on the sensor version 1.0.3

## **7.4.13. E : 35 – Negative Span Temperature Compensation**

This option has no effect on the sensor version 1.0.3

## **7.4.14. E : 36 – Positive Zero Temperature Compensation**

This option has no effect on the sensor version 1.0.3.

## **7.4.15. E : 77 – Firmware Version**

The FGD4 Firmware version is displayed.

- Press MENU to close the menu system.



## 8. CALIBRATION

### 8.1. Sensor Calibration

This feature allows the sensor to be calibrated. Ensure that the correct sensor type is selected in the configuration prior to calibration. Refer to section 7.4. for details of the menu system operation.





Note: if the password is in operation then the user will be prompted with PASS when ever the menu key is pressed. Pressing the MENU key again will result in the restricted user access, i.e. only the zero and span options will be available. Entering the correct password will give access to the full menu facility.

#### 8.1.1. Sensor Zero

- From the menu system select menu option: **E: 1** and press .
- Ensure the sensor is in a zero-gas environment.  
**Note: Where a purging gas has to be applied, use a flow rate of between 300 and 1000cc/min. Allow sufficient time for the sensor to respond.**
- Press  to zero the sensor, '---' will be displayed to confirm the sensor zero has been performed.  
**Note: Pressing MENU rather than  exits the zero feature without performing the calibration.**
- Press MENU to close the menu system.  
**Note: The ZERO factor will be displayed momentarily on exit.**

## 8.1.2. Sensor Span

Always zero the sensor prior to performing a span operation.

- From the menu system select menu option: **E: 2** and press .
- Apply a known concentration of gas (applicable to sensor type) at a flow rate of between 500 and 1000cc/min. Allow time for the sensor to respond.
- Using the  and  buttons, set the reading to that of the calibration gas level.
- Press  to span the sensor, '----' will be displayed to confirm the sensor span has been performed.

**Note: pressing MENU rather than ENTER exits the span feature without performing the calibration.**

Wait until the reading is stable, if necessary press  again to span the sensor.

- Press MENU to close the menu system.
- **Note: the SPAN factor will be displayed momentarily on exit.**
- Turn off and disconnect the calibration gas.

## 8.2. Analogue Output Calibration

The analogue output is that of a current source. In order to calibrate the output it is necessary to monitor the output signal. This can be performed in one of two ways:

### Current measurement:

Connect an ammeter (or multimeter set to measure current in the mA range) in series with the analogue output.



Advantage: Direct measurement of output.

Disadvantage: The analogue output has to be disconnected to allow the connection of the meter.

### Voltage measurement:



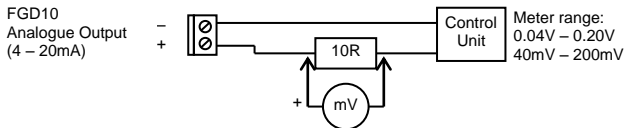

Permanently connect a 10R resistor in series with the analogue output. When calibration is required, connect a voltmeter (or multimeter set to measure voltage in the mV range) across the 10R resistor.



Advantage: No need to disturb wiring between FGD4 and control unit.

Disadvantage: Measurement accuracy dependent upon resistor tolerance.

## 8.2.1. Analogue Output Zero





- Monitor the current sourced from the analogue output of the FGD4 using a suitable method.
- From the menu system select menu option: **E: 4** and press .
- Using the  and  buttons; adjust the output to the required level (4mA or 40mV).
- Press .

Note: Pressing MENU rather than  exits the zero feature without performing the calibration.

- Press MENU to close the menu system.

## 8.2.2. Analogue Output Span

Always zero the analogue output prior to performing a span operation.

- From the menu system select menu option: **E: 5** and press  (button 4).
- Using the  and  buttons; adjust the output to the required level.
- Press .

Note: Pressing MENU rather than  exits the span feature without performing the calibration.

- Press MENU to close the menu system.

## 9. ROUTINE GAS TESTING

Refer to Figure 7, which shows the arrangement for applying the test gas to the FGD4.

1. Before application of the test gas, check that the associated control panel reads zero with no known gas present in the atmosphere. If necessary, carry out adjustment of the zero setting as described in section Sensor Zero.
2. Apply the test gas and allow a sufficient time for the sample to reach the gas detector. The response time will vary according to the length of the sampling tube.
3. If necessary, carry out adjustment of the span setting as described in section 8.1.2. .

Carrying out the above procedure, and comparing the results with previous readings, will confirm that the FGD4 is functioning correctly, both physically and electrically.

The period between carrying out routine gas testing shall be in accordance with the customer's specification.

# STATUS SCIENTIFIC CONTROLS

Installation, Commissioning & Routine Gas Testing  
FGD4 Gas Detector



## 10. FUSES

A 340 mA polyfuse is located within the FGD4. It will automatically reset when normal conditions return.

## 11. SPECIFICATION

<b>Materials</b>	: Instrument Body – injection moulded polycarbonate
<b>Cable entries</b>	: 1 x 20mm
<b>Weights</b>	: FGD4 (excluding weather guard) – 0.5Kg Weather guard – 200 grams
<b>Sensor type</b>	: Electrochemical or Infrared
<b>Input voltage</b>	: 8 to 24 volts dc
<b>Input power</b>	: 5 Watts maximum
<b>Internal fuse</b>	: 340mA 'Nanofuse'
<b>Analogue output</b>	: 4 to 20mA (10 bit resolution)
<b>Comms output</b>	: Communications with hand-held calibration keypad at 38400 baud (3V logic)
<b>Measurement range</b>	: Depends upon sensor type
<b>Response time</b>	: Typically $T_{90} < 40$ sec, depends upon sensor type
<b>IP rating</b>	: Enclosure IP68, Sensor IP65
<b>Display / Keypad</b>	: External via internal connector
<b>Operating temperature</b>	: - 20 to +60 °C
<b>Humidity range</b>	: 0 to 95% RH non-condensing
<b>Operating pressure</b>	: Atmospheric + or - 10%

## 12. DIMENSIONS & MOUNTING DETAILS

The diagram below shows the mounting centres for the FGD Detector Head Enclosure.

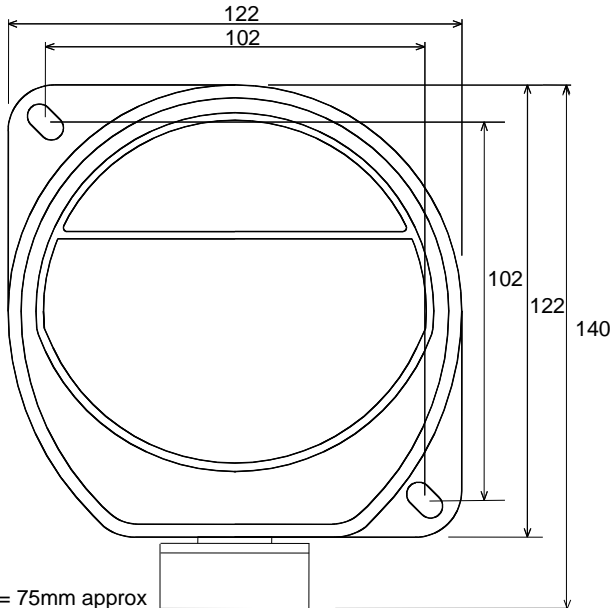

### Note:

The front panel/lid of the detector head opens to allow access to the screw terminals situated inside. Sufficient space should be allowed around the mounting position so that this action is not restricted.

### Fixings Required:

2 off M6 Fasteners  
(Rawl Bolts or similar dependent on mounting wall construction)



# STATUS SCIENTIFIC CONTROLS

Installation, Commissioning & Routine Gas Testing

FGD4 Gas Detector



## CUSTOMER NOTES