



CLF-5

Liquid Particle Filter Series CLF®

Version CLF-5, CLF-5/W for the separation of aerosols from gases

Special Features

- **High retention rate of 99.9999 % for particles > 0.1 µm**
- **Also with integrated hydrophobic diaphragm for analyzer protection**
- **Condition of filter element visible from outside**
- **Easy change of filter element**
- **Wall-mounting**

Application

The M&C liquid particle filters CLF-5 and CLF-5/W are suitable for the separation of all types of fine liquid particles and are recommended for sample gases with an acid dew point above 100 °C [212 °F], for example for flue gas measurements of heavy oil or hard coal combustion plants.

The filter separates aerosols (finest liquid droplets) which still have passed the sample gas cooler. After sample conditioning, the CLF-5 is best positioned directly in front of the flow meter of the analyzer.

To increase system reliability, the CLF-5/W version is equipped with an integrated hydrophobic protective membrane.

liquids. The hydrophobic protective membrane integrated in the filter element holder prevents the liquid from breaking through to the filter outlet in the event of a malfunction.

Due to the glass filter body, the condition of the filter is immediately visible from the outside without opening the filter assembly.

The GL 25 connection enables automatic emptying of the liquid by means of an optional SR25.2.W external peristaltic pump.

No tools are required for element replacement. The optimum positioning of the O-ring always ensures a secure sealing between the filter body and the filter head. Filter inlet and outlet can be rotated 180° on the wall mounting, allowing flexible adaptation to local conditions during installation.

Description

The filter element of the M&C liquid particle filter CLF-5 has a two-layer construction and the flow direction is from the inside to the outside. The inner, very fine layer binds the fine liquid particles suspended in the gas and forwards them with the gas flow to the outer, coarser layer. On their way through the filter element, the very fine liquid particles accumulate to form droplets. The vertical flow direction, together with gravity, supports the dripping of the liquid into the filter glass.

The filter element retains its efficiency even when completely saturated with liquid. Without being contaminated by solid particles, its service life is almost unlimited. The pressed microfibers are joined with PVDF binder to avoid the influence on sample gas. The CLF-5/W version is equipped with a breakthrough stop for water and water-like

Handle with care! Danger of acid burns!

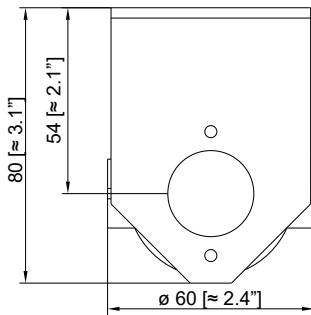
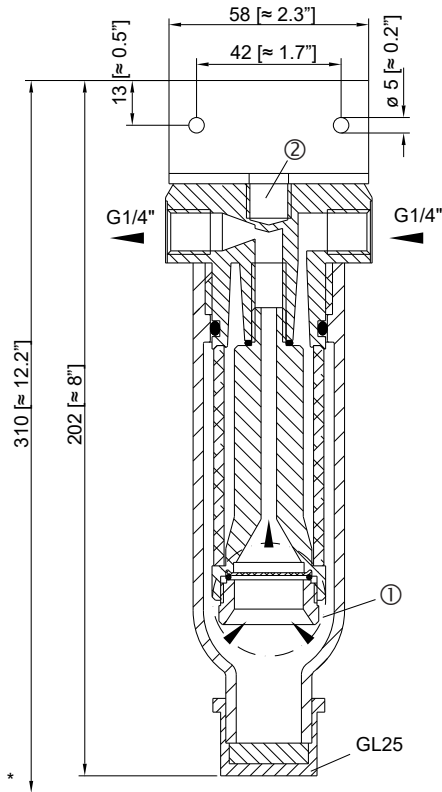

* Dimensions required for dismounting 310 mm [≈ 12.2"]

Dimensions in mm [Inches]

- ① Protective hydrophobic diaphragm unit only with version CLF-5/W.
- ② On request the G 1/4" i thread connection can be used as a second gas outlet through a $\varnothing 5$ mm [≈ $\varnothing 0.2$] bore hole.

Technical Data

Liquid particle filter	CLF-5	CLF-5/W
Part No.	03F3000	03F3005
Option: water stop	None	Yes
Gas flow	Max. 300 NI/h	Max. 200 NI/h
Gas pressure	0.2 to 2 bar abs. ΔP max. 1.0 bar	0.3 to 2 bar abs. ΔP max. 0.5 bar
Differential pressure with a new filter element, with air, 20 °C [68 °F]	3 6 10 mbar 100 200 300	17 35 mbar 100 200
Sample temperature	Max. +80 °C [176 °F]	
Ambient temperature	0 to +60 °C [32 to 140 °F]	
Storage temperature	-25 to +80 °C [-13 to 176 °F]	
Filter element/retention rate	2-layers CLF-5/99.9999 % for particles > 0.1 μ m	
Filter dead volume	70 cm ³	
Volume capacity for liquid	20 ml	
Material of sample contacting parts	PVDF, glass, FKM	PVDF, glass, FKM, PTFE, Polyester
Sample gas-/drain connection	G 1/4" i DIN ISO 228/1/GL 25 cap	
Type of mounting	Wall-mounting	
Weight	Approx. 0.3 kg [≈ 0.7 lb]	

Please note: NI/h and NI/min refer to the German standard DIN 1343 and are based on these standard conditions: 0 °C [32 °F], 1013 mbar.