



CSS

19" Gas Conditioning Unit Series CSS®

Version CSS for max. 150 NI/h
Version CSS-3 for max. 350 NI/h

Special Features

- **Completely pre-installed and ready for operation within 10 minutes**
- **Individually configurable**
- **Self-monitoring and minimum maintenance**
- **Up to 5 calibration gases manually or externally switchable**
- **One or two gas path(s)**
- **Water vapor dew point input up to +80 °C [176 °F]**
- **Outlet dew point adjustable from +2 to +15 °C [35.6 to 59 °F]**
- **Dew point stability ± 0.1 °C [± 0.18 °F]**

Application

With these units, completely pre-installed gas conditioning systems for continuous operation have been created, which can be integrated excellently into analyzer systems. The compact design requires only little space. The conditioning units are ready for operation within a few minutes.

The usual time-consuming procurement of individual components and small parts as well as their assembly have finally become superfluous. Application examples of the CSS and CSS-3 sample gas conditioning systems are flue gas and process gas conditioning. In the event of special problems, such as aerosols, various solvents, explosive gases or installation areas in Ex zones, we can propose further solutions.

In the event of failure, the liquid alarm automatically switches off the gas pump and the inlet solenoid valve.

Great importance was attached to the maintenance-friendly design of the unit. The parts to be maintained are easily accessible via a removable front sub-panel without having to disassemble the entire system.

The CSS or CSS-3 sample gas conditioning units in a 19" rack are available for 230 V or 115 V AC mains voltage.

The CSS-3/C sample gas conditioning unit provides the possibility of directly injecting calibration gas to the sample gas probe, e.g. SP2000-H/R, for the calibration of the complete system.

Description

The M&C gas conditioning units CSS and CSS-3 are compact, low-maintenance, self-monitoring and completely equipped units (see table page 3) suitable for standard applications.

Toggle switches for the different functions are located on the front panel:

EXTERNAL-INTERNAL	→	ON
PUMP OFF	↔	PUMP ON
MEASURE	↔	CHECK
SAMPLE GAS	↔	TEST GAS
ZERO GAS	↔	SPAN GAS

With an optional 4-position rotary switch, it is possible to select more than one calibration gas. Active functions are indicated by LEDs.

All functions of the CSS or CSS-3 can be controlled externally via potential-free contacts, e.g. an automatic calibration device of an analyzer.

The sample gas pump is integrated in an automatic interlock circuit and is only switched on when the electric gas cooler reaches an operating temperature of < +8 °C [45 °F].

Functional Diagramm

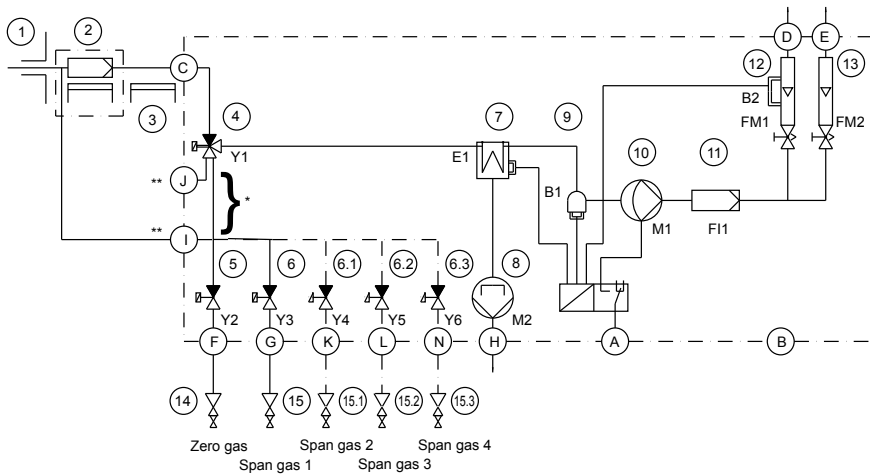

- 1 Gas sample probe SP2000-H
- 2 Heated filter
- 3 Heated sample line 4M.
- 4 3-way solenoid valve 124C3
- 5 2-way solenoid valve 2011
- 6 2-way solenoid valve 2011
- 7 Gas cooler ECP1000/3000
- 8 Peristaltic pump SR25.1
- 9 Liquid sensor LA1
- 10 Diaphragm pump N3/9 KPE
- 11 Gas filter PPF0,1
- 12 Flow meter with alarm FM40 / FA1
- 13 Flow meter FM40
- 14 Zero gas
- 15 Span gas, standard 1 x, optional + 3 x
- A Status alarm/remote control of valves
- B Power supply
- C Sample gas INLET
- D Sample gas OUT 1 with flow alarm
- E Sample gas OUT 2
- F Zero gas IN
- G Span gas IN
- H Condensate OUT
- I Test gas to the probe **only in CSS-3/C
- J Vent **only in CSS-3/C
- K Span gas 3 - IN option
- L Span gas 3 - IN option
- N Span gas 4 - IN option

* No tubing for version CSS-3/C
 **Only in CSS-3/C

Dimensions

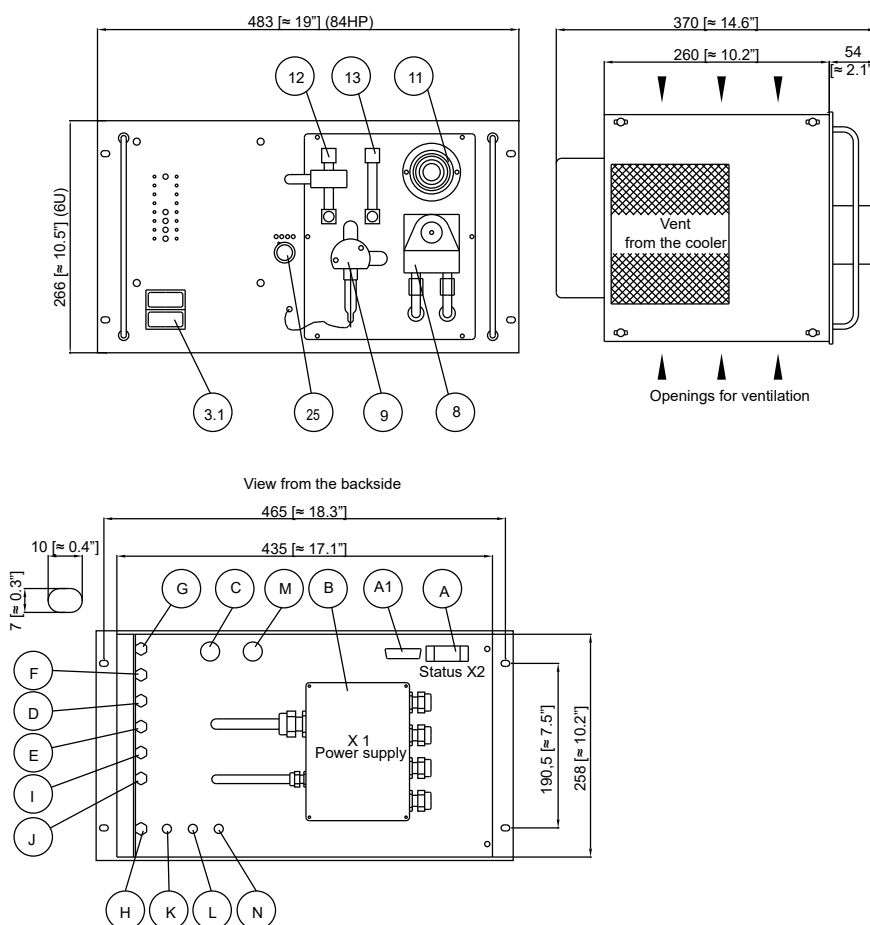

- 3.1 Temperature controller 703 option
- 8 Peristaltic pump SR25.1
- 9 Liquid alarm sensor LA1
- 11 Fine filter PPF 0,1
- 12 Flow meter with alarm FM40/FA1
- 13 Flow meter FM40
- A Status alarm/remote control of valves
- A1 Reserve
- B Power supply
- C Sample gas INLET
- D Sample gas OUT 1 with flow alarm
- E Sample gas OUT 2
- F Zero gas IN
- G Span gas IN
- H Condensate OUT
- I Test gas to the probe **only in CSS-3/C
- J Vent **only in CSS-3/C
- K Span gas 2 - IN option
- L Span gas 3 - IN option
- M Reserve
- N Span gas 4 - IN option

Dimensions in mm [Inches]

19" Gas Conditioning System Series CSS*	Version CSS	Version CSS-3
Inlets and max. gas flow**	1 x 140 NI/h	1 x 350 NI/h
Outlets incl. flow meters	2 x 70 NI/h	2 x 250 NI/h
Gas pressure	0.7 to 1.2 bar abs.	
Sample gas inlet temperature**	Max. 150 °C [302 °F]	
Sample gas inlet dew point**	Max. 80 °C [176 °F]	
Sample gas outlet dew point	Range of adjustment: +2 to +15 °C [36 to 59 °F], factory setting: +5 °C [41 °F]	
Dew point stability	At constant conditions < ±0.1 °C [< ±0.18 °F]	
Ambient temperature**	+5 to +40 °C [41 to 104 °F]	+5 to +45 °C [41 to 113 °F]
Total cooling capacity at +25 °C [77 °F] ambient temperature	Max. 50 kJ/h	Max. 90 kJ/h
Storage temperature	-25 to +65 °C [-13 to 149 °F]	
Relative humidity	< 80 %	
Ready for work	Approx. 10 min	
Gas filter	Glass fiber, porosity 0.1 µm	
Housing	19" rack mounting 6 U, depth 350 mm [≈ 13.8"], color RAL 7032	
Degree of protection	IP20 EN 60529	
Tube connections	G 1/4" female (standard), DIN ISO 228/1*	
Power supply	230 V, 48-62 Hz, 150 VA or 115 V, 48-62 Hz, 150 VA	230 V, 48-62 Hz, 250 VA or 115 V, 48-62 Hz, 250 VA
Electrical equipment standard	EN 61010	
Electrical connections	Power terminals max 4 mm ² , 4 x PG 13.5 Alarm/control signals 15-pin Sub-D connector	
Status signal	Cooler temperature, liquid alarm, flow alarm	
Status alarm contact, contact rating	Potential-free changeover contact, max. 24 V, 1 A	
Test gas inlets	2 solenoid valves, actuated manually or via external switch (standard, optional +3 pieces)	
Material of sample-contacting parts	PVDF, glass, FKM, Novopren, PTFE	
Weight	Approx. 15 kg [≈ 33.1 lbs]	Approx. 16.5 kg [≈ 36.4 lbs]
Option:		
Electronic PID temperature controller 703 for heated sample lines	Front-panel mounting, range 0 to 200 °C [32 to 392 °F], sensor PT 100 or Fe-CuNi, controlling outlet with a solid state relays 10 A***, alarm output integrated into the CSS status alarm, parameter freely configurable	

* The dimensions and designation of the screw-in threads correspond to the respective applicable standard. The tolerances of the thread standards are matched to metal threads and cannot be applied to plastic threads.

** Maximum values in technical data must be rated in consideration of the total cooling capacity at 25 °C [77 °F] ambient temperature and 5 °C [41 °F] outlet dew point.

*** Standard for max. 20 m heated sample line at 110 W/m.

Please note: NI/h and NI/min refer to the German standard DIN 1343 and are based on these standard conditions: 0 °C [32 °F], 1013 mbar.

Equipment	Conditioning Unit CSS	Conditioning Unit CSS-3
Sample gas inlet	1	
Sample gas outlets	2	
Flow meter with needle valve	FM 40 70 NI/h air	FM 40 250 NI/h air
Electric gas cooler	ECP 1000-G90° for 150 NI/h	ECP 3000-G90° for 350 NI/h
Diaphragm pump	N3KPE	N9KPE
Peristaltic pump	SR 25.1	
Ultra-fine filter	FPF 0,1 GF with glass-fiber filter element 0.1 µm	
External or manual switching from measuring to testing with zero or span gas	1 x 3/2-way solenoid valve 124C3 and 2 x 2/2-way solenoid valves 2011, optional +3 pcs.	
Tubing and connectors	PTFE, PVDF	
Status alarm with optical display	For cooler temperature, flow failure and liquid alarm	
Optional	Electronic temperature controller for heated sample line	

Part No.	
03G1000(a)	19" gas conditioning unit CSS for 140 NI/h (230 V: Part No. 03G1000, 115 V: Part No. 03G1000a)
03G3000(a)	19" gas conditioning unit CSS-3 for 350 NI/h (230 V: Part No. 03G3000, 115 V: Part No. 03G3000a)
03G3100(a)	19" gas conditioning unit CSS-3/C for 350 NI/h and test gas to sample probe (230 V: Part No. 03G3100, 115 V: Part No. 03G3100a)
	Option
03G9020(a)	Extra charge for CSS, CSS-3 with 3 calibration valves (230 V: Part No. 03G9020, 115 V: Part No. 03G9020a)
03G9025(a)	Extra charge for CSS, CSS-3 with 4 calibration valves (230 V: Part No. 03G9025, 115 V: Part No. 03G9025a)
03G9030(a)	Extra charge for CSS, CSS-3 with 5 calibration valves (230 V: Part No. 03G9030, 115 V: Part No. 03G9030a)
03G9000	Extra charge for integrated electronic temperature controller 703 for heated sample line

Special versions upon request.