



NS KP18

Diaphragm Pump Series N®

Versions N3/5/9 KPE and N3/5/9 KP18

Special Features

- Corrosion-resistant
- 100 % lubricant-free
- Gas-tight
- Maintenance-free
- 3 types with different capacities
- Compact design

Application

The compact diaphragm pumps type N3/5/9 are suitable for sampling air, gases and vapours in a temperature range from +5 to +40 °C [41 to 104 °F]. Their performance characteristics and design are specially geared to the problems encountered in analytical technology.

Description

The diaphragm pumps of the N3/5/9 series deliver gases 100 % lubricant-free. They operate gas-tight and maintenance-free. The three performance variants N3/N5/N9 are available as built-in versions KPE without protective housing or as KP18 with protective housing. The sound emission of the pumps without housing is already below 55 db(A). The compact design of the shaded-pole motor makes it possible to manufacture a space-saving pump with low weight. The drive motors have two motor windings for universal mains operation with 115 V or 230 V.

All pump parts that come into contact with the sample are made of high-quality corrosion-resistant materials.

For trouble-free operation, the permissible operating overpressure of 0.5 bar must be observed in the case of the N9 variant. For this reason, the gas flow should be reduced or regulated on the suction side by means of a needle valve or by means of an overpressure valve or bypass on the pressure side.

Dimensions



Diaphragm pump N3 KPE and N5 KPE built-in version

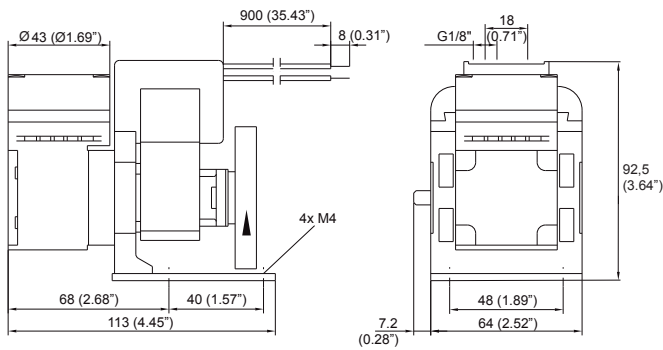

Diaphragm pump N9 KPE built-in version

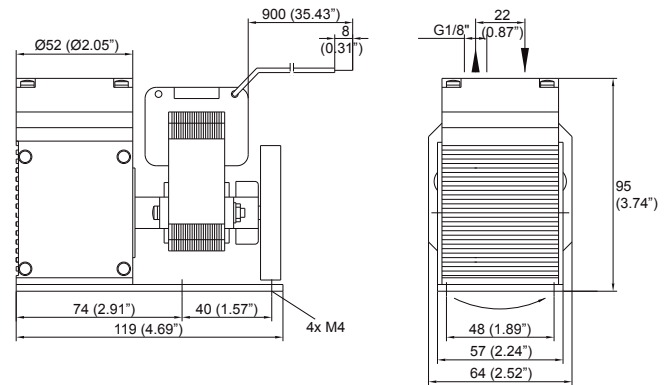

Diaphragm pump N3 KP18 and N5 KP18 with housing

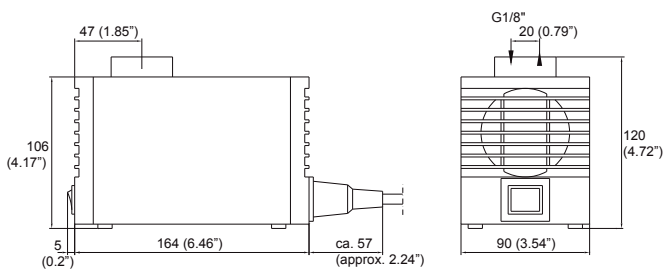

Diaphragm pump N9 KP18 with housing

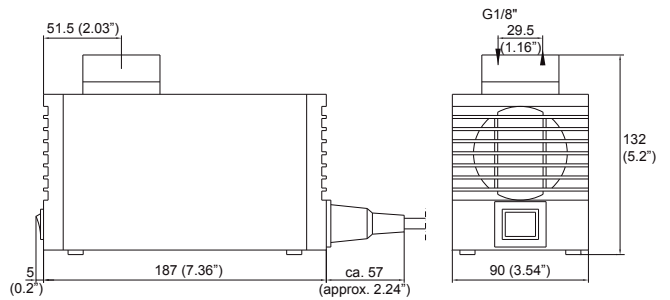

Dimensions in mm (inch)

Pump Capacities

N3 KPE/KP18 and N5 KPE/KP18

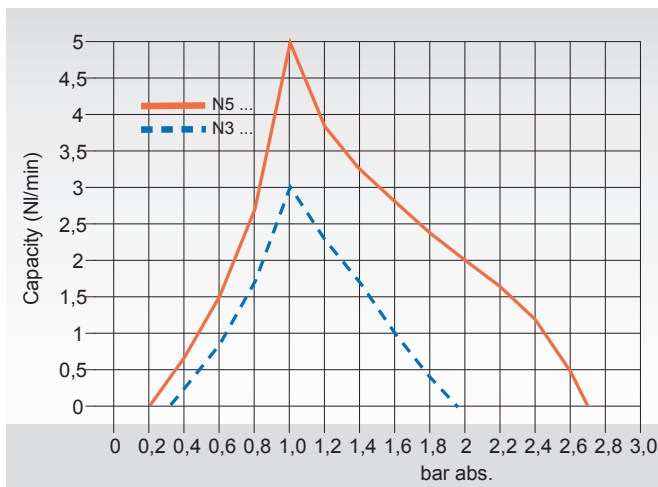

N9 KPE/KP18

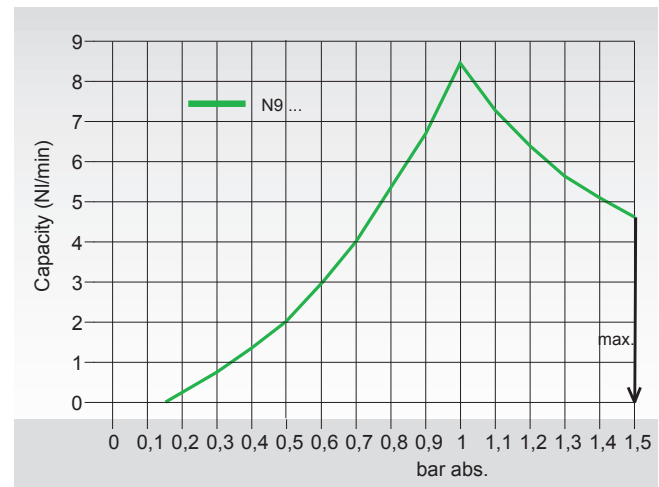

Operating pressure max. 1.5 bar abs.!

Pump Series N	N3 KPE/N3 KP18	N5 KPE/N5 KP18	N9 KPE/N9 KP18
Part number*	02P3351/02P3006 (a)*	02P3355/02P3007 (a)*	02P3360/02P3008 (a)*
Housing version	No/yes		
Max. capacity at atmospheric pressure	3 NI/min	5 NI/min	8.5 NI/min
Max. operating pressure	0.25 to 1.95 bar abs	0.15 to 2.7 bar abs.	0.15 to 1.5 bar abs.
Sample and ambient temperature	+5 up to +40 °C [41 up to 104 °F]		
Storage temperature	-15 up to +60 °C [5 up to 140 °F]		
Operation mode	Continuous		
Power supply selectable at terminal block via wire jumper	230 V/50 Hz, 0.75 A or 115 V/60 Hz, 1.5 A 60 W		230 V 50 Hz, 0.65 A or 115 V 60 Hz, 1.2 A 60 W
Electrical connection	KPE: Wire 4 x 0.5 mm ² , approx. 900 mm [≈ 35.4"] long KP18: Cold appliance plug with 2 fuses 230 V - 1 A / 115 V - 3.2 A, 2.5 m [≈ 8.2 ft] cable and power switch		
Protector	Thermo switch, double (115 V/230 V)		
Protection	KPE: IP00 EN 60529		
	KP18: IP20 EN 60529		
Weight	KPE: 1.1 kg [≈ 2.4 lbs] KP18: 1.9 kg [≈ 4.2 lbs]		... KPE: 1.3 kg [2.9 lbs] ... KP18: 2.1 kg [4.6 lbs]
Gas connections	G 1/8"i DIN ISO 228/1		
Material of parts in contact with the sample	Pump head: PVDF, diaphragm: PTFE, valves/sealing: Viton®		
Housing material KP18	AL-Mg-Si-0,5/firmness: F25, color RAL 9002 white-grey		

*For diaphragm pumps version (N... KP18) with housing in 115 V, please specify in your order: power 115 V and add an 'a' to the part number.
 Viton® is a registered trademark used by DuPont Performance Elastomers, USA.
 Please note: NI/h and NI/min refer to the German standard DIN 1343 and are based on these standard conditions: 0 °C [32 °F], 1013 mbar.