



Combustible Gas Detector E2630-LEL



Features

- Methane, LPG, Hydrogen, Acetylene
- Accurate and stable measurement
- Wall-mount IP65 protected housing
- Visual and acoustic alarms
- Two output relays for alarm / ventilation control

Specifications

Calibration	Methane, Butane, Propane, Acetylene, Hydrogen
Sensor type	Metal Oxide Semiconductor
Sampling method	Diffusion
Typical detection range	0...100% LEL
Resolution	0,1 %LEL
Response time T90	~60 seconds
Signal update	Every 1 second
Sensor lifetime	> 5 years
Maintenance interval	12 months
Self-diagnostics	Full functionality check at start-up, testing by magnetic switch
Warm-up time	≤ 1 min
Power supply	24 VAC/DC or 90...265 VAC
Power consumption	< 2 VA
Digital interface	UART
Output relays	2 relays with switch-over contact (SPDT), 250 VAC / 30 VDC, 5 A max
Default alarm set-points	Release - LOW - HIGH 7 - 10 - 25% LEL
Alarms	Blinking LED, buzzer 85 dB
Enclosure	Grey ABS plastic, wall mount, protection class IP65
Dimensions	H140 × W145 × D55 mm
Operating conditions	-40...+70 °C <95 %RH, non-condensing pressure 0,9...1,1 atm Non-ATEX rated spaces Normal ambient oxygen level Avoid strong mechanical shock, vibrations or EMI; Avoid exposure to corrosive gases or silicone containing products.

Dimensions

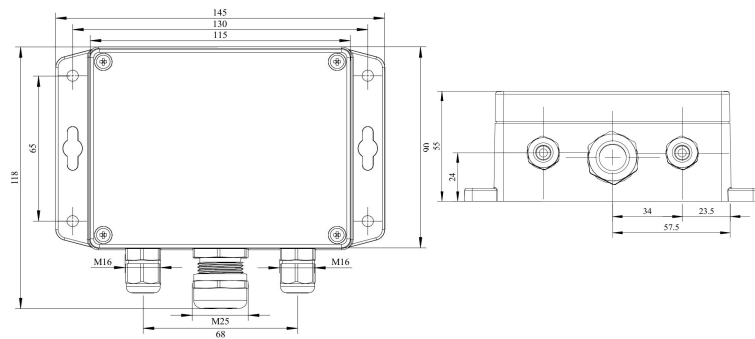

Magnet key

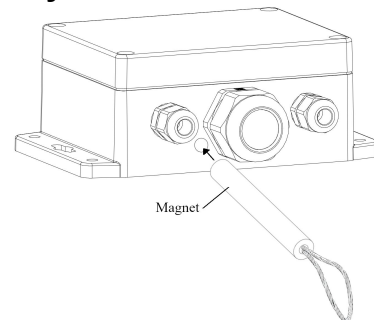

Connection diagram

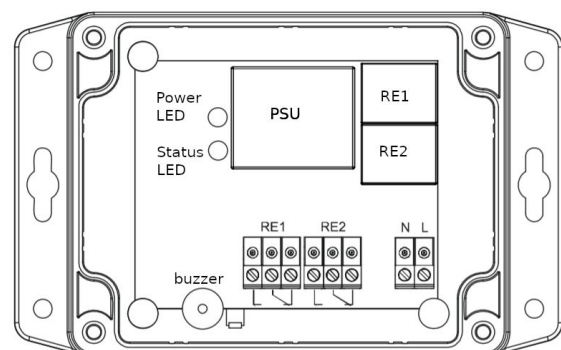

Ask for other versions or custom designed products

