



DESCRIPTION AND APPLICATION

These resistance-type sensors are intended for contact temperature measurements of liquid or gaseous substances. The structure of the sensor's stem enables the sensor to be used for direct measuring of the temperature in ducts and also ensures quick response of the sensor to changes in temperature. The standard operating temperature range is -30 to 130 °C. The sensors can be utilised for any control systems that are compatible with sensing element output signals or output signals quoted in the table of sensing element types.

The sensors are designed to be operated in a chemically non-aggressive environment.

DECLARATION, CERTIFICATES, CALIBRATION

Declaration of Conformity – in accordance with EN ISO/IEC 17050-1 standard as amended for sensors with resistance output.

EC Declaration of Conformity – in accordance with Act No. 22/1997 Coll. as amended for sensors with an output of 4 to 20 mA.

Calibration – we perform standard calibration of resistance temperature sensors in accordance with EN ISO/IEC 17025 standard in the temperature range of the stated type of sensor.



MAXIMUM STREAM VELOCITY OF THE MEASURED MEDIUM - AIR AND WATER VAPOUR / WATER [m.s⁻¹]

Length of the stem	up to 60 mm	> 60 to 100 mm	> 100 to 160 mm	> 160 to 220 mm
Values for diameter of the stem 4 mm	8 / 0.8	6 / 0.6	3.2 / 0.4	1.0 / 0.25

SPECIFICATIONS

BASIC DATA

Sensor type	NK 160	NK 161	NK 162
Type of sensing element	Ni 1000/5000	Ni 1000/6180	Ni 891
Measuring range	-30 to 130 °C (Connection head ambient temperature -30 to 100 °C)		
Maximum measuring DC current	1 mA	1 mA	1 mA

Sensor type	PTK 160	PTK 260	PTK 360	HK 160
Type of sensing element	PT 100/3850	PT 500/3850	PT 1000/3850	thermistor NTC 20 kΩ
Measuring range	-50 to 130 °C (Connection head ambient temperature -30 to 100 °C)			-30 to 130 °C
Maximum measuring DC current	3 mA	1.5 mA	1 mA	10 mW *)

*) maximum power consumption

Sensor type	NK 560	Note
Type of sensing element	Pt 1000/3850	
Output signal	4 to 20 mA	
Measuring ranges	-50 to 50 °C	Connection head ambient temperature -30 to 70 °C
	-30 to 60 °C	
	0 to 35 °C	
	0 to 100 °C	
	0 to 150 °C	
Power supply (V _{CC})	10 to 30 V DC	Recommended value 24 V DC
Maximum voltage ripple V _{CC}	0.5 %	
Load resistance	50(V _{CC} -9) Ω	
Output signal		
- sensing element break	> 24 mA	
Output signal		
- sensing element shorg	< 3.5 mA	

OTHER PARAMETERS

Accuracy class	Ni sensing elements: B class, $\Delta t = \pm (0.4 + 0.007t)$, for $t \geq 0$; $\Delta t = \pm (0.4 + 0.028 t)$, for $t \leq 0$ in °C; Pt sensing elements: B class according to IEC 751, $\Delta t = \pm (0.3 + 0.005 t)$ in °C NTC 20 k Ω : ± 1 °C for the range 0 to 70 °C
Measuring error for NK 560	< 0.6 % of the measuring range, minimum 0.5 °C
Sensor connection	according to the wiring diagram
Standard length of the stem L1	50, 100, 160, 220 mm
Diameter of the stem	4 \pm 0.1 mm
Standard thread	G 1/2"
Nominal pressure of the stem	PN 25
Time response	$\tau_{0.5} < 4$ s (in streaming water at 0.4 m.s ⁻¹)
Recommended wire cross section	0.35 to 1.5 mm ²
Insulation resistance	> 200 M Ω at 500 V DC, 25° \pm 3 °C; humidity < 85 %
Ingress protection	IP 54 according to EN 60 529
Material of the stem	stainless steel 1.4301
Material and type of connection head	aluminium alloy, LIMATHERM MA
Operating conditions	ambient temperature: -30 to 100 °C; -30 to 80 °C with a converter relative humidity: max. 85 % (at the ambient temperature 25 °C) atmospheric pressure: 87 to 107 kPa
Mass	approximately 0.2 kg

WIRING DIAGRAM

With a resistance output

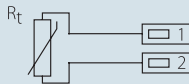

With a converter 4 to 20 mA

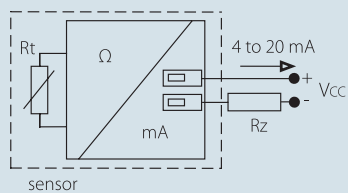

DIMENSIONAL DRAFT

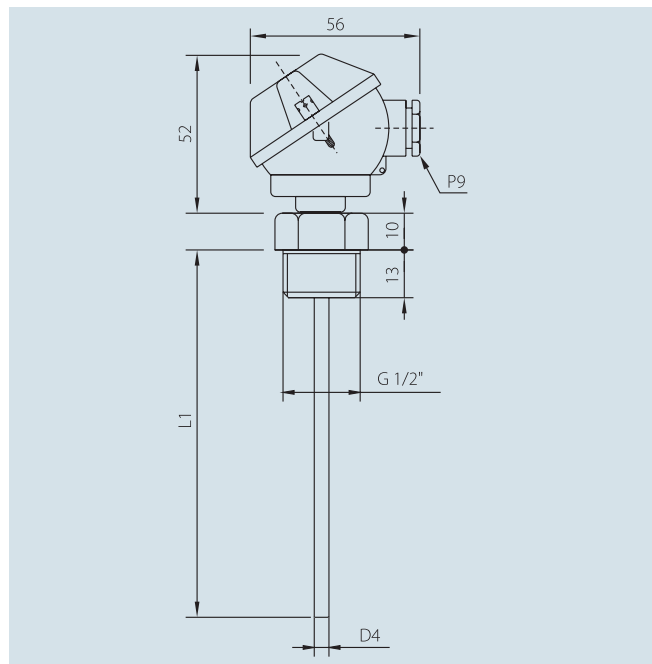

SENSOR INSTALLATION AND SERVICING

Before connecting the supply lead-in cable, position the sensor in the location of temperature measurement, and screw off the lid of the metal connection head. The lead-in cable is connected to the terminals according to the wiring diagram through the loosened grommet. The recommended wire cross section is 0.35 to 1.5 mm², the outer diameter of the circular cross-section cable can range between 4 and 8 mm.

In case the lead-in cable is laid in the vicinity of high voltage conductors or those supplying equipment creating disturbing electromagnetic field (e.g. inductive load equipment), a shielded cable should be used.

To insure the ingress protection value of IP 54 the grommet has to be tightened and the lid has to be screwed on after connecting the lead-in cable. After installing and connecting the sensor to the appropriate evaluating electrical equipment the sensor is ready to use. The sensor does not require any special attendance or maintenance. The device can be operated in any working position, but the grommet must not be directed upwards.

CUSTOMER SPECIFIC MODIFICATIONS

REGARDING TO SENSORS MANUFACTURED IN A STANDARD VERSION THE FOLLOWING PARAMETERS CAN BE MODIFIED:

- A class precision (with the exception of sensor termistor NTC 20 k Ω)
- option of three- or four-wire connection
- variable stem design – L1 length, materials, diameters, option of thread design