

TEMPERATURE SENSORS FOR OUTDOOR USE WITH A CONNECTION METAL HEAD



DESCRIPTION AND APPLICATION

These resistance-type sensors are intended for contact temperature measurement of gaseous substances outdoors or in industrial areas. The standard operating temperature range is -30 to 100 °C. The sensors can be utilised for any control systems that are compatible with sensing element output signals or output signals quoted in the table of sensing element types.

The sensors are designed to be operated in a chemically non-aggressive environment.

ACCESSORIES

- The metal central holder K110.

DECLARATION, CERTIFICATES, CALIBRATION

Declaration of Conformity – in accordance with EN ISO/IEC 17050-1 standard as amended for sensors with resistance output.

EC Declaration of Conformity – in accordance with Act No. 22/1997 Coll. as amended for sensors with an output of 4 to 20 mA.

Calibration – we perform standard calibration of resistance temperature sensors in accordance with EN ISO/IEC 17025 standard in the temperature range of the stated type of sensor.



SPECIFICATIONS

BASIC DATA

Sensor type	NK 110	NK 111	NK 112	NK 310	NK 311
Type of sensing element	Ni 1000/5000	Ni 1000/6180	Ni 891	Ni 10000/5000	Ni 10000/6180
Measuring range	-30 to 100 °C				
Maximum measuring DC current	1 mA	1 mA	1 mA	0.3 mA	0.3 mA

Sensor type	NK 113	PTK 110	PTK 210	PTK 310	HK 110
Type of sensing element	T1 = Ni 2226	PT 100/3850	PT 500/3850	PT 1000/3850	thermistor NTC 20 kΩ
Measuring range	-30 to 100 °C				
Maximum measuring DC current	0.7 mA	3 mA	1.5 mA	1 mA	1 mW *)

*) maximum power consumption

Sensor type	NK 510	Note
Type of sensing element	Pt 1000/3850	
Output signal	4 to 20 mA	
Measuring ranges	-30 to 60 °C	Connection head ambient temperature -30 to 80 °C
	0 to 35 °C	
	0 to 100 °C	
	0 to 150 °C	
Measuring error	< 0,6 % of the range	0.5 °C at least
Power supply (V _{CC})	10 to 30 V DC	Recommended value 24 V DC
Maximum voltage ripple V _{CC}	0.5 %	
Load resistance	50(V _{CC} -9) Ω	
Output signal	> 24 mA	
- sensing element break		
Output signal	< 3.5 mA	
- sensing element short		

OTHER PARAMETERS

Accuracy class	Ni sensing elements: B class, $\Delta t = \pm (0.4 + 0.007t)$, for $t \geq 0$; $\Delta t = \pm (0.4 + 0.028 t)$, for $t \leq 0$ in °C; Pt sensing elements: B class according to IEC 751, $\Delta t = \pm (0.3 + 0.005 t)$ in °C NTC 20 kΩ: ± 1 °C for the range 0 to 70 °C
Sensing element connection	according to the wiring diagram
Standard length of the stem	for resistance output - 25 mm for output 4 to 20 mA - 50 mm
Time response	$\tau_{0.5} < 9$ s (in air streaming at 1 m s ⁻¹)

TEMPERATURE SENSORS FOR OUTDOOR USE WITH A CONNECTION METAL HEAD

Recommended wire cross section	0.35 to 1.5 mm ²
Insulation resistance	> 200 MΩ at 500 V DC, 25° ±3 °C; humidity < 85 %
Ingress protection	IP 54 according to EN 60 529
Material of the stem	stainless steel 1.4301
Type of connection head	LIMATHERM MA
Material of the connection head	aluminium alloy
Operating conditions	ambient temperature: -30 to 100 °C; -30 to 80 °C with a converter
	relative humidity: max. 85 % (at the ambient temperature 25 °C)
	atmospheric pressure: 87 to 107 kPa
Mass	approximately 0.2 kg

WIRING DIAGRAM

With a resistance-type output

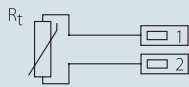

With a converter 4 to 20 mA

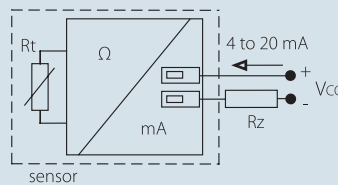

DIMENSIONAL DRAFT

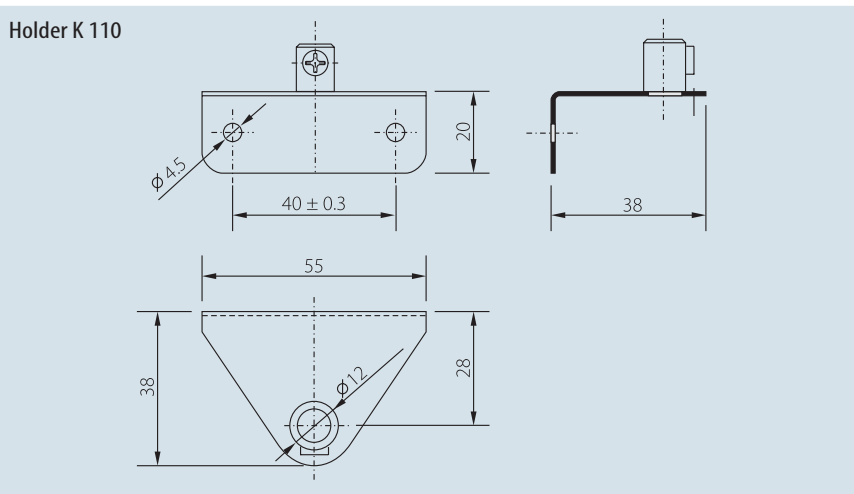
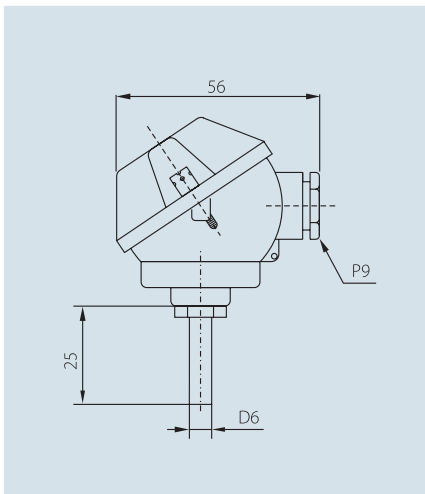

SENSOR INSTALLATION AND SERVICING

Prior to connecting the lead-in cable unscrew the lid of the metal connection head. The lead-in cable is then connected to the corresponding terminals through the loosend grommet according to the wiring diagram. Recommended wire cross-section is 0.35 to 1.5 mm², the outer diameter of the circular cross-section cable can range between 4 and 8 mm. In case the lead-in cable is laid in the vicinity of high voltage conductors or those supplying equipment creating disturbing electromagnetic field (e.g. inductive load equipment), a shielded cable should be used. To insure the ingress protection value of IP 54 the grommet has to be tightened and the lid has to be screwed on after connecting the lead-in cable. The openings for installation of stainless steel holder are drilled according to the dimensional draft, where hole diameters and distances between hole centers can be found. After installing and connecting the sensor to the appropriate electrical equipment, the sensor is ready to use. The sensor does not require any special servicing or maintenance. The sensors can be placed in any operating position but the grommet must not be directed upwards.

CUSTOMER SPECIFIC MODIFICATIONS

REGARDING TO SENSORS MANUFACTURED IN A STANDARD VERSION THE FOLLOWING PARAMETERS CAN BE MODIFIED:

- option of encasing two sensors
- option of encasing non-standard temperature sensors (DALLAS, TSic, KTY, SMT, etc.)
- A class precision (with the exception of sensors Ni 10000/5000, Ni 10000/6180, T1 = Ni 2226, termistor NTC 20 kΩ)
- option of three- or four-wire connection