

# **KIEN7009/SICOM3009A/SICOM3306 Industrial Ethernet SwitchHardware Installation Manual**

Publication Date: Mar. 2015

Version: V1.1

***KYLAND***

## **KIEN7009/SICOM3009A/SICOM3306 Industrial Ethernet Switch Hardware Installation Manual**

**Disclaimer:** Kyland Technology Co., Ltd. tries to keep the content of this manual as accurate and as updated as possible. This document is not guaranteed to be error-free, and we reserve the right to amend it without notice to users.

**All rights reserved.**

No part of this documentation may be excerpted, reproduced, translated, annotated or duplicated, in any form or by any means without the prior written permission of KYLAND Corporation.

**Copyright © 2015 Kyland Technology Co., Ltd.**

## Notice for Safety Operation

The product performs reliably as long as it is used according to the guidance. Artificial damage or destruction of the device should be avoided. Before using the device, read this notice carefully for personal and equipment safety. Please keep the manual for further reference. Kyland is not liable to any personal or equipment damage caused by violation of this notice.

- Do not place the device near water sources or damp areas. Keep the ambient relative humidity within the range from 5% to 95% (non-condensing).
- Do not place the device in an environment with high magnetic field, strong shock, or high temperature. Keep the working and storage temperatures within the allowed range.
- Install and place the device securely and firmly.
- Please keep the device clean; if necessary, wipe it with soft cotton cloth.
- Do not place any irrelevant materials on the device or cables. Ensure adequate heat dissipation and tidy cable layout without knots.
- Wear antistatic gloves or take other protective measures when operating the device.
- Avoid any exposed metal wires because they may be oxidized or electrified.
- Install the device in accordance with related national and local regulations.
- Before power-on, make sure the power supply is within the allowed range of the device. Overhigh voltage may damage the device.
- Power connectors and other connectors should be firmly interconnected.
- Do not plug in or out the power supply with wet hands. When the device is powered on, do not touch the device or any parts with wet hands.
- Before operating a device connected to a power cable, remove all jewelry (such as rings, bracelets, watches, and necklaces) or any other metal objects, because they may cause electric shock or burns.
- Do not operate the device or connect or disconnect cables during an electrical storm.
- Use compatible connectors and cables. If you are not sure, contact our sales or technical support personnel for confirmation.

- Do not disassemble the device by yourself. When an anomaly occurs, contact our sales or technical support personnel.
- If any part is lost, contact our sales or technical support personnel to purchase the substitute. Do not purchase parts from other channels.
- Dispose of the device in accordance with relevant national provisions, preventing environmental pollution.

In the following cases, please immediately shut down your power supply and contact your Kyland representative:

- Water gets into the equipment.
- Equipment damage or shell damage.
- Equipment operation or performance has abnormally changed.
- The equipment emits odor, smoke or abnormal noise.

The following information applies when operating this device in hazardous locations:

Suitable for use in Class I, Division 2, Groups A, B, C and D Hazardous Locations, or nonhazardous locations only.

Cet appareillage est utilisable dans les emplacements de Classe I, Division 2, Groupes A, B, C et D, ou dans les emplacements non dangereux seulement.

**WARNING: EXPLOSION HAZARD**

- Do not disconnect equipment while the circuit is live or unless the area is known to be free of ignitable concentrations.
- Substitution of any component may impair suitability for Class I, Division 2.
- Exposure to some chemicals may degrade the sealing properties of materials used in the following devices: Identification of the sealed devices.

**AVERTISSEMENT: RISQUE D'EXPLOSION**

- Avant de deconnecter l'equipement, couper le courant ou s'assurer que l'emplacement est designe non dangereux.
- La substitution de composants peut rendre ce materiel inacceptable pour les emplacements de Classe I, Division 2.

# Contents

1 Product Overview .....	1
2 Structure and Interface .....	5
2.1 Front Panel .....	5
2.2 Top Panel.....	7
3 Mounting .....	8
3.1 Dimension Drawing (Unit: mm) .....	8
3.2 Mounting Modes and Steps .....	9
3.2.1 DIN-Rail Mounting .....	9
3.2.2 Panel Mounting.....	10
4 Cable Connection.....	12
4.1 10/100Base-T(X) Ethernet Port.....	12
4.2 100Base-FX Ethernet Port .....	13
4.3 1000Base-X, 10/100/1000Base-T(X) SFP Slot .....	14
4.3.1 Gigabit SFP Optical Module .....	14
4.3.2 Gigabit SFP Electrical Module.....	16
4.4 Console Port .....	16
4.5 Grounding .....	17
4.6 Power Terminal Block .....	18
4.7 Alarm Terminal Block .....	20
5 Reset.....	22
6 LEDs .....	23
7 Switch Access .....	25
7.1 Access through Console Port.....	25
7.2 Access through Telnet .....	27
7.3 Access through Web .....	27
8 Basic Features and Specifications .....	29

# 1 Product Overview

KIEN7009/SICOM3009A/SICOM3306 includes a series of green low-consumption industrial Ethernet switches applied in the wind power, distribution network automation, subway PIS and AFC, power SCADA, sewage treatment, highway, metallurgy, hydroelectric power, photovoltaic generation, subway CBTC, plant automation, intelligent transportation, and many other industries.

The series switches provide Mini USB Console port, and supports Virtual Cable Test (VCT), one-touch recovery, and network management through Web, Telnet, and console port.

KIEN7009/SICOM3009A/SICOM3306 supports DIN rail mounting and panel mounting. KIEN7009 and SICOM3009A provides up to six 10/100Base-T(X) Ethernet ports and three 100Base-FX/100Base-TX ports. SICOM3306 provides up to six 10/100Base-T(X) Ethernet ports, two 100Base-FX Ethernet ports, and one 1000Base-X, 10/100/1000Base-T(X) SFP slot. For details, see the following table.

Table 1 KIEN7009 Models

Models	SICOM3009A-Ports-Connector-PS1-PS2
Code definition	Code option
Ports: GX, S/M, T	3S6T, 3M6T, 2S6T, 2M6T, 2S4T, 2M4T, 1S7T, 1M7T, 8T
	<p><b>Note:</b></p> <p><i>2S6T: two 100Base-FX ports, single mode; six 10/100Base-T(X) ports.</i></p> <p><i>2M6T: two 100Base-FX ports, multiple mode; six 10/100Base-T(X) ports.</i></p>
Connector: parameters for S/M	<p><b>Ports with M:</b></p> <p>ST05=ST connector, 1310nm, 5km</p> <p>SC05=SC connector, 1310nm, 5km</p> <p>FC05=FC connector, 1310nm, 5km</p> <p><b>Ports with S:</b></p> <p>ST40=ST connector, 1310nm, 40km</p>

	<p>SC40=SC connector, 1310nm, 40km</p> <p>FC40=FC connector, 1310nm, 40km</p> <p>SC60=SC connector, 1310nm, 60km</p> <p>SC80=SC connector, 1550nm, 80km</p> <p><b>Ports without S or M:</b></p> <p>N/A</p>
PS1-PS2: power input	<p>L2-L2 (24DCW, redundant power input, UL approved),</p> <p>L5-L5(12DCW, redundant power input)</p>

Table 2 SICOM3009A Models

<b>Models</b>	<b>SICOM3009A-Ports-Connector-PS1-PS2</b>
Code definition	Code option
Ports: GX, S/M, T	3S6T, 3M6T, 2S6T, 2M6T, 1S7T, 1M7T, 8T
	<p><b>Note:</b></p> <p><i>2S6T: two 100Base-FX ports, single mode; six 10/100Base-T(X) ports.</i></p> <p><i>2M6T: two 100Base-FX ports, multiple mode; six 10/100Base-T(X) ports.</i></p>
Connector: parameters for S/M	<p><b>Ports with M:</b></p> <p>ST05=ST connector, 1310nm, 5km</p> <p>SC05=SC connector, 1310nm, 5km</p> <p>FC05=FC connector, 1310nm, 5km</p> <p><b>Ports with S:</b></p> <p>ST40=ST connector, 1310nm, 40km</p> <p>SC40=SC connector, 1310nm, 40km</p> <p>FC40=FC connector, 1310nm, 40km</p> <p>SC60=SC connector, 1310nm, 60km</p> <p>SC80=SC connector, 1550nm, 80km</p> <p><b>Ports without S or M:</b></p>



	N/A
PS1-PS2: power input	L2-L2 (24DCW, redundant power input, UL approved), L5-L5(12DCW, redundant power input)

Table 3 SICOM3306 Models

<b>Models</b>	<b>SICOM3306-Ports-Connector-PS1-PS2</b>
Code definition	Code option
Ports: GX, S/M, T	1GX2S6T, 1GX2M6T, 3GX6T, 2GX6T, 1GX8T
	<p><b>Note:</b></p> <p><i>1GX2S6T: one 1000Base-X, 10/100/1000Base-T(X) SFP slot; two 100Base-FX ports, single mode; six 10/100Base-T(X) ports.</i></p> <p><i>1GX2M6T: one 1000Base-X, 10/100/1000Base-T(X) SFP slot; two 100Base-FX ports, multiple mode; six 10/100Base-T(X) ports.</i></p>
Connector: parameters for S/M	<p><b>Ports with M:</b></p> <p>ST05=ST connector, 1310nm, 5km</p> <p>SC05=SC connector, 1310nm, 5km</p> <p>FC05=FC connector, 1310nm, 5km</p> <p><b>Ports with S:</b></p> <p>ST40=ST connector, 1310nm, 40km</p> <p>SC40=SC connector, 1310nm, 40km</p> <p>FC40=FC connector, 1310nm, 40km</p> <p>SC60=SC connector, 1310nm, 60km</p> <p>SC80=SC connector, 1550nm, 80km</p> <p><b>Ports without S or M:</b></p> <p>N/A</p>
PS1-PS2: power input	L2-L2 (24DCW, redundant power input, UL approved), L5-L5(12DCW, redundant power input)

**Note:**

For the product information listed in the preceding table, we reserve the right to amend it without notice to users. To obtain the latest information, you can contact our sales or technical support personnel.

---

## 2 Structure and Interface



**Caution:**

To keep ports clean and ensure switch performance, you are advised to purchase the port dustproof shield (optional).

### 2.1 Front Panel

- Front Panel of KIEN7009-3S/M-6T and SICOM3009A-3S/M-6T

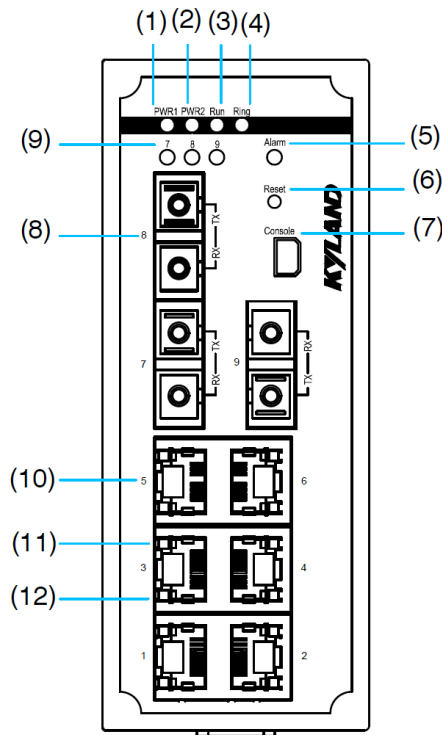

Figure 1 Front Panel of KIEN7009-3S/M-6T and SICOM3009A-3S/M-6T

Table 4 Description of the Front Panel of KIEN7009-3S/M-6T and SICOM3009A-3S/M-6T

No.	Identifier	Description
(1)	PWR1	Power 1 LED
(2)	PWR2	Power 2 LED
(3)	Run	Running LED
(4)	Ring	Ring LED
(5)	Alarm	Alarm LED
(6)	Reset	Reset button

(7)	Console	Console port
(8)	7-9	100Base-FX Ethernet ports
(9)	7-9	100Base-FX Ethernet port LEDs
(10)	1-6	10/100Base-T(X) Ethernet ports
(11)	--	10/100Base-T(X) Ethernet port speed LED (yellow)
(12)	--	10/100Base-T(X) Ethernet port connection status LED (green)

● Front Panel of SICOM3306-1GX-2S/M-6T

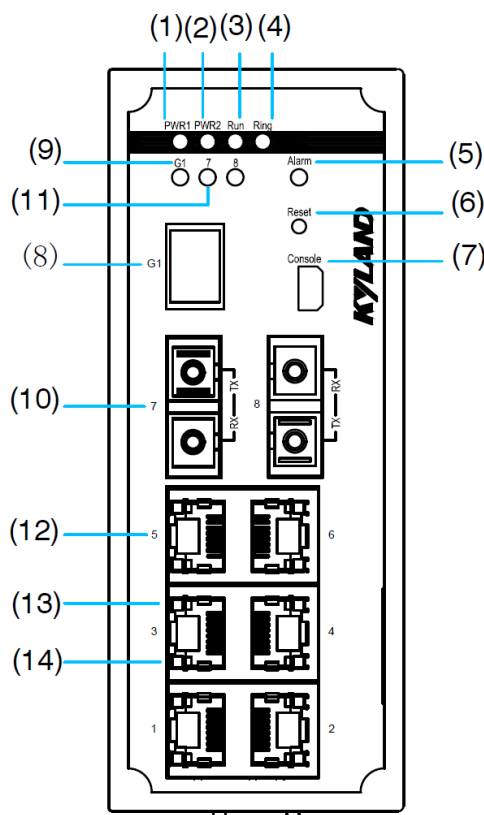

Figure 2 Front Panel of SICOM3306-1GX-2S/M-6T

Table 5 Description of the Front Panel of SICOM3306-1GX-2S/M-6T

No.	Identifier	Description
(1)	PWR1	Power 1 LED
(2)	PWR2	Power 2 LED
(3)	Run	Running LED
(4)	Ring	Ring LED
(5)	Alarm	Alarm LED

(6)	Reset	Reset button
(7)	Console	Console port
(8)	G1	Gigabit SFP slot
(9)	G1	Gigabit SFP slot LED
(10)	7-8	100Base-FX Ethernet ports
(11)	7-8	100Base-FX Ethernet port LEDs
(12)	1-6	10/100Base-T(X) Ethernet ports
(13)	--	10/100Base-T(X) Ethernet port speed LED (yellow)
(14)	--	10/100Base-T(X) Ethernet port connection status LED (green)

## 2.2 Top Panel

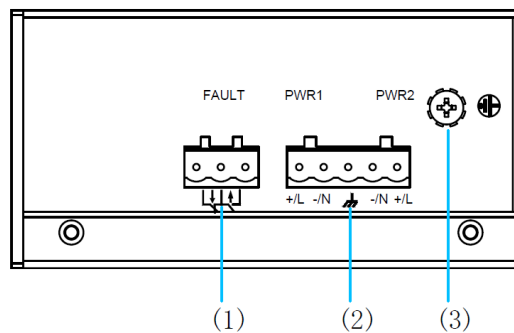

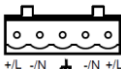



Figure 3 Top Panel

Table 6 Description of the Top Panel

No.	Identifier	Description
1	<p>FAULT</p> 	Alarm terminal block
2	<p>PWR1 PWR2</p> 	Power terminal block
3		Grounding screw

### 3 Mounting

#### 3.1 Dimension Drawing (Unit: mm)

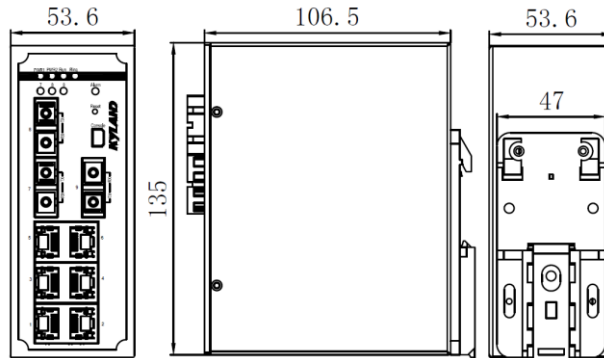

Figure 4 Dimensions for DIN-rail Mounting

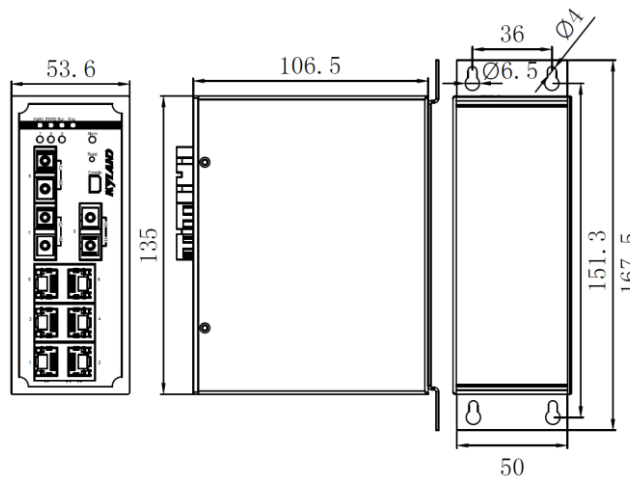

Figure 5 Dimensions for Panel Mounting



**Caution:**

- The preceding figure uses SICOM3009A-3S/M-6T as an example. The other models of KIEN7009/SICOM3009A/SICOM3306 have the same dimensions with SICOM3009A-3S/M-6T.
- As part of the heat dissipation system, the switch housing becomes hot during operation. Please use caution when coming in contact and avoid covering the switch housing when the switch is running.
- The figures in this manual are only for reference.

### 3.2 Mounting Modes and Steps

The device supports both DIN-rail mounting and panel mounting. Before installation, make sure that the following requirements are met.

- 1) Environment: ambient temperature (see 8 Basic Features and Specifications), ambient relative humidity (5% to 95%, non-condensing)
- 2) Power requirement: The power input is within the voltage range of the switch.
- 3) Grounding resistance:  $<5\Omega$
- 4) No direct sunlight, distant from heat source and areas with strong electromagnetic interference.

#### 3.2.1 DIN-Rail Mounting

- Mounting

Step 1: Select the mounting position for the device and guarantee adequate space and heat dissipation for it (dimensions: 53.6mm×135mm×106.5mm).

Step 2: Insert the connecting seat onto the top of the DIN rail, and push the bottom of the device inward and upward to ensure the DIN rail fits in the connecting seat. Make sure the device is firmly installed on the DIN rail, as shown in the following figure.

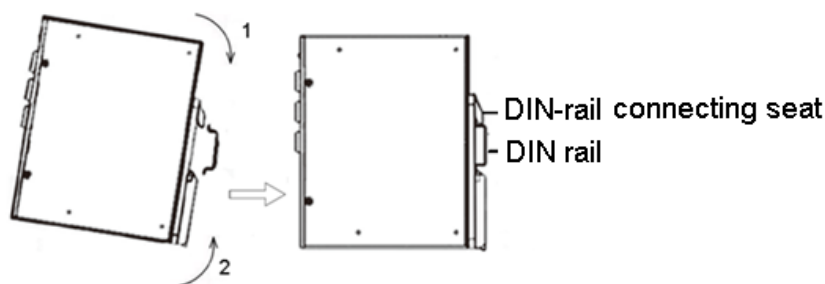

Figure 6 DIN-Rail Mounting

- Dismounting

Step 1: Insert the head of a screwdriver into the opening of the spring locking piece at the bottom from the left. Lift the handle of the screwdriver to open the spring locking piece of the connecting seat, as shown on the left of the following figure.

Step 2: Move the device in direction 2 until the bottom of the device is detached from the DIN rail. Then move the device in direction 3 and uplift the device until the top of the

connecting seat is detached from the DIN rail. In this way, the device is removed from the DIN rail completely.

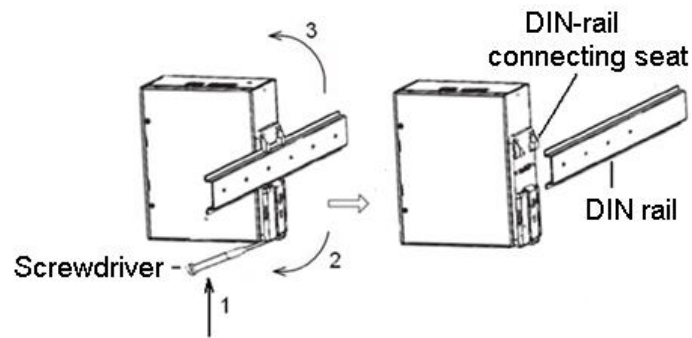

Figure 7 DIN-Rail Dismounting

### 3.2.2 Panel Mounting



**Caution:**

To adopt panel mounting, you need to purchase the plate for panel mounting (optional).

- Mounting

Step 1: Use screws to fix the plate for panel mounting to the rear panel of the device.

Step 2: Select the mounting position (on a wall or inner wall of a cabinet) for the device and guarantee adequate space and heat dissipation for it (dimensions: 53.6mm×135mm×106.5mm).

Step 3: Punch four holes in the selected position according to the dimensions for panel mounting. Insert four screws into the four holes respectively, and turn the screws with a screwdriver until about a 5mm distance is left between each screw head and the wall.

Step 4: Align the four mounting holes on the plate for panel mounting with the four screws. Make the screws pass through the  $\Phi 6.5$  positions in the following figure. Move the device in direction 1 until the four screws are in the  $\Phi 4$  positions. Then tighten the screws to complete mounting.



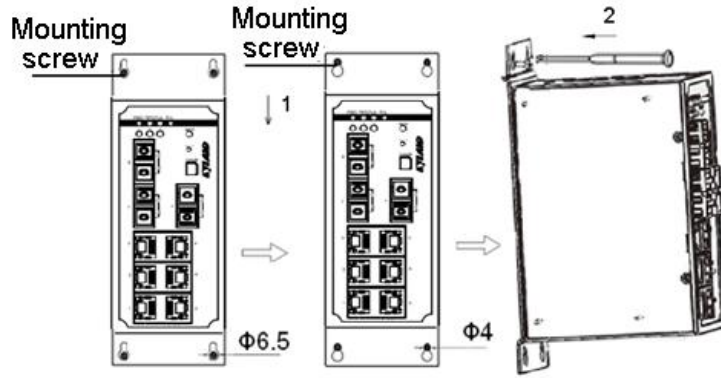

Figure 8 Panel Mounting

- Dismounting

Step 1: Loosen the four screws with a screwdriver. Move the device upward until the four screws are in the  $\Phi 6.5$  positions in the following figure. Then remove the plate for panel mounting from the four screws to detach the device from the wall or inner wall of the cabinet.

Step 2: Loosen the screws completely with a screwdriver. Remove them from the wall or inner wall of the cabinet. Then remove the plate for panel mounting from the rear panel to complete dismounting the device.

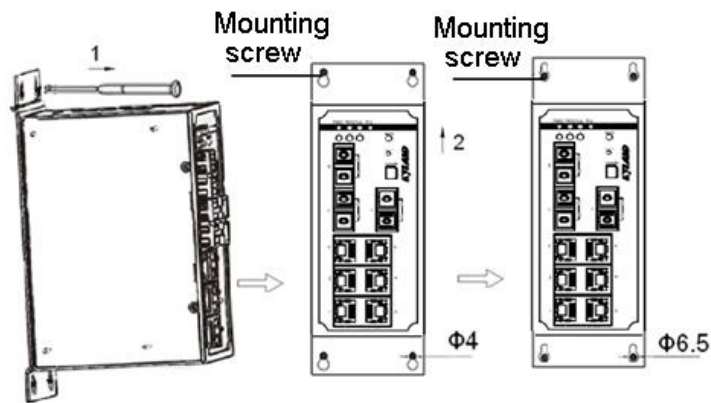

Figure 9 Panel Dismounting

## 4 Cable Connection

### 4.1 10/100Base-T(X) Ethernet Port

10/100Base-T(X) Ethernet port is equipped with RJ45 connector. The port is self-adaptive. It can automatically configure itself to work in 10M or 100M state, full or half duplex mode. The port can also adapt to MDI or MDI-X connection automatically. You can connect the port to a terminal or network device with a straight-through or cross-over cable.

- Pin Definition

The following figure shows the pin numbers of the RJ45 port.

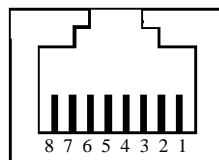

Figure 10 RJ45 Port

The following table lists the pin definitions of the 10/100Base-T(X) RJ45 port.

Table 7 Pin Definitions of 10/100Base-T(X) RJ45 Port

Pin	MDI-X Signal	MDI Signal
1	Receive Data+ (RD+)	Transmit Data+ (TD+)
2	Receive Data- (RD-)	Transmit Data- (TD-)
3	Transmit Data+ (TD+)	Receive Data+ (RD+)
6	Transmit Data- (TD-)	Receive Data- (RD-)
4, 5, 7, 8	Unused	Unused



**Note:**

"+" and "-" indicate level polarities.

● Wiring Sequence

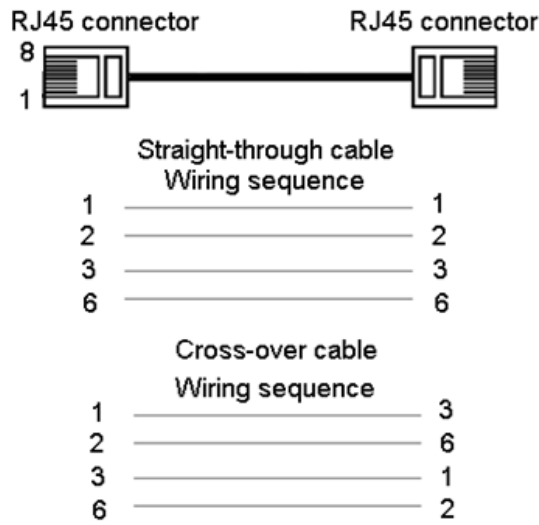

Figure 11 Connection Using Straight-through/Cross-over Cable



**Note:**

The color of the cable for RJ45 connector meets the 568B standard: 1-orange and white, 2-orange, 3-green and white, 4-blue, 5-blue and white, 6-green, 7-brown and white, and 8-brown.

### 4.2 100Base-FX Ethernet Port

100Base-FX port is equipped with FC/ST/SC connector, and each port consists of TX (transmit) port and RX (receive) port. To enable communication between Device A and Device B, connect the TX (transmit) port of Device A to the RX (receive) port of Device B, and the RX (receive) port of Device A to the TX (transmit) port of Device B. The following figure shows the cable connection of the 100Base-FX Ethernet port. (The SC port is used as an example. ST/FC cable connection is the same with SC.)

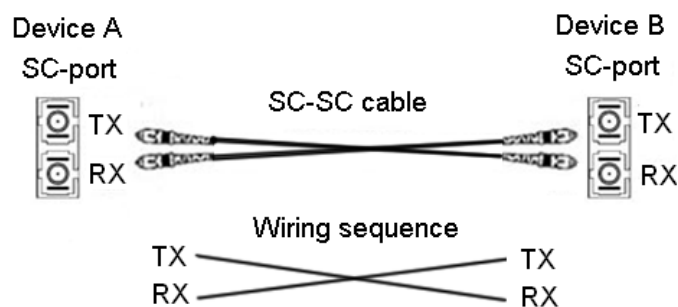

Figure 12 Cable Connection of 100Base-FX Ethernet Port



**Caution:**

A laser is used to transmit signals in fiber cables. The laser meets the requirements of level 1 laser products. Routine operation is not harmful to your eyes, but do not look directly at the 100Base-FX Ethernet port when the switch is powered on.

### 4.3 1000Base-X, 10/100/1000Base-T(X) SFP Slot

1000Base-X, 10/100/1000Base-T(X) SFP slot (Gigabit SFP slot): You can enable data transmission only after inserting an SFP optical/electrical module into the slot and connecting cable properly. The following table lists the Gigabit SFP optical/electrical modules (optional) supported by the series switches.

Table 8 Gigabit SFP Optical/Electrical Modules for SICOM3306

Model	Interface	MM/ SM	Connector	Center Wavelength (CWL)	Transmission Distance
IGSFP-M-SX-LC-850-0.55	1000Base-X port	MM	LC	850nm	0.55km
IGSFP-S-LX-LC-1310-10	1000Base-X port	SM	LC	1310nm	10km
IGSFP-S-LH-LC-1310-40	1000Base-X port	SM	LC	1310nm	40km
IGSFP-S-ZX-LC-1550-80	1000Base-X port	SM	LC	1550nm	80km
IG-FSFP-M-LX-LC-1310-2	100Base-FX port	MM	LC	1310nm	2km
IG-FSFP-S-LX-LC-1310-10	100Base-FX port	SM	LC	1310nm	10km
IGSFP-10/100/1000BASE-T-RJ45	10/100/1000Base-T(X) port (self-adaptive)	--	RJ45 connector	--	--

#### 4.3.1 Gigabit SFP Optical Module

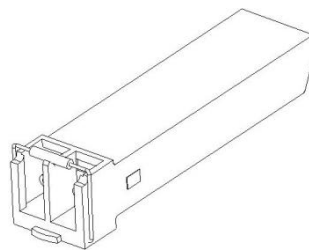

Figure 13 Gigabit SFP Optical Module

Gigabit SFP optical module is equipped with LC connector, and each port consists of a TX

(transmit) port and an RX (receive) port. To enable communication between Device A and Device B, connect the TX (transmit) port of Device A to the RX (receive) port of Device B, and the RX (receive) port of Device A to the TX (transmit) port of Device B. The following figure shows the cable connection of the Gigabit SFP optical module.

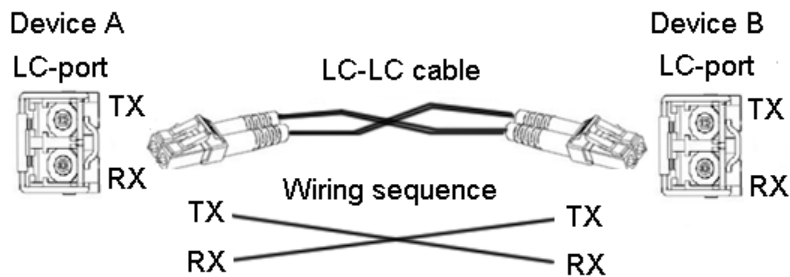

Figure 14 Cable Connection of Gigabit SFP Optical Module

● How to Connect the Gigabit SFP Optical Module

Insert the SFP optical module into the SFP slot in the switch, and then plug the optical fiber into the TX port and RX port of the SFP module.

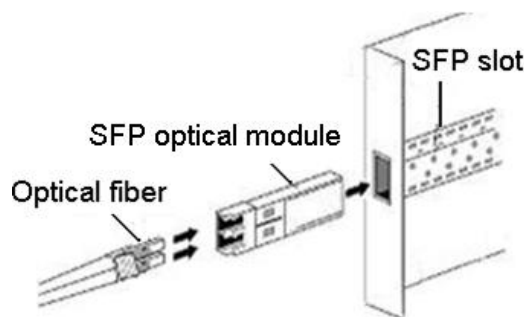

Figure 15 Connecting the Gigabit SFP Optical Module

How to Determine the RX Port and TX Port of Gigabit SFP Optical Module

1. Insert the two connectors in one end of optical fiber into the gigabit SFP module, and those in the other end of the optical fiber into the SFP module of another switch.
2. View the corresponding port connection status LED in the front panel:

If the LED blinks, the link is connected.

If the LED is off, the link is not connected. This may be caused by incorrect connection of the TX and RX ports. In this case, swop the two connectors in the one end of the optical fiber.

### 4.3.2 Gigabit SFP Electrical Module

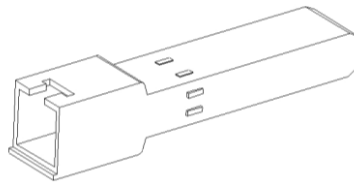

Figure 16 Gigabit SFP Electrical Module

- How to Connect the Gigabit SFP Electrical Module

Insert the SFP electrical module into the SFP slot in the switch, and then plug the RJ45 connector of the twisted pair into the SFP module.

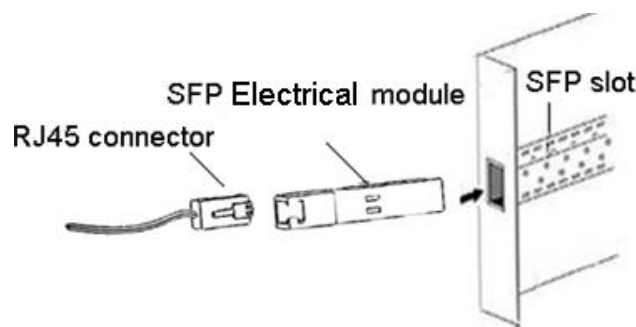

Figure 17 Connecting the Gigabit SFP Electrical Module

## 4.4 Console Port



**Caution:**

To use the console port, you need to purchase the USB console cable (optional).

The device provides the console port on the front panel. To use the console port, you need to install Mini USB driver.exe (you can find the program in the delivered CD) on the computer. Then use the USB console cable to connect the console port of the switch to the USB port of the computer. You can configure, maintain, and manage the switch by running the Hyper Terminal in the Windows OS of the computer.



Figure 18 Console Port

- Mini USB Connector

The following figure shows the pin numbers of the Mini USB connector.



Figure 19 Mini USB Connector

The following table lists the pin definitions of the Mini USB connector.

Table 9 Pin Definitions of the Mini USB Connector

Mini USB Pin	Definition
1	VBUS
2	D-
3	D+
4	ID
5	Grounding

- USB Connector

The following figure shows the pin numbers of the USB connector.

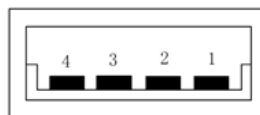

Figure 20 USB Connector

The following table lists the pin definitions of the USB connector.

Table 10 Pin Definitions of the USB Connector

USB Pin	Definition
1	VBUS
2	D-
3	D+
4	Grounding

## 4.5 Grounding

Grounding protects the device from lightning and interference. Therefore, you must ground the device properly. You need to ground the device before it is powered on and disconnect the grounding cable after the device is powered off.

There is a grounding screw on the top panel of the device. The screw is for chassis grounding. After crimping one end of the grounding cable to a cold pressed terminal, secure

the end to the grounding screw and connect the other end to the earth firmly.

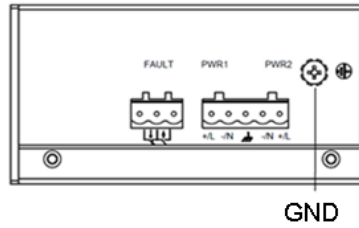

Figure 21 Grounding



**Note:**

Cross-sectional area of the chassis grounding cable  $>2.5\text{mm}^2$ ; Grounding resistance  $<5\Omega$ .

### 4.6 Power Terminal Block

There is a power terminal block on the top panel of the switch. You need to connect the power cable to the terminal block to provide power for the switch. The switch supports both single power supply and dual power supply for redundancy with a 5-pin 5.08mm-spacing plug-in terminal block. When the dual power supply is used and one power input is faulty, the switch can continue operating properly, thereby improving network reliability.



**Note:**

- Grounding resistance  $<5\Omega$ .
- Use copper conductors only, temperature rating  $75^\circ\text{C}$  only.

- 5-Pin 5.08mm-Spacing Plug-in Terminal Block

The following figure lists the pin definitions of the 5-pin 5.08mm-spacing plug-in terminal block.

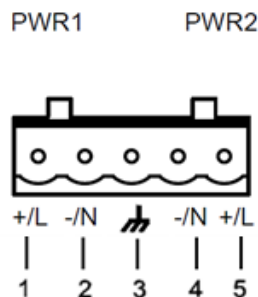

Figure 22 5-Pin 5.08mm-Spacing Plug-in Terminal Block (Socket)

The following figure lists the pin definitions of the 5-pin 5.08mm-spacing plug-in terminal block.



Table 11 Pin Definitions of 5-Pin 5.08mm-Spacing Plug-in Terminal Block

No.	DC Definition	AC Definition
1	PWR1: +	PWR1: L
2	PWR1: -	PWR1: N
3	PGND	PGND
4	PWR2: -	PWR2: N
5	PWR2: +	PWR2: L

● Wiring and Mounting

Step 1: Ground the device properly according to section 4.5.

Step 2: Remove the power terminal block from the device.

Step 3: Insert the power cable into the power terminal block according to Table 11 to fix the power cable.

Step 4: Insert the terminal with the connected cable into the terminal block on the device.

Step 5: Connect one end of the power cable to an external power supply system (with the allowed power range). If the power LED on the front panel of the switch turns on, the power supply is connected properly.

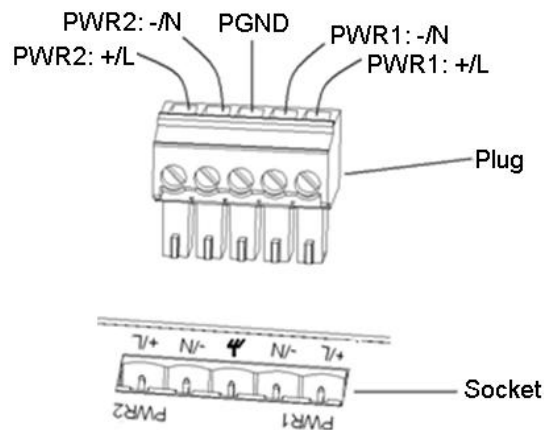

Figure 23 Cable Connection of 5-Pin 5.08mm-Spacing Plug-in Terminal Block

Wiring and Mounting should meet following specifications.

Table 12 Wiring and Mounting Specifications

Terminal Type	Required Torque	Wire Range (AWG)
Terminal Block Plug	4.5-5.0 lb-in for WEIDMUELLER terminal block	12-24
	5-7 lb-in for PHOENIX terminal block	



**Caution:**

- The switch supports 12DCW and 24DCW(UL approved) power input. Before connecting the device to power supply, make sure that the power input meets the power requirement. If connected to an incorrect power input, the device may be damaged.
- To comply with UL restrictions, this equipment must be powered from a source compliant with Class 2.



**Warning:**

- Do not touch any exposed conducting wire, terminal, or component with a voltage warning sign, because it may cause damage to humans.
- Do not remove any part or plug in or out any connector when the device is powered on.

## 4.7 Alarm Terminal Block

The device provides the alarm terminal block on the top panel for alarm output. When the switch works properly, the normally-open contacts of the alarm relay are closed and the normally-closed contacts are open; when an alarm occurs, the normally-open contacts are open and the normally-closed contacts are closed. The alarm is outputted through a 3-pin 5.08mm spacing plug-in terminal block.



**Note:**

Use copper conductors only, temperature rating 75°C only.

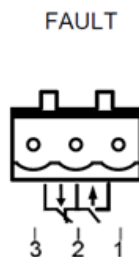

Figure 24 Alarm Terminal Block (Socket)

Electrical parameters of the relay:

Maximum voltage: 250VAC/220VDC

Maximum current: 2A

Maximum power: 60W

Maximum dielectric voltage withstand: 2KV



**Note:**

Pin 1 and pin 2 are normally-open contacts; pin 2 and pin 3 are normally-closed contacts. When the switch works properly, pin 1 and pin 2 are closed, and pin 2 and pin 3 are open; when an alarm occurs, pin 1 and pin 2 are open, and pin 2 and pin 3 are closed.

● **Wiring and Mounting**

Step 1: Remove the alarm terminal block from the switch.

Step 2: Secure the three cables for alarm into the alarm terminal block in the required sequence.

Step 3: Insert the alarm terminal block into its socket.

Wiring and Mounting should meet following specifications.

Table 13 Wiring and Mounting Specifications

Terminal Type	Required Torque	Wire Range (AWG)
Terminal Block Plug	4.5-5.0 lb-in for WEIDMUELLER terminal block	12-24
	5-7 lb-in for PHOENIX terminal block	

## 5 Reset

The device provides a Reset button on the front panel. The button can be used to restart the device or restore factory default settings.

You can restart the device by pressing and holding the button for one second.

You can restore factory default settings (including the IP address) by pressing and holding the button for five seconds. The default IP address is 192.168.0.2.

---

**Caution:**

To restart the device only, do not press and hold the button for five seconds or more, because the operation will restore factory default settings.

---

## 6 LEDs

The following table lists the descriptions of the front panel LEDs.

Table 14 Front Panel LEDs

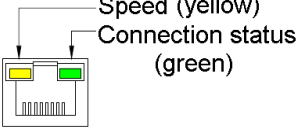
LED	State	Description
Power 1 LED	On	Power 1 is connected and operates properly.
	Off	Power 1 is not connected or operates abnormally.
Power 2 LED	On	Power 2 is connected and operates properly.
	Off	Power 2 is not connected or operates abnormally.
Running LED	Blinking	The CPU operates properly.
	Off	The CPU does not start up.
Ring LED	On	Master station (DT-Ring)/Root (DRP)
	Blinking	Slave station (DT-Ring)/B-Root or Normal (DRP)
	Off	No ring
Alarm LED	On	An alarm occurs.
	Off	No alarm occurs.
100Base-FX Ethernet port LED	On	Effective port connection
	Blinking	Ongoing network activities
	Off	No effective port connection
Gigabit SFP slot LED	On	Effective port connection
	Blinking	Ongoing network activities
	Off	No effective port connection
		
10/100Base-T(X) Ethernet port speed LED (yellow)	On	100M working state (100Base-TX)
	Off	10M working state (10Base-T) or no connection
10/100Base-T(X) Ethernet port connection status LED (green)	On	Effective port connection
	Blinking	Ongoing network activities

---

	Off	No effective port connection
--	-----	------------------------------

## 7 Switch Access

You can access the switch in any of the following ways:

### 7.1 Access through Console Port

Step 1: Install Mini USB driver.exe. You can find the program in the delivered CD.

Step 2: Connect the USB port of the PC to the console port of the switch with the USB console cable.

Step 3: Open the Hyper Terminal in the Windows OS. On the desktop, click Start → All Programs → Accessories → Communications → Hyper Terminal.

Step 4: Create a connection "Switch", as shown in the following figure.



Figure 25 Creating a Connection

Step 5: Connect the communication port in use, as shown in the following figure.



Figure 26 Selecting the Serial Port in Use



**Note:**

To confirm the communication port in use, right-click [My Computer] and select [Property]. Click [Hardware] → [Device Manager] → [Port] to view the communication port.

Step 6: Set port parameters (Bits per second: 115200, Data bits: 8, Parity: None, Stop bits: 1, and Flow control: None), as shown in the following figure.



Figure 27 Port Settings

Step 7: Click OK to enter the switch CLI. Then you can run the following commands to



perform operations.

Table 15 CLI Commands

View	Command	Description
User view	SWITCH>enable	Enter the management view.
Management view	SWITCH#show interface	Query the IP address of the switch.
Management view	SWITCH#show version	Query the version of the switch.
Management view	SWITCH#reboot	Restart the switch.
Management view	SWITCH#load default	Restore the factory default settings
Management view	SWITCH#config terminal	Enter the configuration view.

## 7.2 Access through Telnet

Step 1: Connect the network port of the PC to the RJ45 port of the switch with an RJ45-RJ45 cable.

Step 2: Enter "telnet *IP address*" in the Run dialog box. For example, if the IP address of the switch is 192.168.0.2 (default IP address of a Kyland switch), enter "telnet 192.168.0.2" in the dialog box.

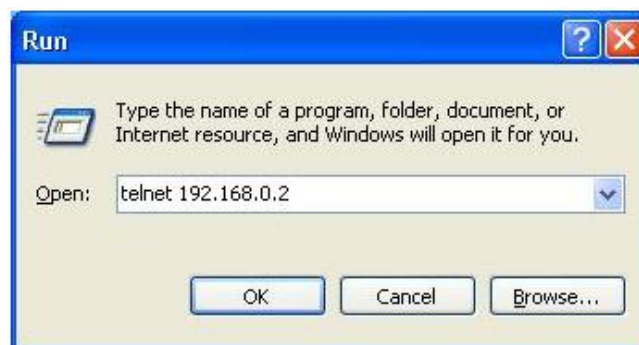

Figure 28 Access through Telnet

Step 3: Click OK. The Telnet CLI is displayed. Then you can enter commands (as shown in Table 15) to perform operations.

## 7.3 Access through Web

Step 1: Connect the network port of the PC to the RJ45 port of the switch with an RJ45-RJ45 cable.

Step 2: Enter the IP address of the switch in the address box of the browser. The user login interface is displayed. You can log in to the Web UI by default user name "admin" and password "123".

---

**Note:**

- IE8.0 or a later version is recommended.
  - For details about how to access the switch and other operation, refer to the Web operation manual in the delivered CD.
-

## 8 Basic Features and Specifications

### Power Requirements

Power Identifier	Rated Voltage Range	Maximum Voltage Range
L5(12DCW)	12-24VDC	9-36VDC
L2(24DCW, UL approved)	24-48VDC	18-72VDC 18-60VDC(UL approved)
Terminal block	5-pin 5.08mm-spacing plug-in terminal block	

### Rated Power Consumption

Rated Power Consumption	KIEN7009: 8.1W (MAX) SICOM3009A: 8.1W (MAX) SICOM3306: 9.1W (MAX)
-------------------------	---

### Physical Characteristics

Housing	Metal, fanless
Installation	DIN-rail mounting or panel mounting
Dimensions (W×H×D)	53.6mm×135mm×106.5mm(excluding the connector, DIN rail, and component for panel mounting)
Weight	0.76Kg

### Environmental Limits

Ambient temperature	-40°C ~+85°C Only L2 model gets UL certification with the max ambient temperature of 75°C.
Storage temperature	-40°C ~+85°C
Ambient relative humidity	5%~95% (non-condensing)

### MTBF

MTBF	KIEN7009: 385,000h SICOM3009A: 350,877h SICOM3306: 410,000h
------	---

### Warranty

---

Warranty	5 years
----------	---------

---



**Note:**

Signal output rated voltage is less than 30 volts.

---

## ***KYLAND***

FAX: +86-10-88796678

Website: <http://www.kyland.com>

Email: [support@kyland.com](mailto:support@kyland.com)

For more information about KYLAND products,  
please visit our website:

<http://www.kyland.com>