

Electric Gas Cooler Series EC[®]

ECM

Instruction Manual
Version 1.02.02



**Dear customer,**

Thank you for buying our product. In this instruction manual you will find all necessary information about this M&C product. The information in the instruction manual is fast and easy to find, so you can start using your M&C product right after you have read the manual.

If you have any question regarding the product or the application, please don't hesitate to contact M&C or your M&C authorized distributor. You will find all the addresses in the appendix of this manual.

For additional information about our products and our company, please go to M&C's website www.mc-techgroup.com. There you will find the data sheets and manuals of our products in German and English.

This Operating Manual does not claim completeness and may be subject to technical modifications.

© 06/2024 **M&C TechGroup** Germany GmbH. Reproduction of this document or its content is not allowed without permission from **M&C ECM**® is a registered trademark.

With the release of this version all older manual versions will no longer be valid. The German instruction manual is the original instruction manual. In case of arbitration only the German wording shall be valid and binding.

Version: 1.02.02

Content

1	General information	5
2	Declaration of conformity	5
3	Safety instructions	6
4	Warranty	6
5	Used terms and signal indications	7
6	Introduction	9
6.1	Serial number	9
7	Application	10
8	Technical Data	11
8.1	For basic cooler ECM without heat exchanger	11
8.2	Options for basic cooler ECM	12
9	Description	12
10	Function	13
11	Reception and storage	14
12	Installation instructions	15
13	Hose connections	15
14	Electrical connections	17
15	Preparations for commissioning	18
16	Start-up	18
17	Closing down	19
18	Maintenance	20
18.1	Adding and replacing the heat exchangers.....	20
18.2	Cleaning the fins of the condenser.....	21
18.3	Maintenance of the optional mounted peristaltic pump(s), type SR25.2.....	21
18.3.1	Mounting instructions for SR25.2 peristaltic pump (optional).....	22
18.3.2	Changing the pump tubing	23
18.3.3	Changing contact pulleys and springs	24
18.3.4	Reassembly of the driver.....	26
18.3.5	Cleaning the pump head	26
18.3.6	Repair information for integrated peristaltic pump type SR25.2 (optional).....	26
19	Operating of the built-in electronic temperature controller	27
19.1	Temperature controller version until March 2022.....	27
19.1.1	Changing the set value.....	28
19.2	Temperature controller version starting April 2022	28
19.2.1	Changing the set value.....	28
19.3	Temperature controller version starting 09.2023	28
19.3.1	Changing the setpoint.....	29
20	Trouble shooting	29
21	Proper disposal of the device	30
22	Spare parts list	31
23	Risk assessment	32
24	Appendix	35

List of illustrations

Figure 1	Type plate.....	9
Figure 2	Application example of the ECM.....	10
Figure 3	ECM-2G.....	12
Figure 4	Schematic diagram of the heat exchanger function.....	14
Figure 5	Gas and condensate connections.....	15
Figure 6	Electrical sockets alarm contact.....	17
Figure 7	SR25.2: Mounting distance between front panel and pump motor.....	22
Figure 8	Changing the pump tubing.....	23
Figure 9	Different pump tube sizes.....	24
Figure 10	Disassembly of pump head and driver.....	24
Figure 11	Check of axes and rolls.....	25
Figure 12	Hysteresis behavior of the status alarm at factory settings.....	27
Figure 13	Front view of the temperature controller version until 03.2022.....	27
Figure 14	Front view of the temperature controller version starting 04.2022.....	28
Figure 15	Front view of the temperature controller version starting 09.2023.....	28
Figure 16	Overview risk assessment.....	33
Figure 17	Dependency of gas outlet dew point at a gas inlet point of 60 °C [140 °F].....	35
Figure 18	Circuit diagram ECM.....	36
Figure 19	ECM compressor connection.....	37

Head Office

M&C TechGroup Germany GmbH ♦ Rehhecke 79 ♦ 40885 Ratingen ♦ Germany
Telephone: 02102 / 935 - 0
Fax: 02102 / 935 - 111
E - mail: info@mc-techgroup.com
www.mc-techgroup.com

1 GENERAL INFORMATION

The product described in this instruction manual has been built and tested in our production facility. All M&C products are packed to be shipped safely. To ensure the safe operation and to maintain the safe condition, all instructions and regulations stated in this instruction manual need to be followed. This instruction manual includes all information regarding proper transportation, storage, installation, operation and maintenance of this product by qualified personnel. Follow all instructions and warnings closely. Read this manual carefully before commissioning and operating the device. If you have any questions regarding the product or the application, please don't hesitate to contact M&C or your M&C authorized distributor.

2 DECLARATION OF CONFORMITY



The product described in this operating manual complies with the following EU directives:

EMV-Instruction

The requirements of the EU directive 2014/30/EU 'Electromagnetic compatibility' are met.

Low Voltage Directive

The requirement of the EU directive 2014/35/EU 'Low Voltage Directive' are met.
The compliance with this EU directive has been examined according to DIN EN 61010.

Declaration of conformity

The EU Declaration of conformity can be downloaded from the **M&C** homepage or directly requested from **M&C**.



The product described in this operating manual complies with the following CSA directive:
CAN/CSA-C22.2 No.61010.1-04 UL Std.61010-1 (3 Edition).



3 SAFETY INSTRUCTIONS

Please take care of the following basic safety procedures when mounting, starting up or operating this equipment:

- Read this operating manual before starting up and use of the equipment. The information and warnings given in this operating manual must be heeded.
- Any work on electrical equipment is only to be carried out by trained specialists as per the regulations currently in force.
- Attention must be paid to the requirements of VDE 0100 (IEC 364) when setting high-power electrical units with nominal voltages of up to 1000 V, together with the associated standards and stipulations.
- Check the details on the type plate to ensure that the equipment is connected to the correct mains voltage.
- Protection against touching dangerously high electrical voltages:
Before opening the equipment, it must be switched off and hold no voltages. This also applies to any external control circuits that are connected.
- The device is only to be used within the permitted range of temperatures and pressures.
- Check that the location is weather-protected. It should not be subject to either direct rain, sun or moisture.
- Do not use the device in hazardous areas.
- Installation, maintenance, inspections and any repairs of the devices must be carried out only by qualified skilled personnel in compliance with the current regulations.

4 WARRANTY

In case of a device failure, please contact immediately M&C or your M&C authorized distributor.

We have a warranty period of 12 months from the delivery date. The warranty covers only appropriately used products and does not cover the consumable parts. Please find the complete warranty conditions in our terms and conditions.

The warranty includes a free-of-charge repair in our production facility or the free replacement of the device. If you return a device to M&C, please be sure that it is properly packaged and shipped with protective packaging. The repaired or replaced device will be shipped free of delivery charges to the point of use.

5 USED TERMS AND SIGNAL INDICATIONS



The 'Danger' warning sign indicates that death, serious injury and/or significant material damage will be the consequence, if the appropriate precautions should not be taken.



The 'Warning' warning sign indicates that death, serious injury or damage to property may occur if the relevant precautionary measures are not observed.



The 'Caution' warning sign indicates that slight personal injury can occur if the appropriate safety precautions are not observed.

Caution

'Caution' indicates that damage to property can occur if the appropriate safety precautions are not observed.

Attention

'Attention' indicates that an unintended result or situation can occur if the corresponding information is not taken into account.



'Note' indicates important information relating to the product or highlights parts of the documentation for special attention.

Qualified personnel

'Qualified personnel' are experts who are familiar with the installation, mounting, commissioning and operation of these types of products.



High voltages!
Protect yourself and others against damage which might be caused by high voltages.



Toxic!
Acute toxicity (oral, dermal, inhalation)! Toxic when in contact with skin, swallowed or inhaled.



Corrosive!
These substances destroy living tissue and equipment upon contact.
Do not breathe vapors; avoid contact with skin and eyes.



Contains gas under pressure. Do not open container!
Check pressure before opening container, and adjust pressure to atmospheric pressure.



Hot surface!
Contact may cause burn! Do not touch!



Caution, risk of being crushed due to rotating parts.
Do not open the device. Use personal protective equipment (PPE).



Wear protective gloves!
Working with chemicals, sharp objects or extremely high temperatures requires wearing protective gloves.



Wear safety glasses!
Protect your eyes while working with chemicals or sharp objects. Wear safety glasses to avoid getting something in your eyes.



Wear protective clothes!
Working with chemicals, sharp objects or extremely high temperatures requires wearing protective clothes.



Use foot protection



Use safety helmet and full protective goggles

6 INTRODUCTION

The **M&C** cooler **ECM** is used for applications where interfering moisture loading in the sample gas is to be expected.

By lowering to a very low stable dew point, condensation is prevented in the analyzer and a fluctuating measurement value due to water vapour cross sensitivities or volumetric errors is avoided.

6.1 SERIAL NUMBER

The type plate with the serial number is located on the right side of the cooler housing (wall-mount). Please always quote the serial number in case of queries and spare parts orders.

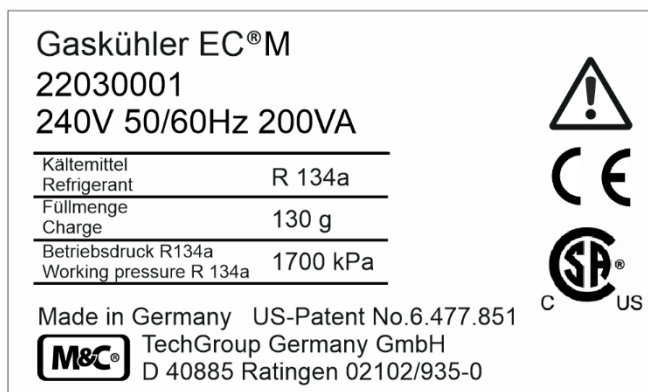

Figure 1 Type plate

7 APPLICATION

Figure 2 shows a typical example of an application for installation of an **ECM** gas cooler unit.

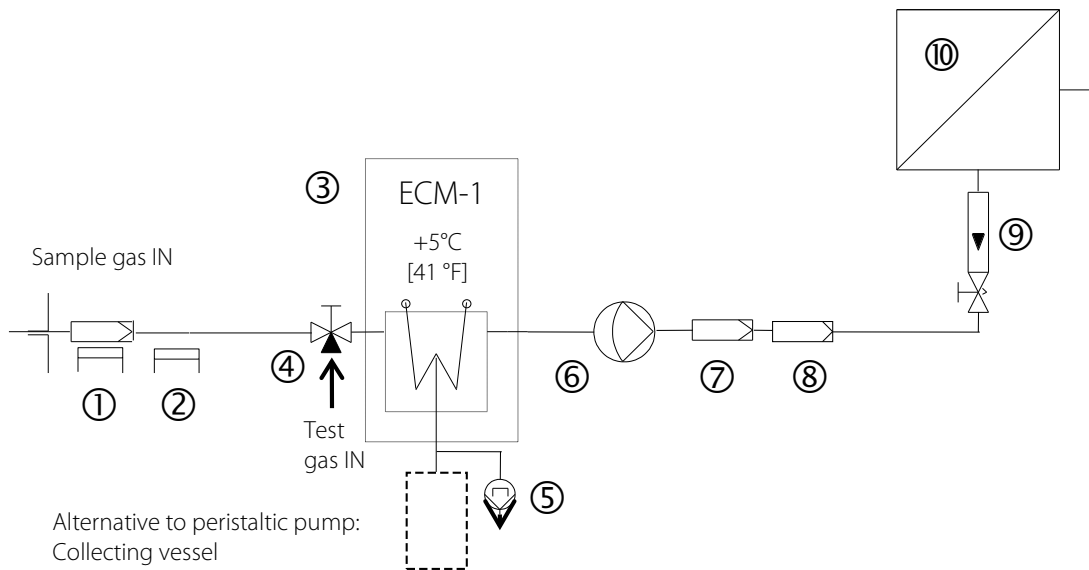



Figure 2 Application example of the ECM

- | | | |
|------------------------|----------------------------------|-------------------|
| ① Sample probe SP | ② Heated sample line | ③ ECM cooler |
| ④ 3-way ball valve | ⑤ Peristaltic pump SR25 (option) | ⑥ Membran pump |
| ⑦ Super fine filter FP | ⑧ Aerosol filter CLF-5 | ⑨ Flow meter FM10 |
| ⑩ Analyzer | | |

The gas to be measured is taken from the **ECM** gas cooler ③ by a gas sample probe ① via a heated sample line ② and cooled down to a dew point of +5 °C [41 °F]. The super-fine filter ⑦ located afterwards removes solid particles. For increased operating safety of the entire system we recommend installing a super-fine filter ⑦ with a liquid alarm sensor. If required an aerosol filter ⑧ can be installed in front of the flow meter ⑨. The gas thus treated can now be passed into the analyzer ⑩.

8 TECHNICAL DATA

8.1 FOR BASIC COOLER ECM WITHOUT HEAT EXCHANGER

Gas cooler series EC [®]	Version ECM-1	Version ECM-2
Part No. for 240 V, 50-60 Hz	02K7500X*	02K7510X*
Part No. for 120 V, 50-60 Hz	02K7500Xa*	02K7510Xa*
Amount of possible heat exchangers	1 heat exchanger	2 heat exchangers
Sample outlet dew point	Range of adjustment: +2 to +7 °C [35.6 to 44.6 °F], factory setting: +5 °C [41 °F]	
Dew point stability	At const. conditions: < ±0.1 °C [±0.18 °F]	
Sample inlet temperature	**Max. +180 °C [356 °F]	
Sample inlet dew point	**Max. +80 °C [176 °F]	
Gas flow rate	**Max. 250 l/h	**Max. 2 x 150 l/h
Ambient temperature	+10 to +50 °C [50 to 122 °F]	
Max relative humidity	80 % at temperatures up to 50 °C, non-condensing	
Storage temperature	-20 to +60 °C [-4 to 140 °F]	
Total cooling capacity	40 W at 10 to 50 °C [50 °F to 122 °F] ambient temperature	
Ready for working	< 15 min	
Power consumption	Max. 200 VA (start up current at 240 V, 50-60 Hz = 2.5 A; at 120 V, 50-60 Hz = 4.5 A)	
Main power connection	240 V, 50-60 Hz/120 V, 50-60 Hz, -15/+10 %	
Electrical connections	Terminals: 2.5 mm ² , tightening torque for terminals X1 and X3: 0.5 to 0.6 N m, cable glands: 2 x M20 x 1.5, clamping range: 6-12 mm	
Status alarm	1 free configurable status alarm with 2 potential free change-over contacts, contact rating 250 V AC, 2 A; 500 VA; 50 W, see chapter 18, Figure 12 for under and over temperature settings	
Electrical safety	EN	EN 61010
		UL Std. No. 61010-1(3 Edition) and 61010.1-04 61010-2-011
Installation sites	The cooler is intended for indoor use. The maximum altitude is 2,000 m above sea level.	
Overvoltage category/ Pollution degree	II/2	
Refrigerant	R134a, content: 130 g [≈ 0.3 lb], max. operating pressure: 17 bar	
System of protection	IP20 (EN 60529)	
Case colour	RAL 9003	
Method of mounting	Wall-mount	
Dimensions (W x H x D)	270 x 270 x 316 mm [≈ 10.6" x 10.6" x 12.4"]	
Weight	Version: 240 V, 50-60 Hz: 12 kg [≈ 26.5 lbs] Version: 120 V, 50-60 Hz: 13.5 kg [≈ 29.8 lbs]	

* Option

**Maximum values in technical data must be rated in consideration of total cooling capacity at 25 °C [77 °F] ambient temperature and an outlet dew point of 5 °C [41 °F].

8.2 OPTIONS FOR BASIC COOLER ECM

Heat exchanger type	ECM-1G	ECM-1PV	ECM-1SS	ECM-2G	ECM-2PV	ECM-2SS
Part No.	93K0140	93K0170	93K0160	97K0100	97K0110	97K0115
Material of heat exchanger	Borosilicate glass	PVDF	Stainless steel 316Ti	Borosilicate glass	PVDF	Stainless steel 316Ti
Max. gas flow rate	250 NI/h	250 NI/h	250 NI/h	150 NI/h	150 NI/h	150 NI/h
Sample gas pressure abs.	Max. 2 bar (3 bar) ¹	Max. 3 bar	Max. 10 bar	Max. 2 bar (3 bar) ¹	Max. 3 bar	Max. 10 bar
Sample gas connection	GL18 for Ø 6 mm a.d. tube*	G1/4" i	G1/4" i or 1/4" NPT**	GL18 for Ø 6 mm a.d. tube*	Tube Ø 6 mm*	Tube Ø 6 mm*
Condensate connection	GL25 for Ø 12 mm tube* Ø 8 mm or Ø 10 mm**	G3/8" i	G3/8" i o. 3/8" NPT**	GL25 for Ø 12 mm tube* Ø 8 mm or Ø 10 mm**	G3/8" i	G3/8" i o. 3/8" NPT**
ΔP at max. flow	1 mbar	1 mbar	1 mbar	1 mbar	1 mbar	1 mbar
Stagnant space approx.	100 ml	100 ml	100 ml	40 ml	25 ml	30 ml

Peristaltic pump SR25.2	1 pc. incorporated in the cooler, compl. installed, part no. 01P9125; cooler weight plus 0.6 kg [≈ 1.32 lb] per pump ⚠ the sample gas pressure is limited to 2 bar absolute
-------------------------	--

* Standard, other version on request ¹ with GL connecting adapter

** Option

*** Maximum values in technical data must be rated in consideration of total cooling capacity at 25 °C [77 °F] ambient temperature and an outlet dew point of 5 °C [41 °F].

9 DESCRIPTION

Figure 3 shows the **ECM-2G** cooler unit.

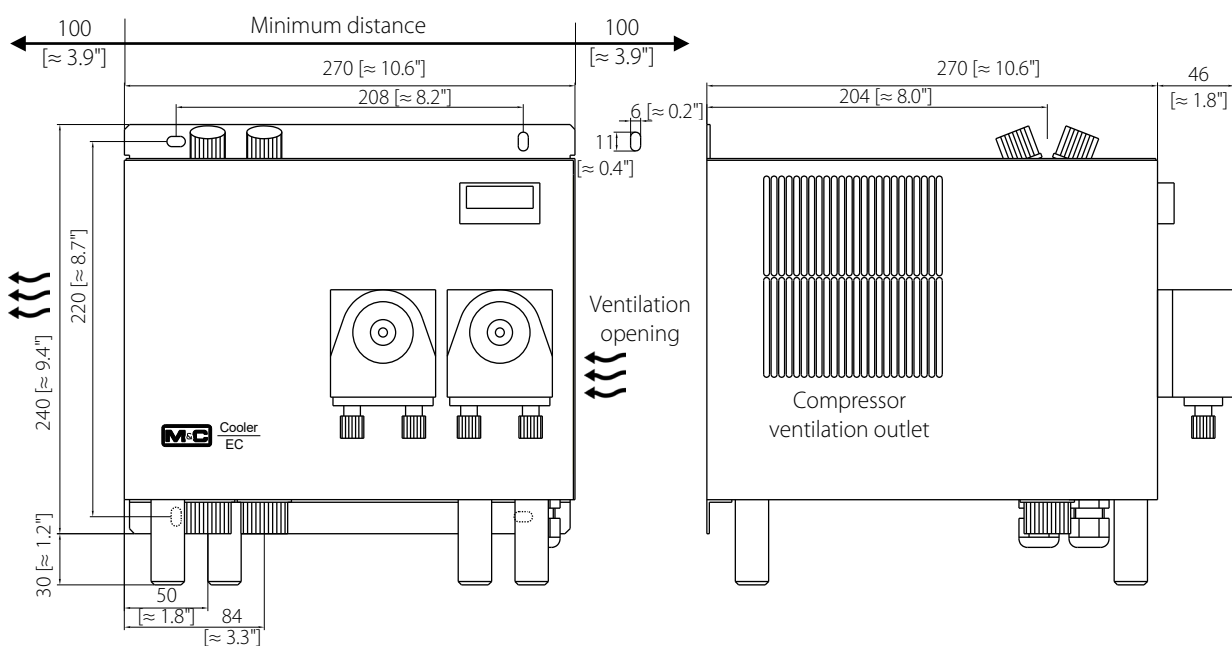

Dimensions in mm [Inch]

Figure 3 ECM-2G

The cooler **ECM** is equally suitable for wall installation. The depth of the housing of the cooler is 270 mm [\approx 10.6"] (316 mm [\approx 12.4"] with optional mounted peristaltic pumps).

On the upper side of the cooler housing you will see the cut outs for 1 or 2 heat exchangers. Sample gas enters and leaves the heat exchangers by the correspondingly connections on the upper part of the heat exchangers (see chapter 8. technical data).

The main power connector and the contact output for the status alarm can be connected at terminals X1 respectively X3 located behind the removable front panel of the **ECM** housing.

At the bottom of the housing the following connections are provided as standard:

- standard condensate outlets from the heat exchangers,
- cable bushings 2 x M20 x 1.5 clamping range 6-12 mm;

Condensate disposal is carried out in "negative pressure operation" (pump behind cooler) with peristaltic pumps of type **SR25.2** optionally installed in the cooler or, alternatively, externally using collecting vessels of type **TG/TK**. For "overpressure operation", condensate disposal is carried out through automatic float-type condensate traps e.g. type **AD**.

10 FUNCTION

The **M&C** gas cooler **ECM**, which was specially developed for analytical technology, operates according to the compressor cooling principle, and is equipped with a status alarm for safe continuous operation.

Up to 2 Jet-stream heat exchangers made of Borosilicate glass, PVDF or stainless steel are located in a heat-insulated cooling block. All the heat exchangers are easily accessible and are arranged in such a way that they can be removed very simply.

Figure 4 shows a schematic diagram of the functioning of the heat exchanger: The compressor cooler system has a heat-insulated cooling block at a constant temperature of +5 °C [41 °F]. The novel construction of the heat exchanger guarantees a very good pre-separation of condensate and for that reason an optimal drying of sample gas.

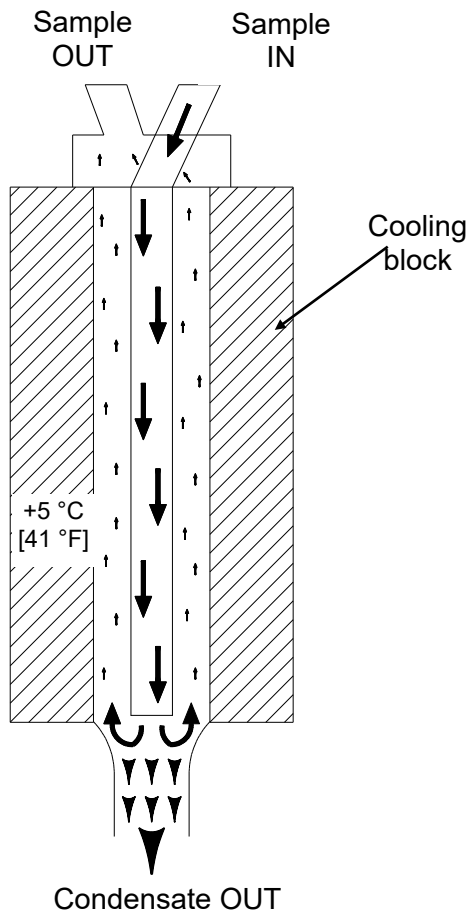

Figure 4 Schematic diagram of the heat exchanger function

11 RECEPTION AND STORAGE

The **ECM** gas cooler is a complete pre-installed unit.

Carefully inspect the **ECM** and any special accessories included with it immediately on arrival by removing them from the packing and checking for missing articles against the packing list! Check the items for any damage in transit and, if required, inform the shipping insurance company immediately of the damage found!



Note

The cooler must be stored in a weather protected frost-free area!

During transport and when in storage, the cooler must always be stood up with the transport feet positioned underneath so that the oil in the closed compressor circuit cannot run out of this compressor case.

If the cooler is transported on its back by mistake, it must be placed in the operating position for approx. 24 hours before it can be switched on!

12 INSTALLATION INSTRUCTIONS

The **ECM** cooler is suitable for wall mounting.



Note

The operating position for this cooler is exclusively vertical. This is the only way to ensure proper separation and removal of condensate in the heat exchangers. During transport and installation, the cooler must always be stood up with the transport feet positioned underneath so that the oil in the closed compressor circuit cannot run out of the compressor case.

The cooler should be kept away from sources of heat and well ventilated when installed, so that condensation from warmth will not occur and interfere with operation.

The minimum installation dimensions (figure 3) must be followed without fail. If the unit is installed in the open, the cooler must be installed in a housing that is frost-free in winter and adequately ventilated in summer. Avoid locating the unit in direct sunlight.

Unheated gas sample lines must be provided with slope up to the cooler. In that case pre-separation of the condensate is not required. Connect the heated sample line with sufficient thermal decoupling of min. 20 cm [≈ 7.9 ""] to the cooler!

13 HOSE CONNECTIONS

The connection for sample gas inlet and outlet are located on the upper part of the heat exchangers. For possible connectors see technical data (chapter 8).

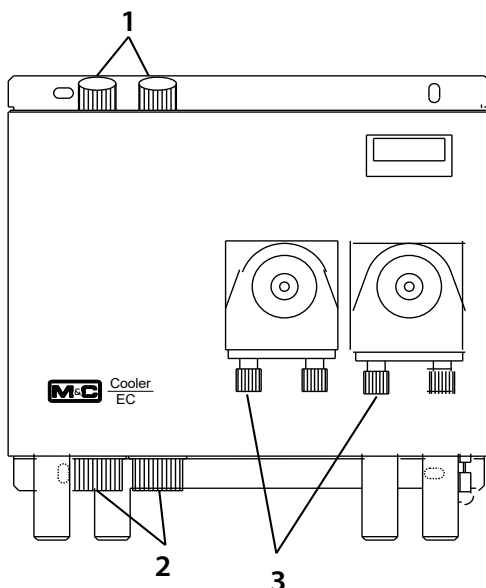

1 Gas inlet and outlet

3 Condensate outlet with optional mounted peristaltic pump

2 Condensate outlet

Figure 5 Gas and condensate connections

Correspondingly tube and hose connectors are optional available at **M&C**.

**Note**

Do not mix up the hose connections; the inlet and outlet connections of the heat exchangers are marked with arrows;
Ensure that the connections are sealed adequately;
To ensure free removal of the condensate, ensure that the listed diameters for the condensate removal lines are not reduced!

Ensure that the connections are sealed adequately by noting the following:

Borosilicate glass heat exchangers with connections GL18-6 respectively GL25-12 (standard)

- Before assembly, check the GL coupling rings to see if the PTFE/silicon locking rings have been damaged.
- The sealing rings should be installed with the PTFE side facing the medium.

PVDF- resp. stainless steel heat exchangers with G1/4" i resp. G3/8" i

- The correspondingly dimensioned tube respectively tube couplings with threaded connections have to be screwed in with PTFE thread sealing tape.
- To grant a functional and unproblematic mounting we recommend using union pieces with taper pipe thread type R according to DIN 2999/1 in connection with suitable sealing tape.

**Note**

When fixing the connectors in the PVDF respectively stainless steel heat exchanger hold up with a wrench at the pane of the bolt head!

Option: stainless steel heat exchanger with NPT

- The heat exchangers with NPT threaded connectors are marked with circulated notches.
- In order to ensure the tightness of the connections, the NPT thread must be screwed in with sealant or fixed with adhesive.

In the standard configuration, the tubes for removal of condensate are connected directly to the heat exchangers. These protrude with the GL25-12 tube connectors (standard, Borosilicate glass heat exchanger) respectively with G3/8" (standard) thread joint PVDF or stainless steel heat exchanger above the base plate of the cooler housing (figure 5).

Condensate removal is done by customer according to the type of operation with:

- peristaltic pump(s) type **SR25.2** implemented optionally in the cooler housing,
- external mounted condensate vessel(s) with manually emptying respectively,
- automatic float-type condensate traps type **AD** (only for over-pressure operation).

**Note**

When using the stainless steel heat exchanger with G3/8" condensate connection, the automatic condensate trap AD-SS can be mounted directly using a threaded adapter, part no. FF11000 (1/2" NPT to G3/8" i). This eliminates the otherwise necessary wall mounting and piping or tubing of the trap.

14 ELECTRICAL CONNECTIONS



Incorrect mains voltage can destroy the device: When connecting the device, make sure that the mains voltage is correct as specified on the type plate!



Attention must be paid to the requirements of IEC 364 (DIN VDE 0100) when setting high-power electrical units with nominal voltages of up to 1000 V, together with the associated standards and stipulations.

An easily accessible main switch with appropriate labeling must be provided externally.

The main circuit must be equipped with a slow-blow fuse of 10 A (over current protection); for electrical details see technical data (chapter 8).



Cooler versions with 120 V have a built-in transformer to generate an internal current of 240 V. That means, device internal live parts have a current of 240 V not 120 V.

Figure 6 shows the electrical connection options behind the front panel of the ECM housing:

A freely configurable status alarm with two potential-free changeover contacts is available for alarming the over or under temperature. An alarm is triggered with factory configuration (gas outlet dew point: 5 °C [41 °F], alarm window: 3 °C [5.4 °F], alarm hysteresis: 1 °C [1.8 °F]) within the limits < +1.5 °C [34.7 °F] (under temperature) and > +8.5 °C [47.3 °F] (over temperature). See also chapter 18, Figure 12.

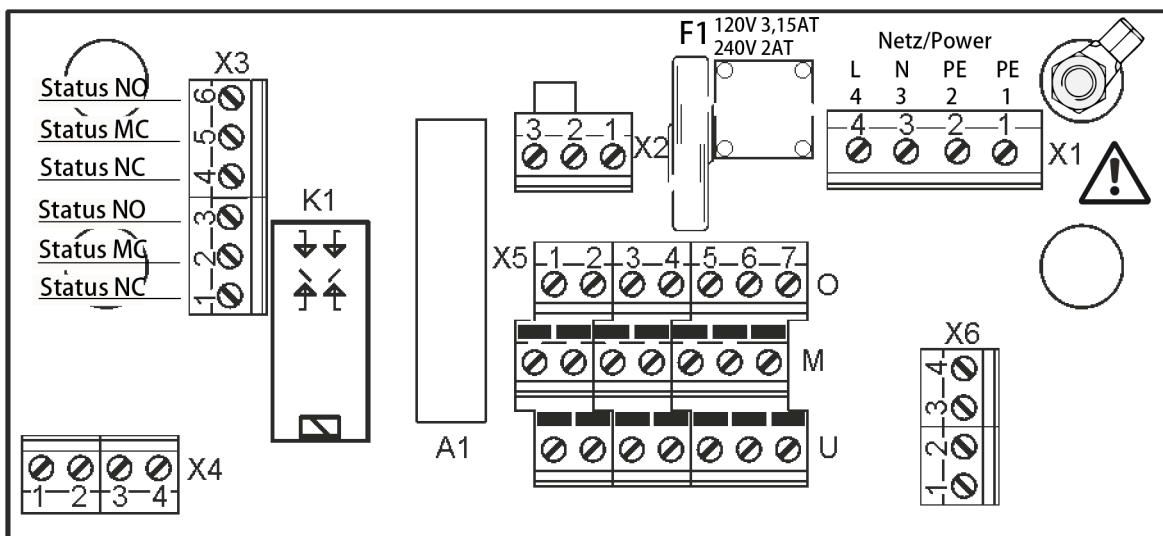

Figure 6 Electrical sockets alarm contact



Use only copper cables.

Use the following procedure to connect the mains line and the signal lines:

1. Loosen the screws (7 pieces) of the cooler top and remove the cooler top.
2. Pull the cable through the two cable glands with a clamping range of 6-12 mm in the bottom of the cooler.
3. Connect the mains cable (3 x 1 mm²/AWG 17) to X1 according to the wiring diagram. The tightening torque for terminal X1 is 0.5 to 0.6 N m.
4. Connect the status alarm cable (0.75 mm²/AWG 20) to terminal X3, number of cores 2 to 6, depending on the required contacts (two changeover contacts are available). The tightening torque for terminal X3 is 0.5 to 0.6 N m.
5. Assemble the housing parts in reverse order.

15 PREPARATIONS FOR COMMISSIONING

Before initial startup, all plant- and process-specific safety measures must be observed. It is mandatory for the operator to complete the enclosed risk assessment of the product.

The gas exposure risk must be assessed by the operator with regard to the hazards posed by process and calibration gas and the setup at the installation site (e.g. tubing, system cabinet/container/plant). If the risk assessment reveals increased exposure hazards, further measures are required.

A visible label must be attached to the installation site in accordance with the risk assessment provided by the operator.

16 START-UP

The thermo-hydraulic controlled cooling system of the **ECM** permits automatic start-up of the cooler.

The following description is valid for start-up of the gas cooler for an ambient temperature > +8 °C [46.4 °F].



Note

Before starting up the gas cooler, it must be placed in its operating position for at least two hours. The liquid inside the system may have been redistributed, and this could cause problems in operating.

The following steps should be carried out before initial start-up:

- Connect the cooler unit to the mains power supply; Check that the equipment is connected to the correct mains voltage, 120 V or 240 V, as shown on the type plate.
- Lead the status contact for status alarm to the measuring station;



Note

The status contacts must be connected to the external sample gas pump or to a valve in the sample gas line to protect the entire analysis system by immediately cutting off the gas supply in the event of error messages from the cooler!

17 CLOSING DOWN



Note

The location for the cooler must remain frost-free, even when the unit has been switched off!

If the cooler unit is putting out of action for a short time no particular measures need to be taken.

We recommend sweeping the cooler with inert gas or ambient air while the unit is putting out of action for a longer time.



Caution

Aggressive condensate is possible.



Wear protective glasses and proper protective clothing!

18 MAINTENANCE

The safety instructions specific to the plant and process are to be consulted prior to any maintenance work!



Danger

Dangerous voltage!

It is necessary to take the gas cooler off the mains before any assembly, maintenance and repair work is carried out!

The **ECM** cooler does not require any special maintenance intervals. The cooler is to be cleaned with compressed air according to the contamination level of the ambient air.

18.1 ADDING AND REPLACING THE HEAT EXCHANGERS

Removal of the heat exchangers may be necessary to carry out maintenance or repair work.

We recommend the following procedures and in this order for replacement of the heat exchangers:

1. Release the upper gas connections and lower condensate connections;
2. Pull the heat exchangers upwards with rotation out of the cooling block;

Replace the heat exchangers as follows:

1. Dry and clean the push-in opening in the aluminium cooling block with a cloth;
2. Smear the push-in opening with a thin and equal layer of thermal conductivity paste (part no. 90K0115);
3. Smear the heat exchangers with a thin and equal layer over the whole surface with thermal conductivity paste (part no. 90K0115) to ensure good conduction of heat. It is best to close off the condensate removal of the heat exchangers tube with adhesive tape to prevent any of the thermal conductivity paste from getting into the heat exchanger;
4. Lightly push the heat exchangers with rotation back into the push-in opening of the cooling block and press to the upper block;
5. Remove the adhesive tape and any surplus thermal conductivity paste;
6. Reconnect the hoses.



Note

Do not mix up the hose connections; gas outlet and gas inlet are marked with arrows!

Mounting the Borosilicate glass heat exchangers please notice:

1. Check the PTFE/Silicon locking rings for damage. In assembly, the locking rings must have the PTFE side facing the medium, otherwise the required degree of sealing cannot be guaranteed!
2. Hand-tighten the GL union nuts by turning them clockwise;

To ensure a safe connection of the sample gas respectively condensate tubes to the Borosilicate glass heat exchanger(s) we recommend the use of GL-couplings.

Please feel free to contact us, if you need any help choosing the right connectors or couplings.

18.2 CLEANING THE FINS OF THE CONDENSER

Dust on the fins of the condenser reduces the cooling capacity. Therefore it is necessary to clean the fins from time to time. The following steps are recommended:

1. Shut off the gas flow;
2. disconnect the cooler from the power supply;
3. disconnect sample gas inlet and outlet lines;
4. Loosen the screws of the cover part and remove the cover;
5. Carefully blow out the condenser fins with compressed air;
6. Carefully remount the cover part;
7. Connect sample gas lines



Note

Do not mix up the hose connections; the inlet and outlet connections of the heat exchangers are marked with arrows.

18.3 MAINTENANCE OF THE OPTIONAL MOUNTED PERISTALTIC PUMP(S), TYPE SR25.2

Before starting any maintenance work, make sure that any work done on the device is in compliance with all relevant regulations and standards.



Warning

Inhalation hazard possible, if using toxic or asphyxiant gases!



Purge peristaltic pump with inert gas or air before opening! If the pump is used for toxic gas or asphyxiant (oxygen-displacing) gas, it needs to be purged with inert gas or air before opening. Follow closely all relevant occupational safety regulations during operation.



Warning

Disconnect power supply before opening the device for access. Make sure that all external power supplies are disconnected.



Aggressive condensate possible!



Media residues in tubing!
Chemical burns caused by aggressive media possible!



Wear protective gloves and protective glasses!



Wear proper protective clothing!



Peristaltic pump is under pressure! Do not open housing!

A peristaltic pump might be part of a system, which is under pressure. Check pressure before opening peristaltic pump, and adjust pressure to atmospheric pressure.

Flexible tube, conveying belt, contact pulleys and contact springs are the only parts of the pump subject to wear. They are simple to change.



Note

If you send back the peristaltic pump to the M&C service for repair, please let us know what kind of condensate has been pumped.

Before sending the pump back clean all parts from dangerous or highly aggressive contaminants.

18.3.1 MOUNTING INSTRUCTIONS FOR SR25.2 PERISTALTIC PUMP (OPTIONAL)

Make sure to mount the pump to the front of the cooler with a minimum distance of 3.5 mm [≈ 0.14 "] and a maximum distance of 5.5 mm [≈ 0.22 "] between the pump motor and the front panel. The minimum distance avoids damage to the pump motor and the maximum distance prevents the motor shaft from getting loose.

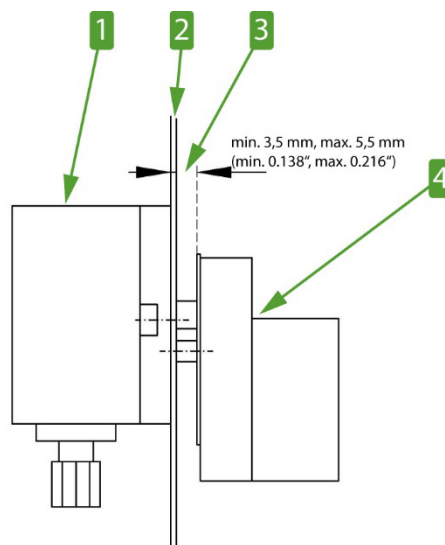

1 Pump head (outside the cooler housing)

2 Cooler front panel

3 Recommended mounting distance

4 Pump motor (inside the cooler housing)

Figure 7 SR25.2: Mounting distance between front panel and pump motor



Note

For mounting instructions, see the SR25.2 instruction manual. The manual is available on our website www.mc-techgroup.com.

18.3.2 CHANGING THE PUMP TUBING

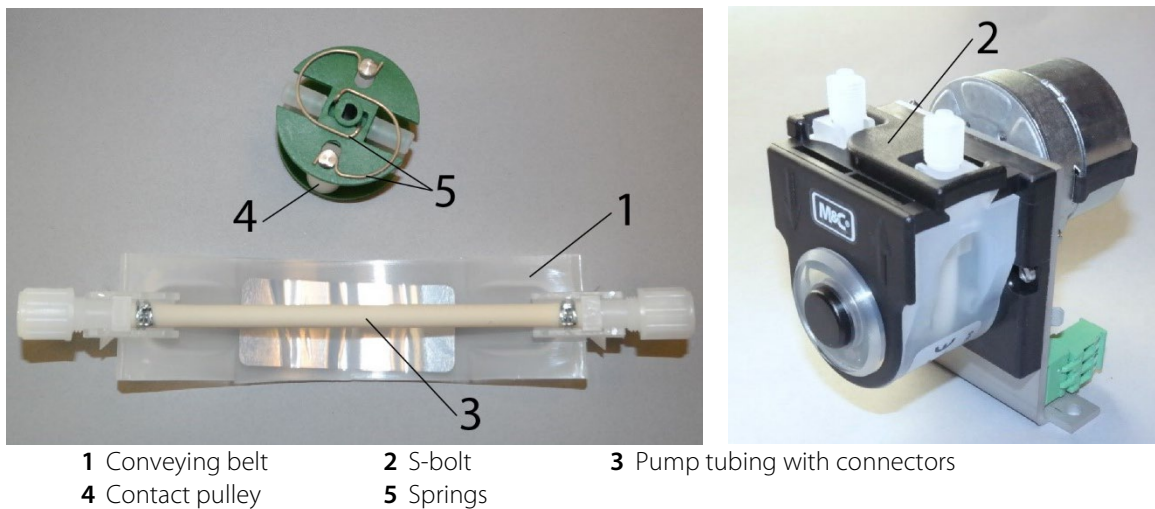

Figure 8 Changing the pump tubing

For changing the pump tubing please proceed as follows:

1. Unplug the pump from the mains voltage. The device needs to be voltage free.
2. Open tube connections at the pump;
3. Press conveying belt **1** at the recessed grips and turn S-bolt **2** clockwise up to limit stop;
4. Take away conveying belt **1** and remove the old pump tubing **3** from the guides by pulling on the tube connectors;
5. Press the two contact pulleys **4** and check whether the spring pressure is still sufficient, if not, the contact springs have to be changed (see chapter 16.3.3);
6. Put the new pump tubing **3** with the tube connectors into the guides of the conveying belt **1** ;



Warning

Only the usage of the original tubing set guarantees a proper functionality.
Never lubricate the tube.

Before mounting the pump check all parts for contaminations and clean if necessary.

7. Put the conveying belt **1** with the new tubing **3** into the dovetail guide of the pump body;
8. Press conveying belt at the recessed grips and simultaneously turn the S-bolt **2** anticlockwise until it snaps;
9. Switch on pump.

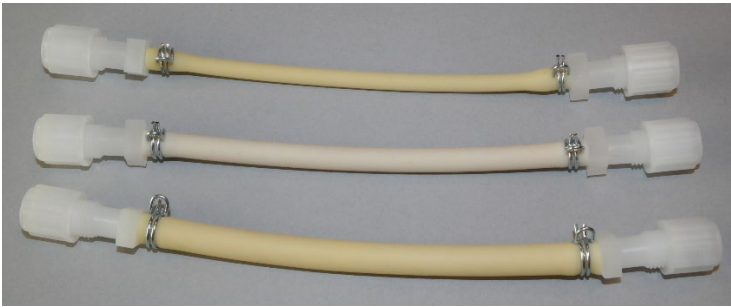

Figure 9 Different pump tube sizes

18.3.3 CHANGING CONTACT PULLEYS AND SPRINGS



Note

While mounting, make sure that the center of rotation and the driver are aligned.
Use genuine spare parts only!

Follow these instructions to change the contact pulley and springs:

1. Disconnect the peristaltic pump from power supply.
2. Unscrew nuts of the pump head (wrench size 5.5) **1**.

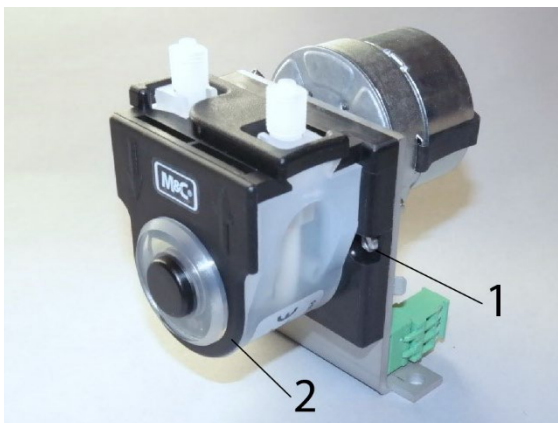

1 Pump head nuts
4 Groove

2 Pump head
5 Driver (roll carrier)

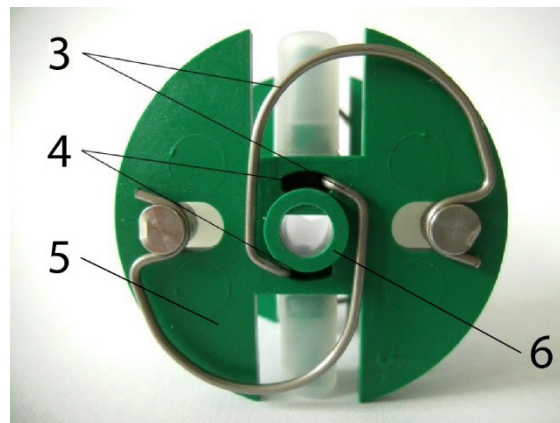

3 Springs
6 Collar of the shaft bore

Figure 10 Disassembly of pump head and driver

3. Remove the pump head **2** from the motor shaft.
4. Now the driver can be removed from the pump head and is ready for maintenance.
5. The removal of the springs (4 pcs.) **3** away from the driver is easily possible without the aid of any tools. For this take spring out of the groove **4** near to the shaft bore.

- Dismount roller axes and change contact pulleys. Take care that axes are not worn out by the springs and have damaged the dent at the axes front end. In case of abrasion the axes have to be changed (see Figure 11).

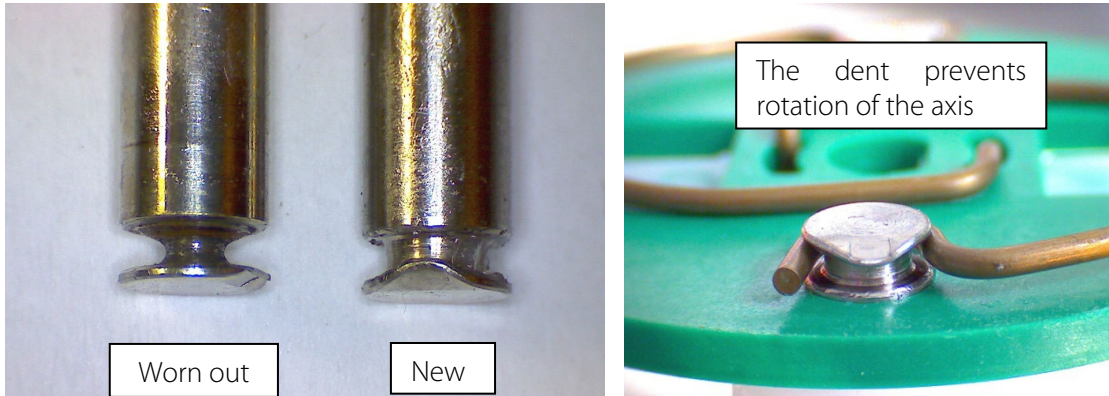

Figure 11 Check of axes and rolls



Note

The springs may come in different colorings. This is not a quality impairment. Make sure to use the right spring strength. This can be identified by the spring wire diameter.

The 'standard version for Novoprene pump tubing' (Part No. 90P1010) has a diameter of 1.1 mm and the 'reinforced version for FKM-, Acidflex®- or Masterflex®-tubing' (Part No. 90P1015) has a diameter of 1.2 mm.



Note

Two different types of springs are mounted inside the driver (right and left springs) for the first delivery.

When spare springs are ordered, for simplified storage, only one type will be delivered (right spring) which can be used for all four springs and will replace without any problems the initial springs. The replacement springs guarantee full functionality when all four springs are replaced.

- Make sure that contact pulleys move easily on the axis. After remounting the axis with contact pulley into the driver, the spring has to be mounted as shown as in Figure 11. Please pay attention to the alignment of the dent.

18.3.4 REASSEMBLY OF THE DRIVER

Reassemble the driver in reverse order:

1. Insert the roll carrier back into the pump head
2. Push the pump head with the roll carrier onto the motor shaft **2**.
3. Tighten the nuts of the pump head fastening (SW 5.5) **1**.



Note

While mounting, make sure that the center of rotation and the roll carrier (driver) are aligned.

Make sure that the collar of the shaft bore (see Figure 10) faces towards the front of the pump head while mounting the roll carrier.

Use genuine spare parts only!

18.3.5 CLEANING THE PUMP HEAD

When changing flexible tube or other parts, inspect all parts for dirt before assembling the pump head and clean them if necessary.

We recommend to clean the parts with a dry cloth. Solvent should not be used, because it can damage the plastics and synthetic rubber parts. Use oil-free compressed air to clean the parts if available.



Aggressive condensate possible!

Media residues in tubing!

Chemical burns caused by aggressive media possible!



Wear protective gloves and protective glasses!



Wear proper protective clothing!

18.3.6 REPAIR INFORMATION FOR INTEGRATED PERISTALTIC PUMP TYPE SR25.2 (OPTIONAL)



Note

When sending the peristaltic pump to M&C customer service for repair, please indicate the type of medium pumped. Before shipping the pump, please remove hazardous or aggressive contaminations from all parts of the pump!

19 OPERATING OF THE BUILT-IN ELECTRONIC TEMPERATURE CONTROLLER

New electronic temperature controllers were installed in the housing of the ECM cooler effective April 2022 and June 2023.

All built-in temperature controllers are factory set to the following values: Gas outlet dew point 5 °C, alarm window 3 °C and hysteresis 1 °C.

Figure 12 shows the hysteresis behavior of the status alarm at factory settings. The status alarm of the temperature controller is activated (alarm ON) and deactivated (alarm OFF) depending on the temperature, following the hysteresis.

When the cooler is switched on, the temperature is cooled down starting from the ambient temperature, which means that the status alarm is activated: Alarm ON. Figure 12 shows that the alarm remains active until the temperature of 7.5 °C is reached. The status alarm follows the hysteresis and is set to Alarm OFF at 7.5 °C. If the temperature remains within the range of 1.5 to 8.5 °C, the status alarm will stay at Alarm OFF. If the temperature changes beyond these limits, the temperature controller follows the hysteresis and sets the status alarm back to Alarm ON at a temperature below 1.5 °C or above 8.5 °C.

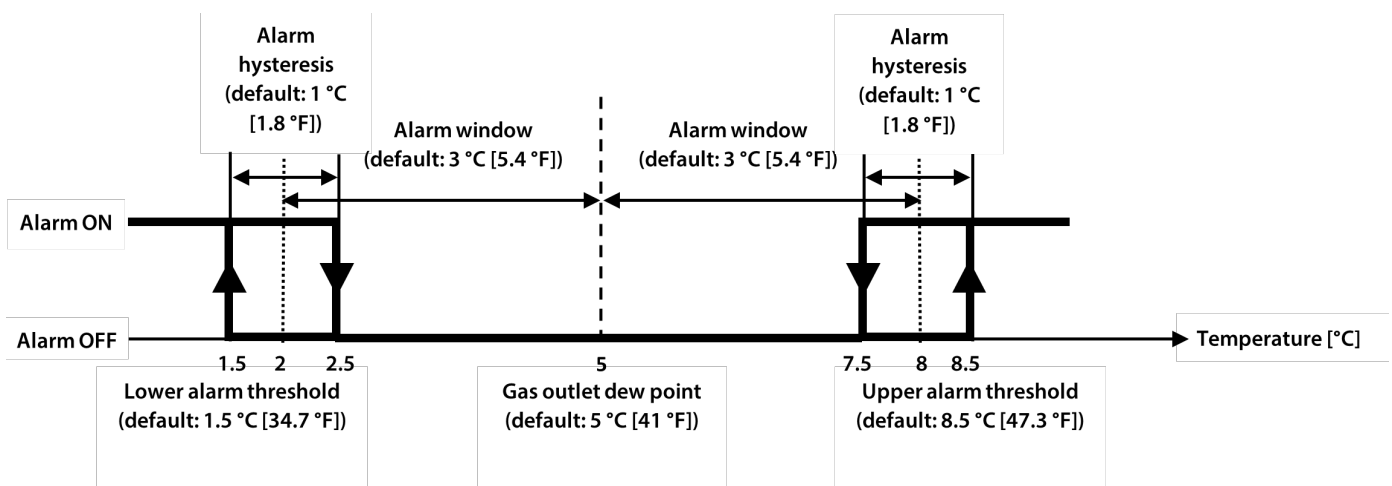

Figure 12 Hysteresis behavior of the status alarm at factory settings

19.1 TEMPERATURE CONTROLLER VERSION UNTIL MARCH 2022

In normal operation the display of the temperature controller shows the actual cooling temperature. Figure 13 shows the front view of the temperature controller.



Figure 13 Front view of the temperature controller version until 03.2022

19.1.1 CHANGING THE SET VALUE

To change the set value the P-button has to be pushed in for < 2 sec. The default value of 5 °C [41 °F] appears. With the two arrow buttons the value can be changed. This value should not be adjusted lower than +1 °C [33.8 °F], because otherwise the heat exchanger will freeze up. Is the value adjusted higher than the ambient temperature the cooler will not work.

19.2 TEMPERATURE CONTROLLER VERSION STARTING APRIL 2022

In normal operation, the display of the temperature controller shows the current cooling temperature in the upper line. In the bottom line, the adjusted set point is displayed.



Figure 14 Front view of the temperature controller version starting 04.2022

19.2.1 CHANGING THE SET VALUE

Pressing the Δ or ∇ key once causes the set setpoint to start flashing in the bottom line.

Now the setpoint can be increased or reduced using the Δ or ∇ keys. However, the value should not be set lower than +1 °C [33.8 °F], otherwise the heat exchanger is likely to freeze.

The change can be cancelled at any time with the \curvearrowright key. The change is only accepted with the Menu/OK key.

19.3 TEMPERATURE CONTROLLER VERSION STARTING 09.2023

In normal operation, the display shows the measured temperature (temperature view). The ESC key and the arrow keys (UP and DOWN) are disabled in this view. Figure 15 shows the front view of the temperature controller.



Figure 15 Front view of the temperature controller version starting 09.2023

While you tap the OK key, the set setpoint value is displayed. The factory setting of the setpoint is "5.00". After releasing the key, the display immediately returns to the temperature view. The setpoint is only visible when the key is tapped.

19.3.1 CHANGING THE SETPOINT

The temperature controller needs to be unlocked, before changing the setpoint. To unlock the device, first press the OK key for about 3 seconds. The display changes to a flashing "000".

Then enter the PIN code "017" with the arrow keys and confirm the entry with OK. The display jumps back to the temperature view.

Now the temperature controller is unlocked. Again, press the OK key for about 3 seconds. The display changes to the setpoint view and the display is flashing.

While the display is flashing, the setpoint can be adjusted with the arrow keys. With OK the new setpoint is accepted. With ESC the current changes are discarded. In both cases, the display jumps back to the normal temperature display after pressing.



Note

If you hold the OK key too long, you will enter the configuration menu. This menu shows a "C", followed by two digits on the display. To return to the temperature view tap on the ESC key.

20 TROUBLE SHOOTING

The following table shows a list of possible errors and instructions how to check and to repair them (this is not valid for the starting-up period of the cooler).

Error	Possible reason	Check/Repair
Condensate in the gas outlet	Ambient temperature < 5 °C [41 °F] Cooler overloaded Peristaltic pump doesn't work Tube of the peristaltic pump defective Cooling capacity too low (cooler is not overloaded) Motor protection switch released	Heat up the components downstream; Keep the operational data (chapter 8); Change peristaltic pump; Change the tubing (chapter 18.3.2); Clean the fins of the condenser (chapter 18.2); Check the vent; Check the safety distance to other heated components; Secure sufficient ventilation; Thermal load caused by the sample gas resp. ambient is too high; Clean the fins of the condenser (chapter 18.2); Keep the operational data (chapter 8); Let the cooler cool down before restarting it;
Gas flow blocks up reading	Contamination of the sample gas way	Optimize the dust pre-separation upstream the cooler; Clean the gas ways and the cooling system;
Wrong temperature	Temperature sensor defective Temperature controller defective Circuit of cooling agent leaky	Check the PT100-sensor; Check the temperature controller; Send the cooler for repair;
Cooler break-down	Power supply interrupted	Check the power supply and reconnect;  Pay attention to the relevant safety instructions!



Error	Possible reason	Check/Repair
Compressor does not work	Compressor defective; Motor protection switch defective	Send the cooler for repair;

21 PROPER DISPOSAL OF THE DEVICE

At the end of the life cycle of our products, it is important to take care of the appropriate disposal of obsolete electrical and non-electrical devices. To help protect our environment, please follow the rules and regulations of your country regarding recycling and waste management.

22 SPARE PARTS LIST

Wear, tear and replacement part requirements depend on specific operating conditions.
The recommended quantities are based on experience and they are not binding.

Electric gas cooler ECM					
(C) Consumable parts					
(R) Recommended spare parts					
(S) Spare parts					
					Recommended quantity being in operation [years]
Part No.	Indication	C/R/S	1	2	3
93K0140	ECP-3000 G Jet-Stream heat exchanger material: Borosilicate glass connections gas: GL18-6 mm condensate: GL 25-12 mm	R	1	1	1
93K0160	ECP-3000 SS Jet-Stream heat exchanger material: SS 316 connections gas: G 1/4" i condensate: G 3/8" i	R	1	1	1
93K0170	ECP-3000 PV Jet-Stream heat exchanger material: PVDF (Polyvinylidenfluorid) connections gas: G 1/4"i condensate: G 3/8" i	R	1	1	1
97K0100	ECM-2G Jet-Stream heat exchanger material: Borosilicate glass connections gas: GL18-6 mm condensate: GL 25-12 mm	R	1	1	1
97K0110	ECM-2PV Jet-Stream heat exchanger material: PVDF (Polyvinylidenfluorid) connections gas: 6mm tube condensate: G 3/8" i	R	1	1	1
97K0115	ECM-2SS Jet-Stream heat exchanger material: SS 316 connections gas: 6 mm tube condensate: G 3/8" i	R	1	1	1
90K0115	EC-thermal conductivity paste 50 g for -40 to 140 °C [-40 to 284 °F]	R	1	1	2
90K0035	Fan ECP 240 V, 50-60 Hz	C	-	-	1
93K0040X	PT-100 temperature sensor for ECM	C	-	-	1
90K7005	Cooling unit, complete with compressor, vaporiser and condensor for ECM cooling medium: R134A, power: 240 V, 50-60 Hz	R	-	-	-
97K0010	ECM transformer 120 V/240 V, 230 VA	R	-	-	-
01B8360	Electronic PID-temperature controller for ECM version until 03.2022	T	-	-	1
01B8370	Electronic PID-temperature controller for ECM version starting 04.2022	T	-	-	1
04E1000	Electronic PID-temperature controller for ECM version starting 09.2023	T	-	-	1

Peristaltic pump SR25.2					
(C) Consumable parts					
(R) Recommended spare parts					
(S) Spare parts					
		Recommended quantity being in operation [years]			
Part No.	Indication (see figure 8 for numbering in bold)	C/R/S	1	2	3
90P1007	Tubing set 3 SR25 with PVDF-tube connectors 4/6 mm, standard	C	1	2	4
90P1020	Driver SR25, complete	S	-	1	1
90P1010	1 set (4 pcs) contact springs 5 SR25 for driver	R	1	2	2
90P1045	Contact pulleys SR25 PVDF 4 for driver	S	2	4	4
90P1050	Conveying belt SR25 1	S	-	1	2
90P1025	S-bolt 2 SR25	S	-	-	1
01P1300	Peristaltic pump SR25.2, complete 240 V, 50-60 Hz/120 V, 50-60 Hz	R	-	-	1
90P1031	Heat peristaltic pump SR25, complete without tube set, motor and gears	S	-	-	1

23 RISK ASSESSMENT

The risk assessment provided in this chapter is intended for all work activities on the product. The hazards can occur in the work steps of assembly, commissioning, maintenance, disassembly and in the event of a product fault. During normal operation, the product is protected by a system cabinet or appropriate covers.

Only qualified personnel is permitted to perform the work. The following minimum knowledge is required for the work:

- Employee instruction provided in process engineering
- Employee instruction provided in electrical engineering
- Detailed knowledge of the instruction manual and the applicable safety regulations

The product complies with the current regulations according to state-of-the-art science and technology. Nevertheless, not all sources of danger can be eliminated while observing technical protective measures. Therefore, the following risk assessment and the description of exposure hazards refer to the work steps mentioned above.

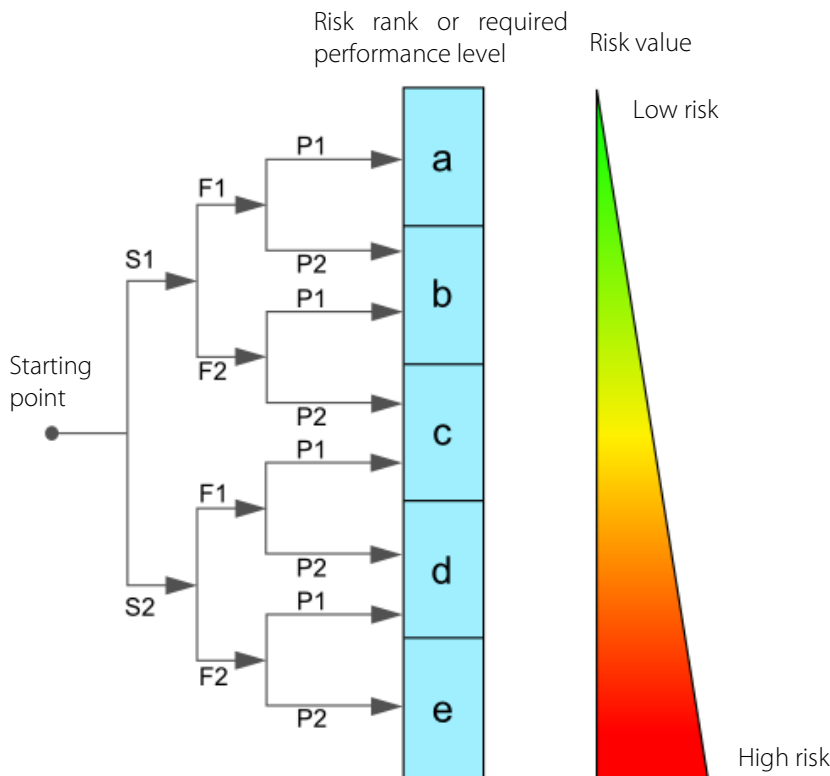

Severity of injury:

S1 = 1 = minor (reversible injury)
 S2 = 2 = serious (irreversible injury, death)

Frequency and duration:

F1 = 1 = infrequent or short exposure to hazard
 F2 = 2 = frequent (more than once per hour/shift)

Possibility of preventing or limiting the damage

P1 = 1 = possible
 P2 = 2 = hardly possible

Figure 16 Overview risk assessment



Aggressive condensate possible

Risk rank group A

Chemical burns due to aggressive media possible!
 This applies to all liquids in vessels and in the product.
 In general, for electrical and mechanical work on the product, wear personal protective equipment (PPE) in accordance with the risk assessment.



Caution risk of being crushed by rotating parts

Risk rank - group A

The product contains rotating parts. Do not open covers until the device has been switched off.



Caution glass

Risk rank - group A

The product contains glass components. In general, for electrical and mechanical work on the product, wear personal protective equipment (PPE) in accordance with the risk assessment.



Caution hot surfaces

Risk rank group A

The temperature inside the product can be higher than $> 60\text{ }^{\circ}\text{C}$.

The hot parts are shielded by mechanical devices. Before opening the products, they must be disconnected from the power supply and a cooling time of more than > 20 minutes must be observed. In general, for electrical and mechanical work on the product, wear personal protective equipment (PPE) in accordance with the risk assessment.



Caution electric shock

Risk rank group C

When installing high-power systems with nominal voltages of up to 1000 V, the requirements of VDE 0100 and their relevant standards and regulations must be observed!

This also applies to any connected alarm and control circuits. Before opening the products, they must always be disconnected from the power supply.



Gas hazard

Risk rank group A-B-C

The hazard potential mainly depends on the gas to be extracted.

If toxic gases, oxygen displacing or explosive gases are conveyed with the product, an additional risk assessment by the operator is mandatory.

In principle, the gas paths must be purged with inert gas or air before opening the gas-carrying parts.

The escape of potentially harmful gas from the open process connections must be prevented.

The relevant safety regulations must be observed for the media to be conveyed. If necessary, flush the gas-carrying parts with a suitable inert gas. In the event of a gas leakage, the product may only be opened with suitable PPE or with a monitoring system. Furthermore, the work safety regulations of the operator must be observed.



Caution crushing hazard

Risk rank group A

The work must be performed by trained personnel only.

This applies to products weighing less than $< 40 \text{ kg}$ [$\approx 88.2 \text{ lbs}$]:

The product can be transported by 1 to 2 person(s). The instructions for appropriate personal protective equipment (PPE) must be observed.

The weight specifications are contained in the technical data of this product.

Furthermore, the work safety regulations of the operator must be observed.

24 APPENDIX

- Dependency of gas outlet dew point at a gas inlet point of $60 \text{ }^\circ\text{C}$ [$140 \text{ }^\circ\text{F}$]
- Circuit diagram ECM
- Compressor connection
- Certificate of compliance



Further product documentation can be seen and downloaded from our home page:

www.mc-techgroup.com

- Data sheets:
 - Threaded couplings for 'GL' glass connections
 - Automatic condensate trap AD-SS
 - Automatic condensate trap AD-P
 - Condensate vessel TG, TK
- Instruction manual peristaltic pump SR25.2

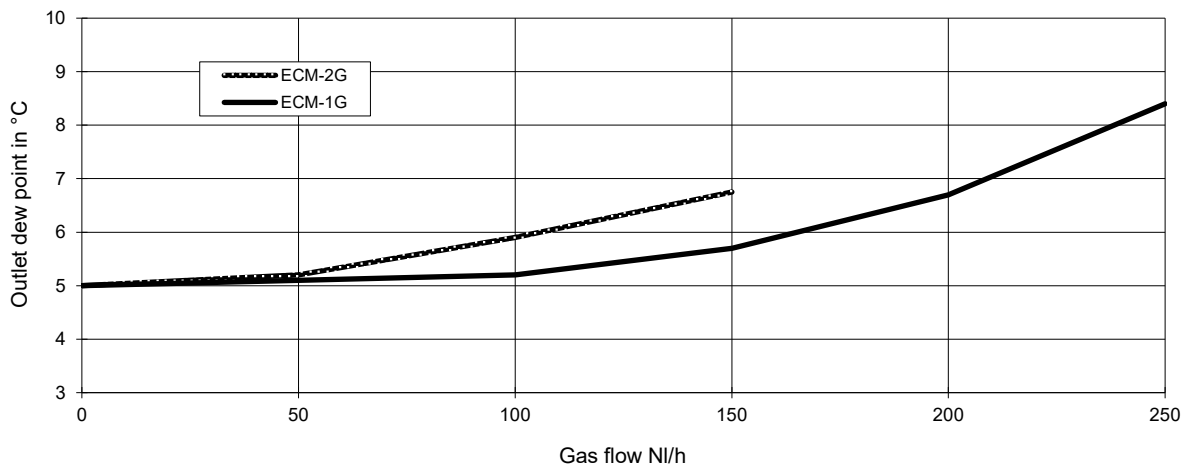

Figure 17 Dependency of gas outlet dew point at a gas inlet point of $60 \text{ }^\circ\text{C}$ [$140 \text{ }^\circ\text{F}$]

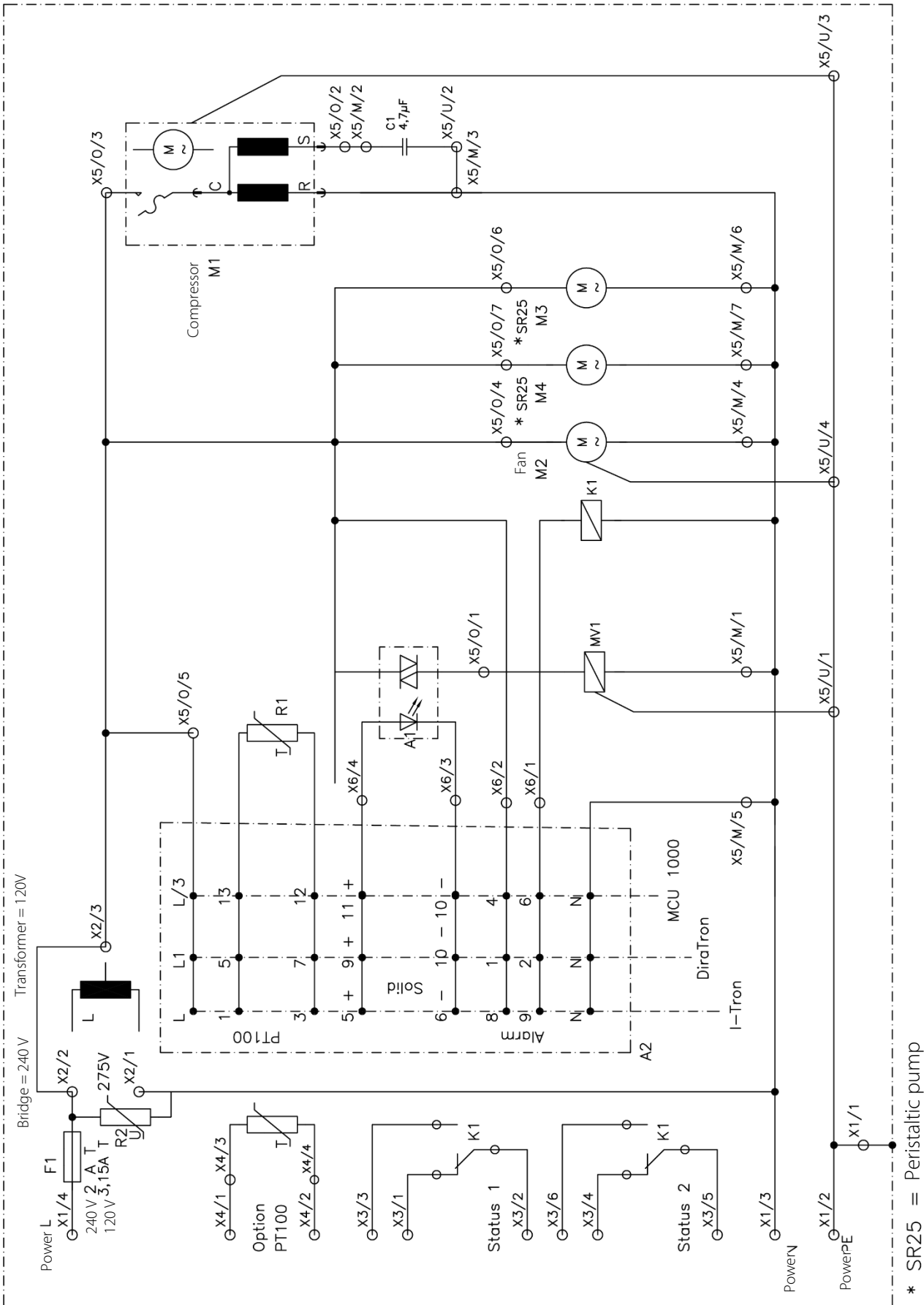

Figure 18 Circuit diagram ECM

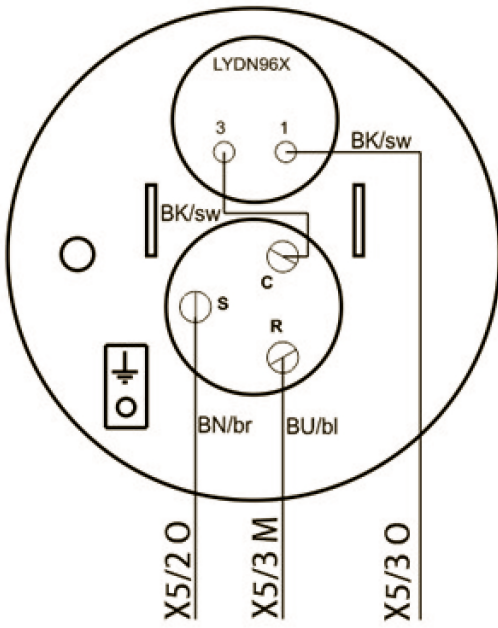

Figure 19 ECM compressor connection



Certificate of Compliance

Certificate:	1830702	Master Contract:	222408
Project:	80211328	Date Issued:	2024-05-15
Issued to:	M&C TechGroup Germany GmbH Rehhecke 96 Ratingen, North Rhine-Westphalia 40885 Germany Attention: Ralf Krauskopf		

The products listed below are eligible to bear the CSA Mark shown with adjacent indicators 'C' and 'US' for Canada and US or with adjacent indicator 'US' for US only or without either indicator for Canada only.



Issued by: *Andreas Kohler*
Andreas Kohler

PRODUCTS

Class 8721 06 ELECTRICAL LABORATORY EQUIPMENT - Electrical Laboratory Equipment
 Class 8721 86 ELECTRICAL LABORATORY EQUIPMENT - Certified to US Standards

Electric gas cooler (component type)

Model(s)
ECM, ECM-ExII

Rated 120 V or 240 V, 50/60 Hz, 200 VA; Permanently connected, Equipment Class I, Continuous Operation, Pollution Degree 2; Overvoltage Category II; Altitude 2000m; Operating Temperature +10 °C to 50 °C, Operating Humidity 80% up to 50°C (non-condensing), Refrigerant R134a, Refrigerant fill weight 130g.

Conditions of Acceptability:

1. The equipment is to be installed by trained personnel in accordance with the accompanying documentation.



Certificate: 1830702

Master Contract: 222408

Project: 80211328

Date Issued: 2024-05-15

-
2. Device shall be provided with a disconnecting means in the End-Use Application. The disconnecting means shall disconnect all current-carrying conductors. This switch or circuit breaker shall be suitable located and easily accessible. The switch or circuit-breaker shall be marked as disconnecting device for the device or the End-Use Application.

APPLICABLE REQUIREMENTS

CSA C22.2 No. 61010-1-12, UPD1:2015, UPD2:2016, AMD1:2018 - Safety requirements for electrical equipment for measurement, control, and laboratory use — Part 1: General requirements

CSA C22.2 No. 61010-2-011:19 - Safety requirements for electrical equipment for measurement, control, and laboratory use — Part 2-011: Particular requirements for refrigerating equipment - second edition

UL 61010-1 3rd ed (Rev. Nov 21, 2018) - UL Standard for Safety Electrical Equipment For Measurement, Control, and Laboratory Use; Part 1: General Requirements - Third Edition; Including Revisions through November 21, 2018

UL 61010-2-011 2nd Edition (2021) - UL Standard for Safety Requirements for Electrical Equipment for Measurement, Control, and Laboratory Use – Part 011: Particular Requirements for Refrigerating Equipment - Second Edition



Certificate: 1830702

Project: 80211328

Master Contract: 222408

Date Issued: 2024-05-15

Notes:

Products certified under Class(es) C872106, C872186 have been certified under CSA's ISO/IEC 17065 accreditation with the Standards Council of Canada (SCC). www.scc.ca





Supplement to Certificate of Compliance

Certificate: 1830702

Master Contract: 222408

The products listed, including the latest revision described below, are eligible to be marked in accordance with the referenced Certificate.

Product Certification History

Project	Date	Description
80211328	2024-05-15	Update of cCSAus Certificate 1830702 Rev. 80179434 of Electric gas cooler (component type), Model ECM, ECM-ExII to include change to humidity rating and alternate fan M2 to LOCC without additional testing.
80179434	2023-08-31	Update of cCSAus Certificate 1830702 Rev. 80121582 for Electric Gas Cooler, Models ECM, ECM-ExII, to add new temperature controller MCU 1000 without additional testing according to 61010-1 3rd Edition + AMD1. Results from PN 80161076 are partially considered.
80121582	2022-12-14	Update of cCSAus Certificate 1830702 Rev. 2492050 for Electric Gas Cooler, Models ECM, ECM-ExII, to add new temperature controller and update to 61010-1 3rd Edition + AMD1 including 61010-2-011
2492050	2012-12-19	Update to Report 1830702 to add alternative approved critical components: Fuse holder, fuse F1 and ventilator M2. No additional tests required
1830702	2006-09-08	Original cCSAus Certification of Electric Gas Cooler models ECM, ECM- ExII.