

# Flow Alarm Sensors Series FA<sup>®</sup> FA -1/2/3,bi

# Electronic Controllers Series FA<sup>®</sup> FA-1.1, FA-1.4

# Pre-Amplifier K-FA..

Instruction Manual  
Version 1.01.01

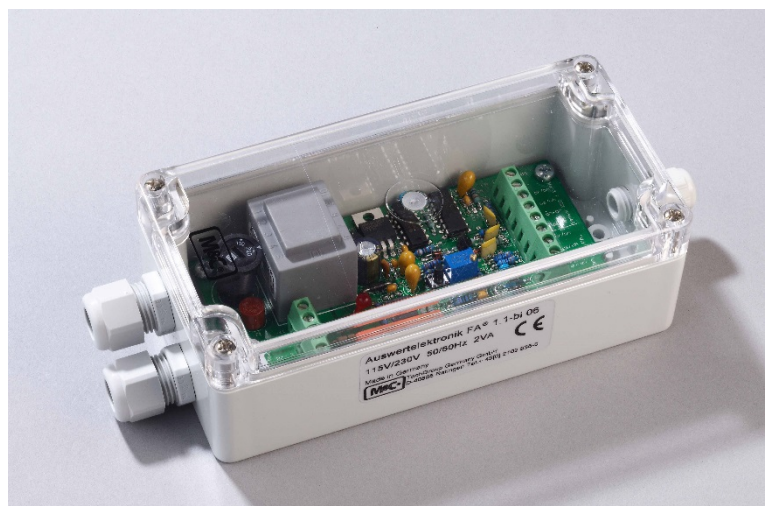
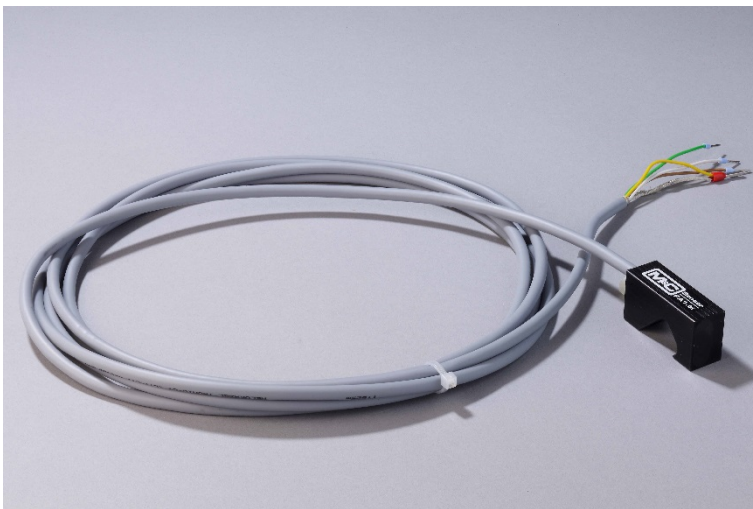

**Dear customer,**

Thank you for buying our product. In this instruction manual you will find all necessary information about this M&C product. The information in the instruction manual is fast and easy to find, so you can start using your M&C product right after you have read the manual.

If you have any question regarding the product or the application, please don't hesitate to contact M&C or your M&C authorized distributor. You will find all the addresses in the appendix of this manual.

For additional information about our products and our company, please go to M&C's website [www.mc-techgroup.com](http://www.mc-techgroup.com). There you will find the data sheets and manuals of all our products in German and English.

This Operating Manual does not claim completeness and may be subject to technical modifications.

© 02/2020 **M&C TechGroup** Germany **GmbH**. Reproduction of this document or its content is not allowed without permission from **M&C**. **FA**® is a registered trade mark.

Version: 1.01.01

## Contents

<b>1</b>	<b>General information</b> .....	<b>4</b>
<b>2</b>	<b>Declaration of conformity</b> .....	<b>4</b>
<b>3</b>	<b>Safety instructions</b> .....	<b>5</b>
<b>4</b>	<b>Warranty</b> .....	<b>5</b>
<b>5</b>	<b>Used terms and signal indications</b> .....	<b>6</b>
<b>6</b>	<b>Introduction</b> .....	<b>7</b>
6.1	Patented flow alarm sensor.....	7
<b>7</b>	<b>Application</b> .....	<b>7</b>
<b>8</b>	<b>Technical data</b> .....	<b>8</b>
<b>9</b>	<b>Description</b> .....	<b>9</b>
<b>10</b>	<b>Receipt of goods and storage</b> .....	<b>11</b>
<b>11</b>	<b>Installation instructions</b> .....	<b>11</b>
<b>12</b>	<b>Mounting</b> .....	<b>12</b>
<b>13</b>	<b>Electrical connection</b> .....	<b>12</b>
13.1	Electronic controller FA-1.1 .....	13
13.2	Electronic controller FA-1.4.....	14
13.3	Pre-amplifier K-FA .....	15
<b>14</b>	<b>Starting</b> .....	<b>17</b>
14.1	Sensitivity Adjustment for electronic controllers FA1.1 and FA1.4 .....	17
14.2	Sensitivity adjustment for use of pre-amplifier K-FA.....	18
14.3	Adjustment of the delay time .....	18
<b>15</b>	<b>Closing down</b> .....	<b>19</b>
<b>16</b>	<b>Maintenance and Repair</b> .....	<b>19</b>
<b>17</b>	<b>List of spare parts</b> .....	<b>20</b>
<b>18</b>	<b>Annexe</b> .....	<b>20</b>

## List of illustrations

Figure 1	FA-1/2/3bi on measuring glass with bi-stable or mono-stable function .....	11
Figure 2	Electrical connection and dimensions FA-1.1.....	13
Figure 3	Electrical connection and dimensions FA-1.4.....	14
Figure 4	Assembly plan of the FA-1.4.....	15
Figure 5	Electrical connection K-FA.....	16
Figure 6	Circuit diagram of the electronic controller FA1.1, 115/230 V.....	21
Figure 7	Circuit diagram of the electronic controller FA1.1, 24 V AC.....	22
Figure 8	Circuit diagram of the electronic controller FA1.4, 115/230 V.....	23
Figure 9	Circuit diagram of the electronic controller FA1.4, 24 V AC/DC.....	24
Figure 10	Circuit diagram of the electronic controller K-FA (-H), 115/230 V .....	25

## Head Office

**M&C TechGroup** Germany GmbH ♦ Rehhecke 79 ♦ 40885 Ratingen ♦ Germany  
Telephone: 02102 / 935 - 0  
Fax: 02102 / 935 - 111  
E - mail: [info@mc-techgroup.com](mailto:info@mc-techgroup.com)  
[www.mc-techgroup.com](http://www.mc-techgroup.com)

## 1 GENERAL INFORMATION

The product described in this operating manual has been examined before delivery and left our works in perfect condition related to safety regulations. In order to keep this condition and to guarantee a safe operation, it is important to heed the notes and prescriptions made in this operating manual. Furthermore, attention must be paid to appropriate transportation, correct storage, as well as professional installation and maintenance work.

All necessary information a skilled staff will need for appropriate use of this product are given in this operating manual.

## 2 DECLARATION OF CONFORMITY



The product described in this operating manual complies with the following EU directives:

### EMC-Instruction

The requirements of the EU directive 2014/30/EU "Electromagnetic compatibility" are met.

### Low Voltage Directive

The requirement of the EU directive 2014/35/EU "Low Voltage Directive" are met.  
The compliance with this EU directive has been examined according to DIN EN 61010.

### Declaration of conformity

The EU Declaration of conformity can be downloaded from the **M&C** homepage or directly requested from **M&C**.

### 3 SAFETY INSTRUCTIONS

**Observe the following basic safety precautions when installing, commissioning and operating the device:**

Read the operating instructions before putting the device into operation and using it. The instructions and warnings given in the operating instructions must be followed.

Work on electrotechnical devices may only be carried out by qualified personnel in accordance with the currently valid regulations.

The requirements of VDE 0100 must be observed when installing power installations with rated voltages up to 1000V as well as your relevant standards and regulations.

When connecting the device, make sure that the mains voltage is correct as specified on the nameplate.

Protection against contact with impermissibly high electrical voltages:  
Before opening the device, it must be disconnected from the power supply. This also applies to any external control circuits connected.

Only use the device in the permitted temperature and pressure ranges.

Ensure that the unit is installed in a weatherproof place. Do not expose the unit directly to rain or liquids.

The devices described in these operating instructions must not be operated in potentially explosive atmospheres.

Installation, maintenance, inspection and possible repairs may only be carried out by authorized persons in compliance with the relevant regulations

### 4 WARRANTY

If the equipment fails, please contact **M&C** directly or else go via your appointed **M&C** dealer. We offer a one year warranty as of the day of delivery as per our normal terms and conditions of sale and assuming technically correct operation of the device. Consumables are hereby excluded. The terms of the warranty cover repair at the factory at no cost or the replacement at no cost of the equipment free ex user location. Reshipments must be sent in a sufficient and proper protective packaging.

## 5 USED TERMS AND SIGNAL INDICATIONS



**DANGER!**

This means that death, severe physical injuries and/or important material damages **will occur** in case the respective safety measures are not fulfilled.



**WARNING!**

This means that death, severe physical injuries and/or important material damages **may occur** in case the respective safety measures are not fulfilled.



**CAUTION!**

This means that minor physical injuries **may occur** in case the respective safety measures are not fulfilled.

**CAUTION!**

Without the warning triangle means that a material damage may occur in case the respective safety measures are not met.

**NOTICE!**

This means that an unintentional situation or an unintentional status may occur in case the respective notice is not respected.



**NOTE!**

These are important information about the product or parts of the operating manual which require user's attention.

**QUALIFIED PERSONNEL**

These are persons with necessary qualification who are familiar with installation, use and maintenance of the product.



High voltages!

Protect yourself and others against damages which might be caused by high voltages.

## 6 INTRODUCTION

The flow alarm units **FA...** are used for monitoring failures of sample gas or test gas in analysing equipment or analyse systems.

The patented **M&C** flow alarm sensor **FA-1/2/3bi** can only be used on flow meters with meter tubes out of transparent material. By means of the optical scanning, it is possible to register also very small flow quantities for example in case of non-metallic or small particles.

We can also supply a high temperature version for temperatures of up to 180 °C [356 °F].

The **M&C** flow alarm units **FA...** are designed for stationary continuous operation and provide a long service life and a minimum of maintenance work presuming a correct installation.

### 6.1 PATENTED FLOW ALARM SENSOR

The patented optical flow alarm sensors (forked light barriers) **FA1/2/3bi** are produced by **M & C TechGroup** GmbH, D- 40885 Ratingen. **[PATENT-No.: 3528270]**

## 7 APPLICATION

In the analyse technique, the optical flow alarm sensors **FA-1/2/3bi** are used for the flow monitoring in flow meters with meter tubes made of transparent material, for example Duran glass. By means of the optical scanning, it is possible to detect also very low flow quantities in flow meters with non-metallic or very small particles (1 mm).

The **M&C** electronic controllers series **FA®** are to be used for operating the flow alarm sensors **FA-1/2/3bi** and **FA2-H** as well as the liquid sensor **KS2/KS3** (not KS2.EX/KS3 EX).

## 8 TECHNICAL DATA

Flow alarm sensor Type	FA-1, bi	FA-2, bi	FA-3, bi
Part-No.	<b>02E1000</b>	<b>02E2000</b>	<b>02E3000</b>
Meter tube	5 to 14 mm [approx. 0.2" to 0.55"]	13 to 27 mm [approx. 0.51" to 1.06"]	26 to 55 mm [approx. 1.02" to 2.17"]
Dimensions (W x D x H)	35 x 23 x 15 mm [approx. 1.38" x 0.91" x 0.59"]	63 x 40 x 22 mm [approx. 2.48" x 1.57" x 0.87"]	103 x 75 x 25 mm [approx. 4.06" x 2.95" x 0.98"]
Weight	50 g [approx. 0.11 lb]	100 g [approx. 0.22 lb]	200 g [approx. 0.44 lb]
Operating temperature	-25 to +70 °C [-13 to 158 °F]		
Storage temperature	-25 to +70 °C [-13 to 158 °F]		
Electrical connection	3 m [approx. 9.84 ft] connection cable standard; ø 4.5 mm, 4 cores (for each additional meter of sensor connection cable = Part-No.: <b>02E9000</b> , max. 10 m [approx. 32.81 ft] ) (>10 m [approx. 32.81 ft] = with pre-amplifier K-FA.. max. 200 m [approx. 656.17 ft])		
Mounting	With clamping screw		
Function	Bi-stable and mono-stable		
Power supply voltage	From electronic controller FA...		
Protection type	IP65 EN 60529		
Material	Aluminium anodised, epoxy, PVC cable, semi-conductors		

Electronic Controller Type	FA-1.1	FA-1.4	K-FA**
230 V 50/60 Hz 115 V 50/60 Hz 24 V DC 24 V AC	<b>02E7300*</b> <b>02E7300*</b> <b>02E7300 d</b> <b>02E7300 b</b>	<b>02E7110</b> <b>02E7110 a</b> <b>02E7110 d</b> <b>02E7110 d</b>	<b>02 E 4020</b>
Mounting	Wall mounting housing	Rail mounting housing EN 50022	Wall mounting housing
Sensor inlets	1		
Function mono-stable / bi-stable / KS2/KS3	all, selectable via electrical assignment mono- or bi-stable		
Power consumption	2 VA	1 VA	
Alarm Relay (MC/NC/NO) Contact rating max.	250 V AC/DC AC=500 VA, DC=50 W, 3 A	250 V AC/DC, AC=500 VA, DC=45 W, 2 A	
Pull-in/drop-off time lag of alarm relay	2 s		
Cable inlet	1x clamping range 3 mm – 6.5 mm 2x clamping range 5 mm – 10 mm		1x clamping range 3 mm – 6.5 mm 1x clamping range 5 mm – 10 mm
Electrical connection	Terminals max. 2.5 mm <sup>2</sup>		
Adjustment of sensitivity for sensor FA..	After removing the lid on the potentiometer	On the front side of the housing on the potentiometer	



Electronic Controller Type	FA-1.1	FA-1.4	K-FA**
Distance between sensor and electronic FA-..	max. 10 m [approx. 32.81 ft]		>10 m [approx. 32.81 ft], max. 200 m [approx. 656.17 ft]
Line break monitoring	Yes		
Protection type	IP65 EN 60529	IP20 EN 60529	IP65 EN 60529
Housing material	Polycarbonate	Polyamide	Polycarbonate
Ambient temperature	-25 °C to +60 °C [-13 to 140 °F]		
Electrical standard	EN61010		
Dimensions	(W x L x H) 80 x 160 x 55 mm [approx. 3.15" x 6.3" x 2.17"]	(W x L x D) 22.8 x 100 x 111 mm [approx. 0.9" x 3.94" x 4.37"]	(W x L x H) 80 x 160 x 55 mm [approx. 3.15" x 6.3" x 2.17"]
Weight	0.31 kg [approx. 0.68 lb]	0.18 kg [approx. 0.4 lb]	0.3 kg [approx. 0.66 lb]

\* reversible mains voltage 230 V 50 Hz / 115 V 60 Hz, adjusted at works: 230 V 50 Hz.

\*\*To be used in connection with electronic controller FA-1.1 or FA-1.4 for cable lengths of above 10 m between forked light barrier and electronic controller

## 9 DESCRIPTION

The **M&C** flow alarm sensor **FA-1/2/3bi** consists of a compact aluminium body with a fixed, open prism and a pressure screw. This makes the positioning of the flow alarm sensors **FA-1/2/3bi** onto the measuring glass of the flow meter very easy; it is **not** necessary to disassemble the measuring glass. Three basic versions **FA-1bi**, **FA-2bi** and **FA-3bi** cover a measuring glass diameter range of 5-55 mm. Inside the sensor's body, a mechanically protected, high-intensity LED is mounted on the left side as light source and two phototransistors are mounted on the opposite side as receivers. The standard connection cable of 3 m [approx. 9.84 ft] comes out on the left side laterally to the pressure screw. The light beam of the LED meets the photo transistors through the flow measuring glass. As soon as the floating particles interrupt the light beam, one or both phototransistors are blacked out.

The **M&C** electronic controllers series **FA**<sup>®</sup> are available in 2 housing types for wall mounting or rail mounting. Both types contain three service functions to be determined via the electrical connection:

- Electronic controller for flow monitoring in **bi-stable** execution in combination with the flow alarm sensors (forked light barriers) **FA-1/2/3bi**.
- Electronic controller for flow monitoring in **mono-stable** execution in combination with the flow alarm sensors **FA-1/2/3bi** or **FA2-H**.
- Electronic controller for liquid sensor **KS2/KS3** or operation in combination with the external pre-amplifier **K-FA**, in case the cable length between flow alarm sensor **FA-1/2/3bi** and electronic **FA-1..** is more than 10 m [approx. 32.81 ft] or in case of strong straying signals influencing the evaluation via the sensor cable.

For sure operation, a line break monitoring is integrated. For sure alarm signalling a potential-free change-over contact with „Safety-first“ switching is existing. In order to avoid unwanted alarm signals in case of pulsating gas flow, the alarm switch has got a pull-in and drop-off time-lag. Two LED's are signalling operational or fault status.

The electronic controllers **FA-1..** are balanced in the factory relating to the flow alarm sensors **FA-1/2/3bi** and the measuring glasses of the flow meter **FM-40** 7-70NL/h. Additionally, the luminosity of the flow monitoring sensor **FA-1/2/3bi** is automatically controlled in dependence on the ambient and operating conditions (lighting conditions, temperature, ageing of the LED's, contamination of the flow meter glass, etc.).

In case of operating a bi-stable flow monitoring, the identification of the set flow value adjusted by the flow alarm sensors **FA-1/2/3bi** is guaranteed in case of exceeding or falling below the present value (**MIN** or **MAX**). In case of mono-stable operation, there is only an indication given whether the floating particle is located in the light beam of the flow alarm sensor **FA-1/2/3bi** or above or below it (see figure 1).

## 10 RECEIPT OF GOODS AND STORAGE

- Please take the flow alarm units **FA...** and eventual special accessories carefully out of the packaging material immediately after arrival, and compare the goods with the items listed on the packing list.
- Check the goods for any damage caused during delivery and, if necessary, notify your transport insurance company without delay of any damage discovered.

The flow alarm units **FA...** are containing 1 to 4 parts depending on the desired range of delivery:

1. Flow alarm sensor **FA-.bi**
2. Electronic controller **FA-1..**
3. Pre-amplifier **K-FA**
4. Flow meter **FM...**

## 11 INSTALLATION INSTRUCTIONS

In case a complete monitoring unit containing forked light barrier, electronic controller and flow meter is ordered, we will execute a balance in our works with the flow meter FM-40 7-70 NI/h. This balancing may also be appropriate for other flow meters depending on the ambient conditions (lighting conditions). Should this not be the case, see chapter 14.2 and 14.3.

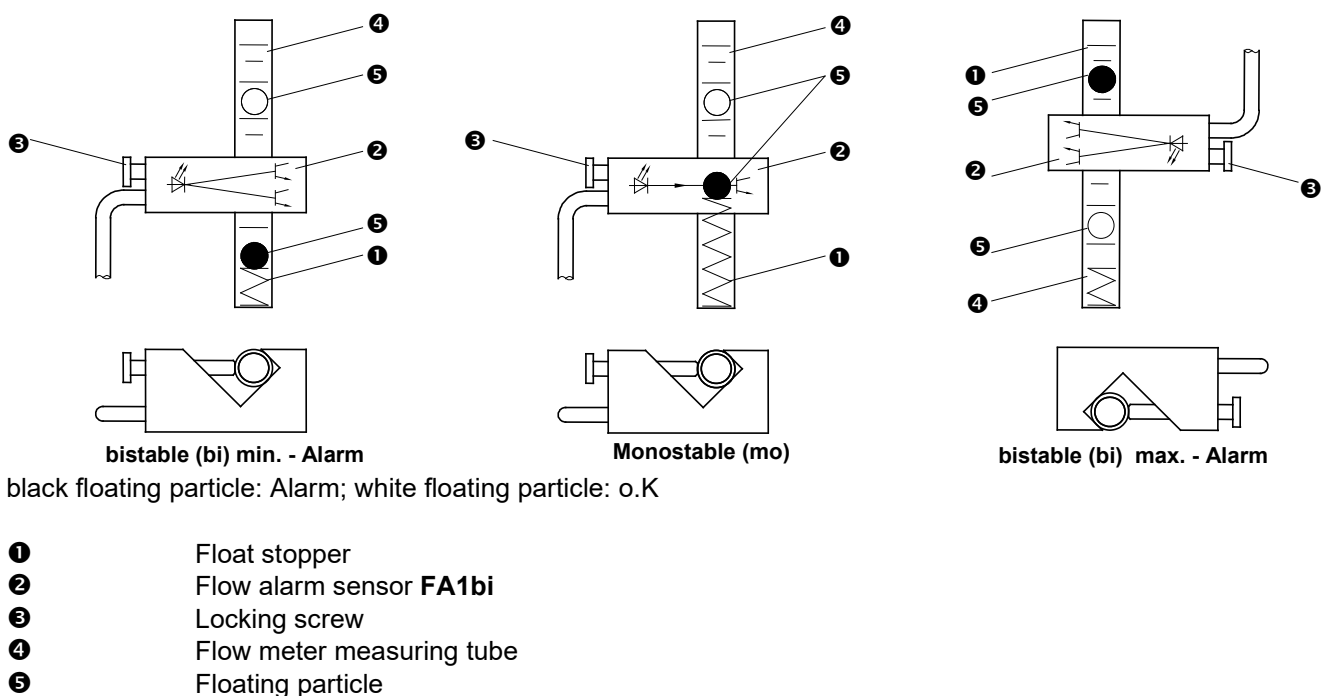

**Figure 1** FA-1/2/3bi on measuring glass with bi-stable or mono-stable function

## 12 MOUNTING

Fix the flow alarm sensor ②, while the connection cable points to the left side (**M&C**-imprinting is readable) and using the locking screw ③ onto the flow meter's measuring tube ④ on the desired control point for a min.-alarm (floating particle is situated in normal operation above the flow alarm sensor) in such a way that the light beam of the flow alarm sensor will not be deflected by eventual inscriptions or coloured background of the measuring tube.

The design of the optical flow alarm sensor (forked light barrier) provides perfect function in case of normal day light or normal illumination. A strong incidence of light from outside to the sensor should however be avoided.

In case the flow alarm sensor is mounted by 180° distorted, (connection cable points to the right side), the function is reversed (max.-alarm, floating particle is in normal operation below the forked light barrier).

The electronic controller **FA1.1** is destined for wall mounting. Mounting dimensions see figure 2, page 13 .

The electronic controller **FA1.4** is destined for rail mounting according to EN 50022. Mounting dimensions see figure 3, page 14.

## 13 ELECTRICAL CONNECTION



**WARNING!**

**Incorrect power supply may destroy the device. When connecting the equipment, please ensure that the supply voltage is identical with the information provided on the type plate!**



**WARNING!**

**When setting high-power electrical units with nominal voltages of up to 1000 V, attention must be paid to the requirements of VDE 0100 together with the associated standards and stipulations! A main switch must be provided externally.**



**The main circuit of the device must be equipped with a fuse corresponding to the nominal voltage (over current protection); for electrical details see technical data.**

The sensor cable should not be too short when being fixed in order to assure a simple dismounting of the forked light barrier in case of control or cleaning.

The electronic controllers **FA-1.1** are equipped with a selector switch S3 for the power supply of 230 or 115 V. At the factory, this switch is adjusted to 230 V. Before starting, check the desired supply voltage and adjust the selector switch if necessary by means of a screw driver.

The electronic controllers **FA-1.4** in 24 V execution are suitable for both direct voltage as well as alternating voltage.

### 13.1 ELECTRONIC CONTROLLER FA-1.1

For the electrical connection, the following steps have to be executed (see figure 2):

- Loosen the 4 lid screws and remove the lid.
- Direct the connection cable through the respective clamping screws.
- The electrical connection of the sensors **FA-1/2/3bi** is to be made according to the colours of the terminals 5 = yellow, 6 = green, 7 = white and 8 = brown.
- The electrical connection of the sensor **KS2/KS3** and the pre-amplifier **K-FA..** is to be made according to the colours of the terminals 15 = yellow, 16 = green, 17 = white and 18 = brown.
- The voltage supply occurs on the terminals 1 = L, 2 = N and 3 = PE.
- The alarm is to be connected to terminal 11 = centre contact (MC), 12 = alarm (NC) and 14 = o.k. (NO).
- For a mono-stable evaluation, the attached jumper must be mounted between terminals 16 and 17 (this is not necessary for operation with pre-amplifier **K-FA..** because a bi-stable or mono-stable operation is set on the pre-amplifier (see chapter 13.3))

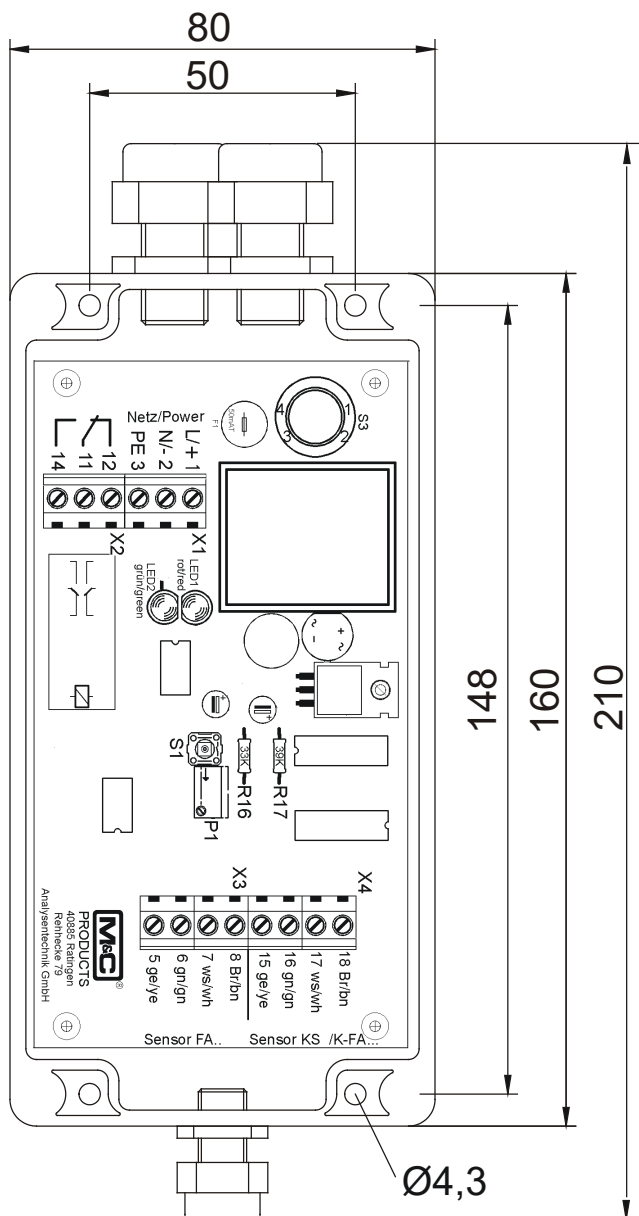

Figure 2 Electrical connection and dimensions FA-1.1

### 13.2 ELECTRONIC CONTROLLER FA-1.4

For the electrical connection, the following steps have to be carried out (see also figure 3):

- The electrical connection of the sensors **FA-1/2/3bi** is to be made on the terminals 5 = yellow, 6 = green, 7m = white and 8 = brown.
- The electrical connection of sensor **KS2/KS3** and the pre-amplifier **K-FA..** is to be made on the terminals 15 = yellow, 16 = green, 17 = white and 18 = brown.
- The voltage supply happens on the terminals 1 = L, 2 = N and 4 = PE.
- The alarm is to be connected to terminals 11 (MC), 12 (NC) and 14 (NO). In case of alarm contact 11 and 12 are closed and voltage free.
- For a mono-stable evaluation, the attached jumper must be mounted between the terminals 16 and 17 (this is not necessary for operation with pre-amplifier **K-FA..** because a bi-stable or mono-stable operation is set on the pre-amplifier (see chapter 13.3))

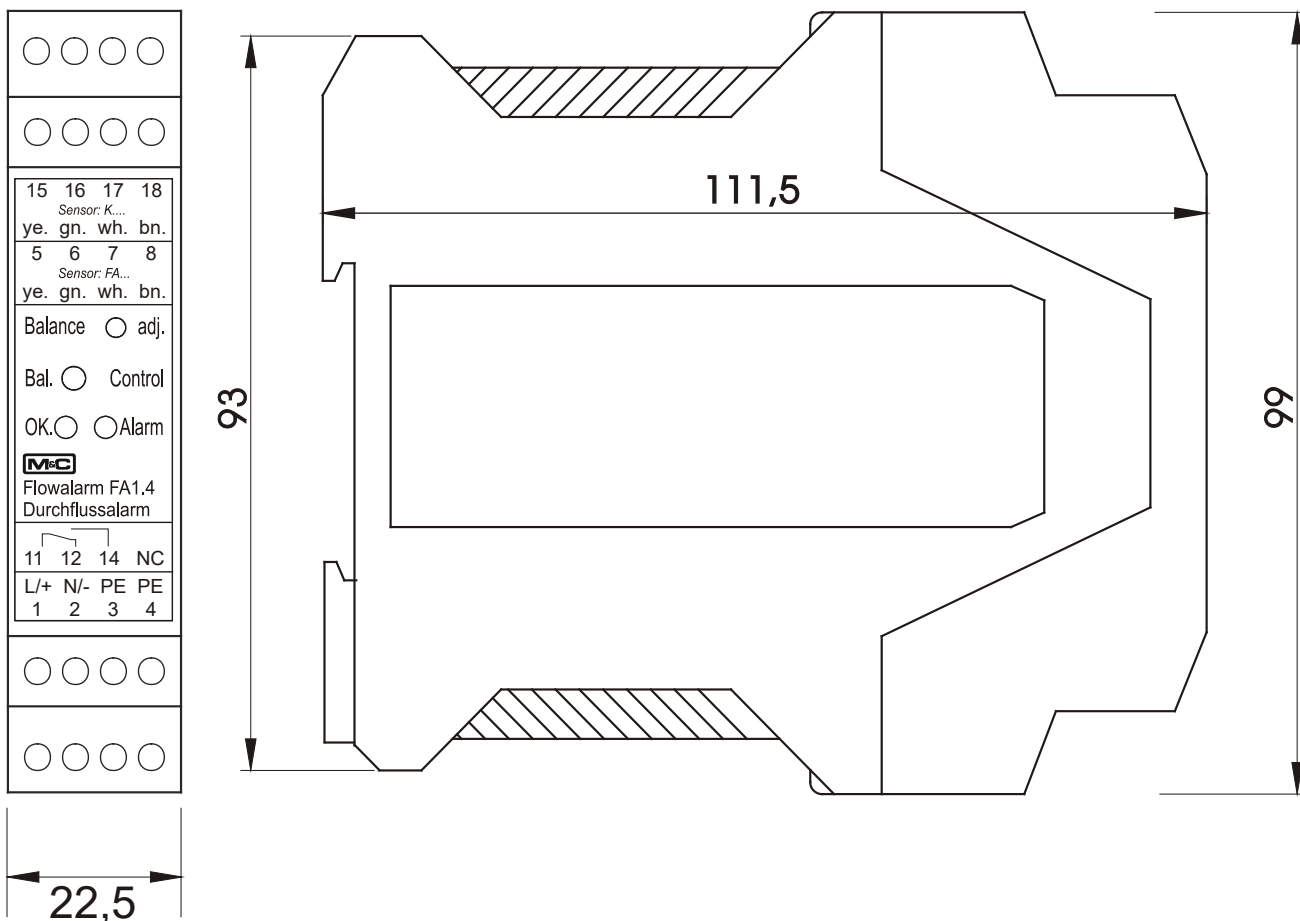

Figure 3 Electrical connection and dimensions FA-1.4

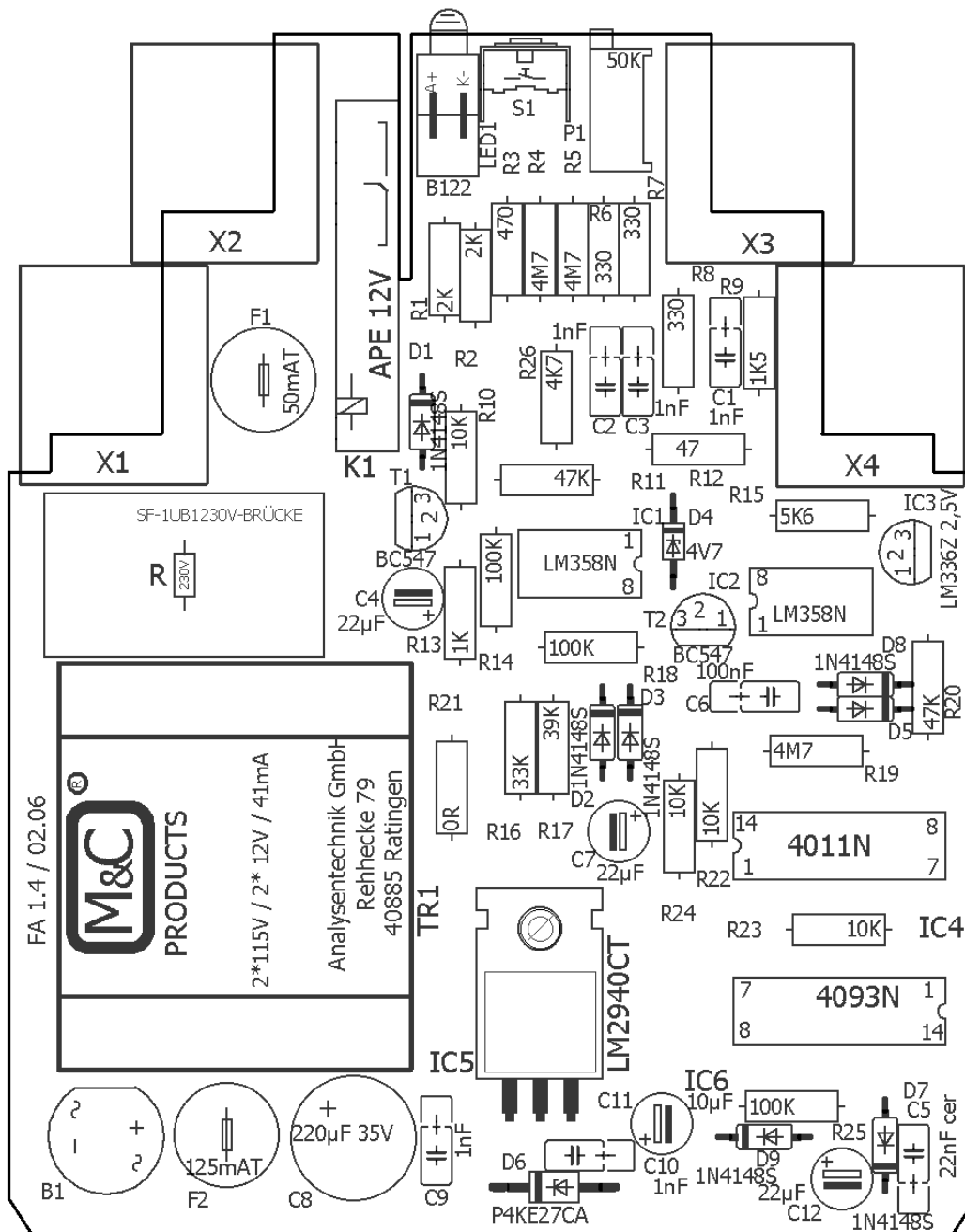

Figure 4 Assembly plan of the FA-1.4

### 13.3 PRE-AMPLIFIER K-FA

For the electrical connection, the following steps have to be carried out (see also figure 4):

- Loosen the 4 lid screws and remove the lid.
- Lead the connection cable through the respective clamping screws.
- The electrical connection of the sensors **FA-1/2/3bi** is to be made on the terminals 5 = yellow, 6 = green, 7 = white and 8 = brown, clamping block X2.
- The electronic controller **FA-1..** is to be mounted on clamping block X1, terminals 5 = yellow, 7 = white and 8 = brown.
- The function mono-stable or bi-stable is determined via the 3 jumpers S1, S2 and S4.

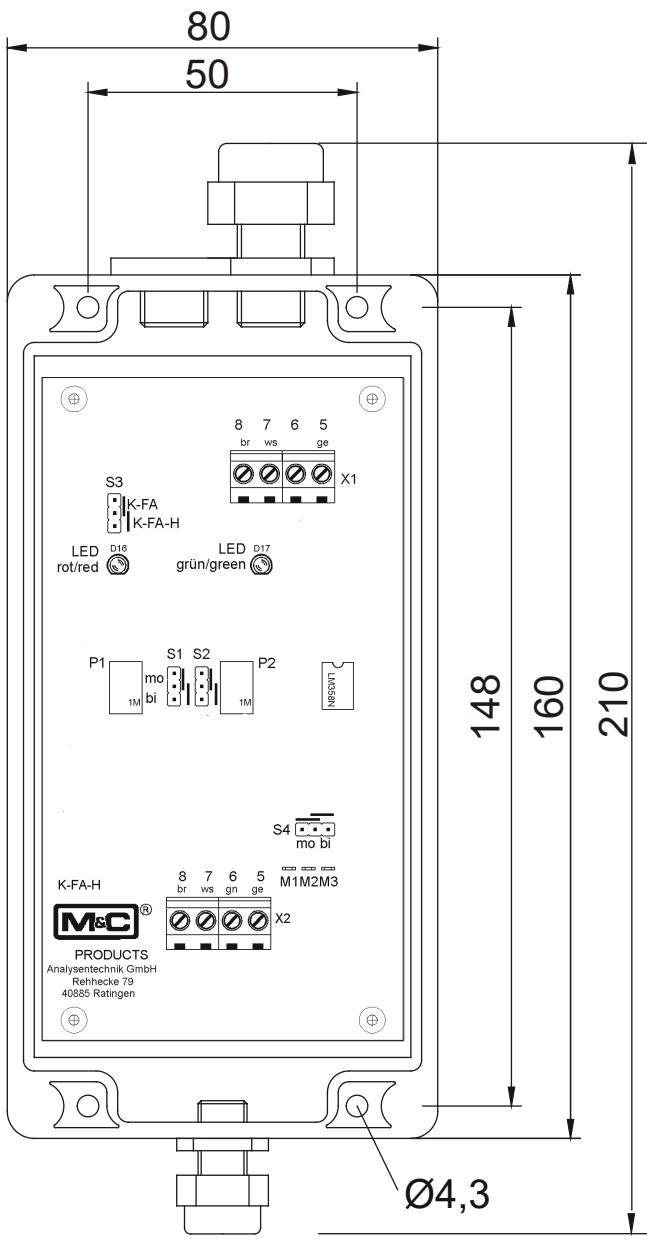

Figure 5 Electrical connection K-FA



## 14 STARTING



**WARNING!**

**Wrong power supply may destroy the equipment. When connecting, make sure that the supply voltage is identical with the information provided on the model type plate!**



- Without feeding of gas, the floating particle ⑤ is placed on the float stopper ① on the bottom of the flow meter measuring glass.
- In case of mono-stable function, the sensor is fixed to the meter tube in such a way that the floating particle is placed on the lowest position (alarm point) and the light beam of the sensor is blacked out. For adjusting the alarm level, the float stopper must be regulated.
- In case of bi-stable function, the sensor is fixed to the meter tube in such a way that it marks the necessary minimum flow rate (min. alarm) or the maximum admissible flow rate (max. alarm).
- Switch on the power supply for the electronic controller.
- The red LED of the electronic controller or the pre-amplifier is beaming – **alarm situation**.
- Move the floating particle ⑤ by feeding of gas into a position above the flow alarm sensor ②.
- The green LED of the electronic controller or the pre-amplifier is beaming - **O.K. situation**.

The flow control unit is ready for work!



**NOTE!**

**For bi-stable electronic controller:**

**If the floating particle ⑤ is situated above the flow alarm sensor ② when starting and before the power supply of the electronic controller FA-1.. is switched, the red LED is beaming and signals alarm (Safety-First-switching). The same applies in case of a short-time voltage failure during operation.**

**This alarm is cleared by cutting first and re-feeding of gas.**

### 14.1 SENSITIVITY ADJUSTMENT FOR ELECTRONIC CONTROLLERS FA1.1 AND FA1.4

The standard adjustment of the electronic controllers **FA-1..** is made at works for the flow alarm sensor (forked light barrier) **FA-1bi** and the measuring glasses of the flow meters **FM-40** for 7-70NI/h.

If the client composes a system with single components and if the alarm function is not given in case of using other measuring glasses than ours, the adjustment of the forked light barriers **FA-1/2/3bi** can be made as follows:

- The forked light barrier must be mounted onto the flow meter glass.
- The floating particle of the flow meter must not be inside the light beam of the forked light barrier **FA-1/2/3bi**.
- Concerning the wall mounting version **FA-1.1** : Loosen the 4 screws and remove the lid. Press the button S1 and search simultaneously the respective spot on the potentiometer P1 where the LED indication changes from red to green or from green to red (turn clockwise in order to change from red to green).

- Concerning the rail mounting version **FA-1.4** : Press the button Bal.-Control and search simultaneously the respective spot on the potentiometer (Balance-adj.) where the LED indication changes from red to green or from green to red.

## 14.2 SENSITIVITY ADJUSTMENT FOR USE OF PRE-AMPLIFIER K-FA..

When using a pre-amplifier **K-FA..**, the sensitivity adjustment is only to be made on the pre-amplifier and not on the connected electronic controller **FA-1..** .

- For executing the sensitivity adjustment, loosen the 4 screws and remove the lid.
- Adjust the voltage signal on the electronic board of the pre-amplifier **K-FA..** for both photo transistors to a value between +0.08 (lowest sensitivity) to + 0.18 V DC (highest sensitivity). The tension is to be measured on the connection points of the sensor's connection cables or the soldering points M1 – M3. The adjustment is to be made on the potentiometers P1 and P2.



**NOTE!**

**When adjusting the sensitivity, the following principle should be considered:  
As sensitive as necessary, as insensitive as possible.**

**ws** (white) resp. **M2** = lower phototransistor, adjustable at **P1**  
**gn** (green) resp. **M1** = upper phototransistor, adjustable at **P2**  
**ge** (yellow) resp. **M3** = earth

- Measurement to be made in **bi-stable** version between:  
**ge** (yellow) resp. **M3 = 0V** and **ws** (white) resp. **M2 = +V** (lower phototransistor)  
**ge** (gelb) resp. **M3 = 0V** and **gn** (green) resp. **M1 = +V** (upper phototransistor)
- Measurement to be made in **mono-stable** version between:  
**ge** (yellow) resp. **M3 = 0 V** and **ws** (white) resp. **M2 = +V** (only lower phototransistor)

## 14.3 ADJUSTMENT OF THE DELAY TIME

By applying the following, unwanted alarm indication in case of pulsating gas flow can be avoided.

Slow operation: Alarm release is given with a time-lag.

Slow release: Alarm is given with a time-lag.

**The electronic board is accessible as follows:**

- In wall mounting version **FA-1.1** by removing the 4 lid screws.
- In the **FA-1.4** rail mounting version, the locking mechanism is released behind the terminals at the top and bottom using a screwdriver. The printed circuit board can then be pulled out of the rear part of the housing together with the front of the housing

The pick-up and drop-out time delay of the alarm relay is adjustable with the fixed resistors **R16/R17** at the adjusting points on the electronic board of the electronic controller **FA-1..** .  
The position of the resistors is to be seen in figures 2 and 4.

Resistor		Slow operation	Resistor		Slow release
R17	1 K $\Omega$	approx. 0 seconds	R16	1 K $\Omega$	approx. 0 seconds
R17	100 K $\Omega$ *	approx. 3 seconds	R16	100 K $\Omega$ *	approx. 2 seconds
R17	270 K $\Omega$	approx. 7 seconds	R16	270 K $\Omega$	approx. 6 seconds
R17	560 K $\Omega$	approx. 11 seconds	R16	560 K $\Omega$	approx. 10 seconds
R17	1 M $\Omega$	approx. 14 seconds	R16	1 M $\Omega$	approx. 13 seconds

\* Standard adjustment at works = 33 K $\Omega$  and 39 K $\Omega$  = 1 second pick-up and drop-out time delay  
The times represent approximate values and are dependent on the tolerances of the components.

## 15 CLOSING DOWN

For closing down the equipment, no special measures are to be taken.

## 16 MAINTENANCE AND REPAIR



**NOTE!**

**Before carrying out any maintenance or repair work, the specific safety procedures pertaining to the system and the operational process have to be observed!**

The flow control units series **FA**<sup>®</sup> are functioning without necessity of maintenance over a long time. It may be that the LED and the phototransistors of the flow alarm sensor **FA-1/2/3bi** must be cleaned due to dust deposits.

Please execute this cleaning with a dry cotton bud (Q-tip). If you want to humid this cotton bud, do only use water !

If there is any defect on the electronics, please return the device for repair to **M&C**.

## 17 LIST OF SPARE PARTS

The consumable and spare parts requirements depend on the specific operating conditions. The recommended quantities are based on experience and are not binding.

### Flow alarm unit FA...

(C) Consumable parts, (R) Recommended spare parts and (S) Spare parts		Recommended quantity for operation time of:			
		C/R/S	1	2	3
02E1000	<b>Sensor FA-1bi:</b> Optical flow sensor <b>FA-1,bi</b> with 3 m connection cable	S	-	-	1
02E1010	<b>Sensor FA-1bi:</b> Optical flow sensor <b>FA-1,bi</b> with 6 m connection cable	S	-	-	1
02E9000	<b>Sensor FA-1bi:</b> Connection cable FA..., per meter	S	-	-	1

## 18 ANNEXE

Circuit diagram **FA1.1**, 115/230 V

Circuit diagram **FA1.1**, 24 VAC

Circuit diagram **FA1.4**, 115/230 V

Circuit diagram **FA1.4**, 24 V AC/DC

Circuit diagram **K-FA (-H)**



For further product documentation, please see our internet catalogue:

[www.mc-techgroup.com](http://www.mc-techgroup.com)

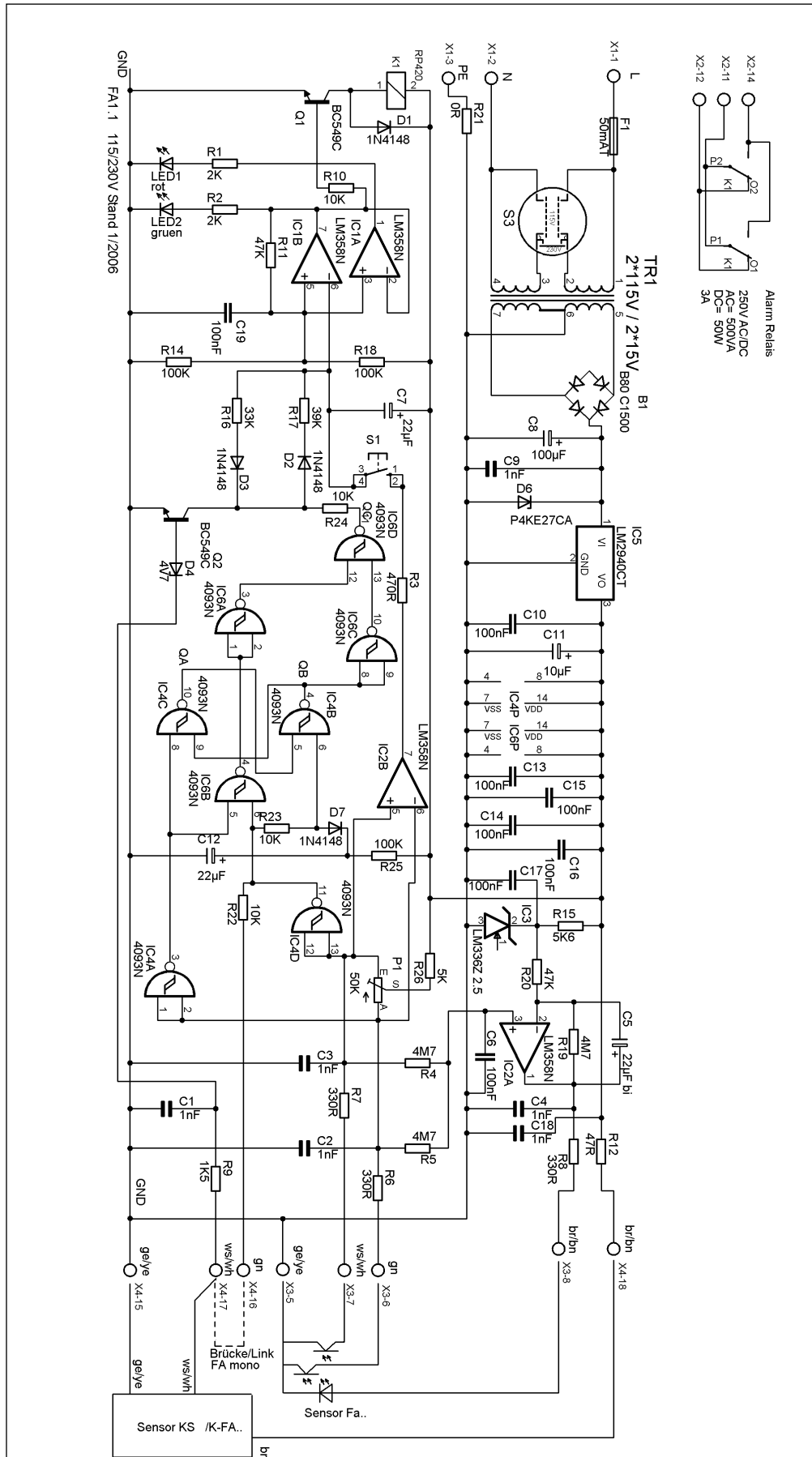

Figure 6 Circuit diagram of the electronic controller FA1.1, 115/230 V

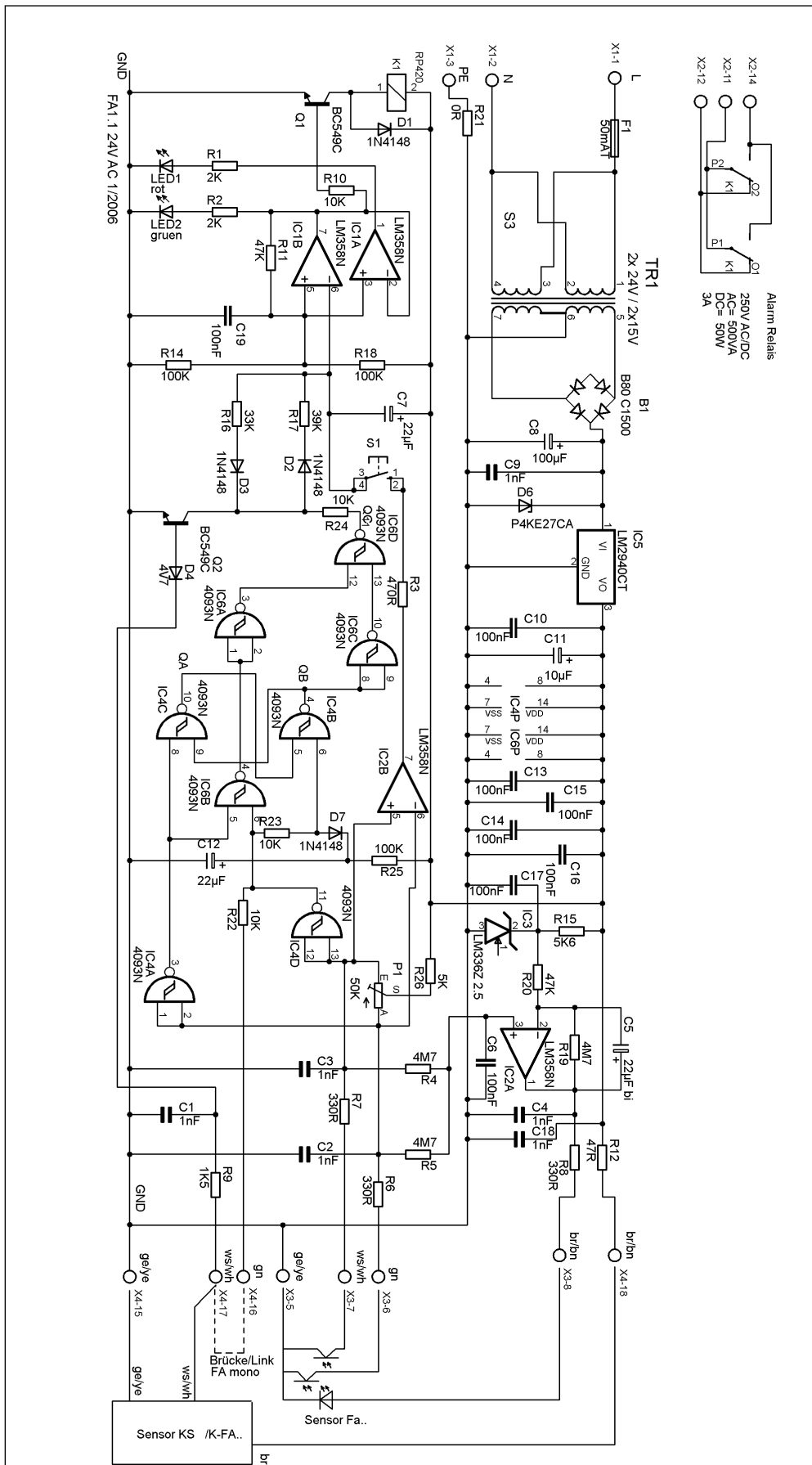

Figure 7 Circuit diagram of the electronic controller FA1.1, 24 V AC

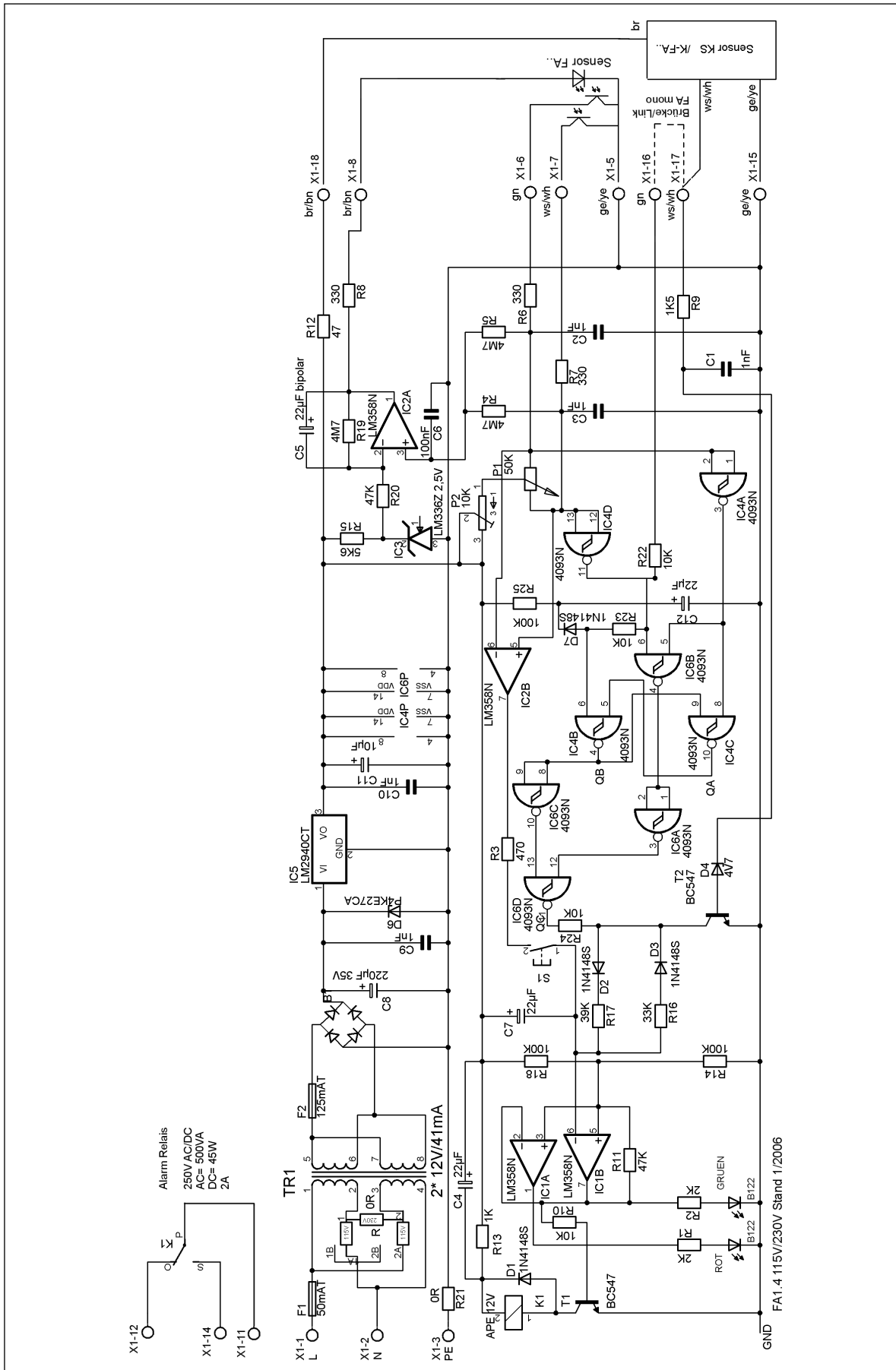

Figure 8 Circuit diagram of the electronic controller FA1.4, 115/230 V

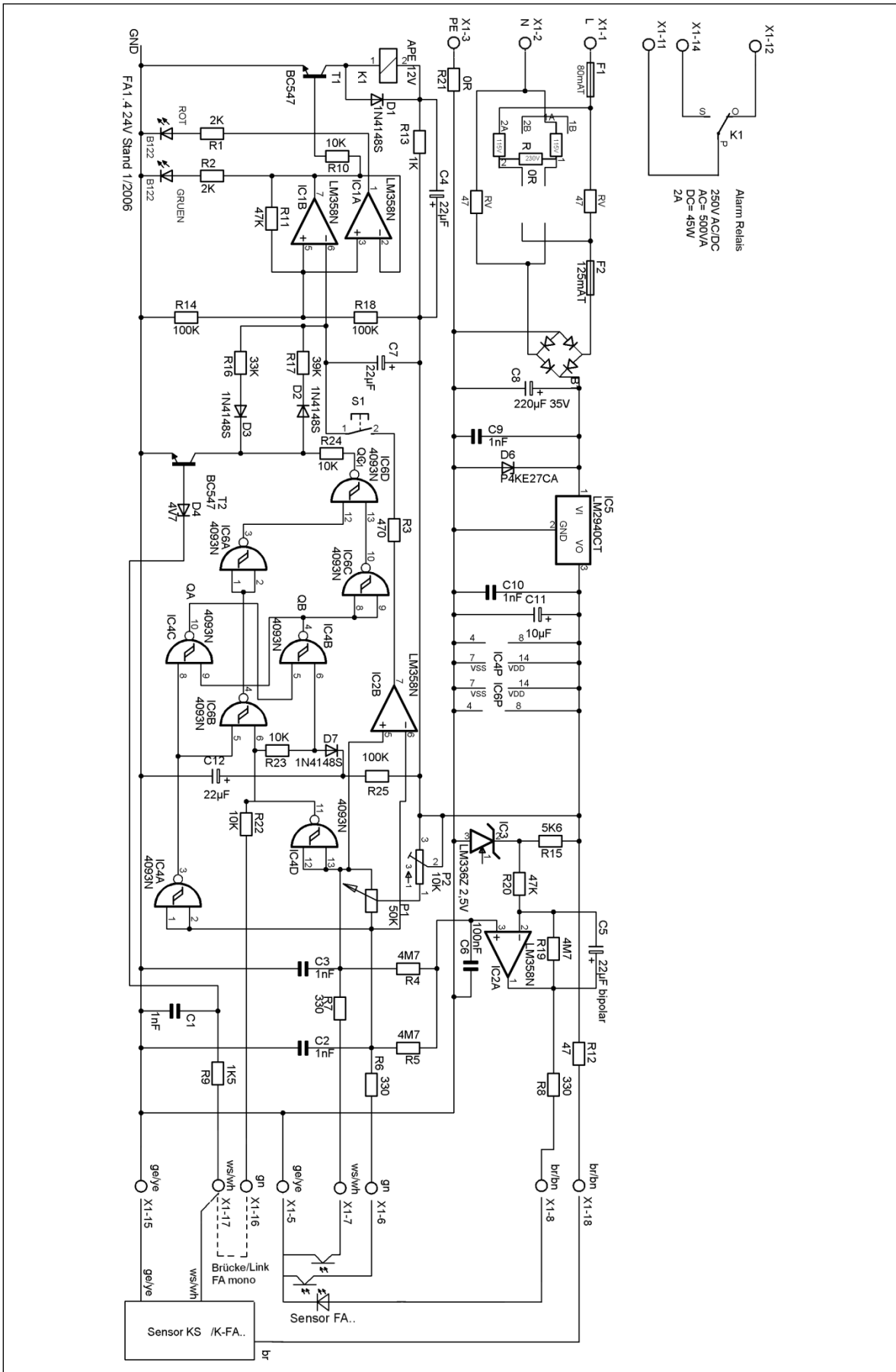

Figure 9 Circuit diagram of the electronic controller FA1.4, 24 V AC/DC



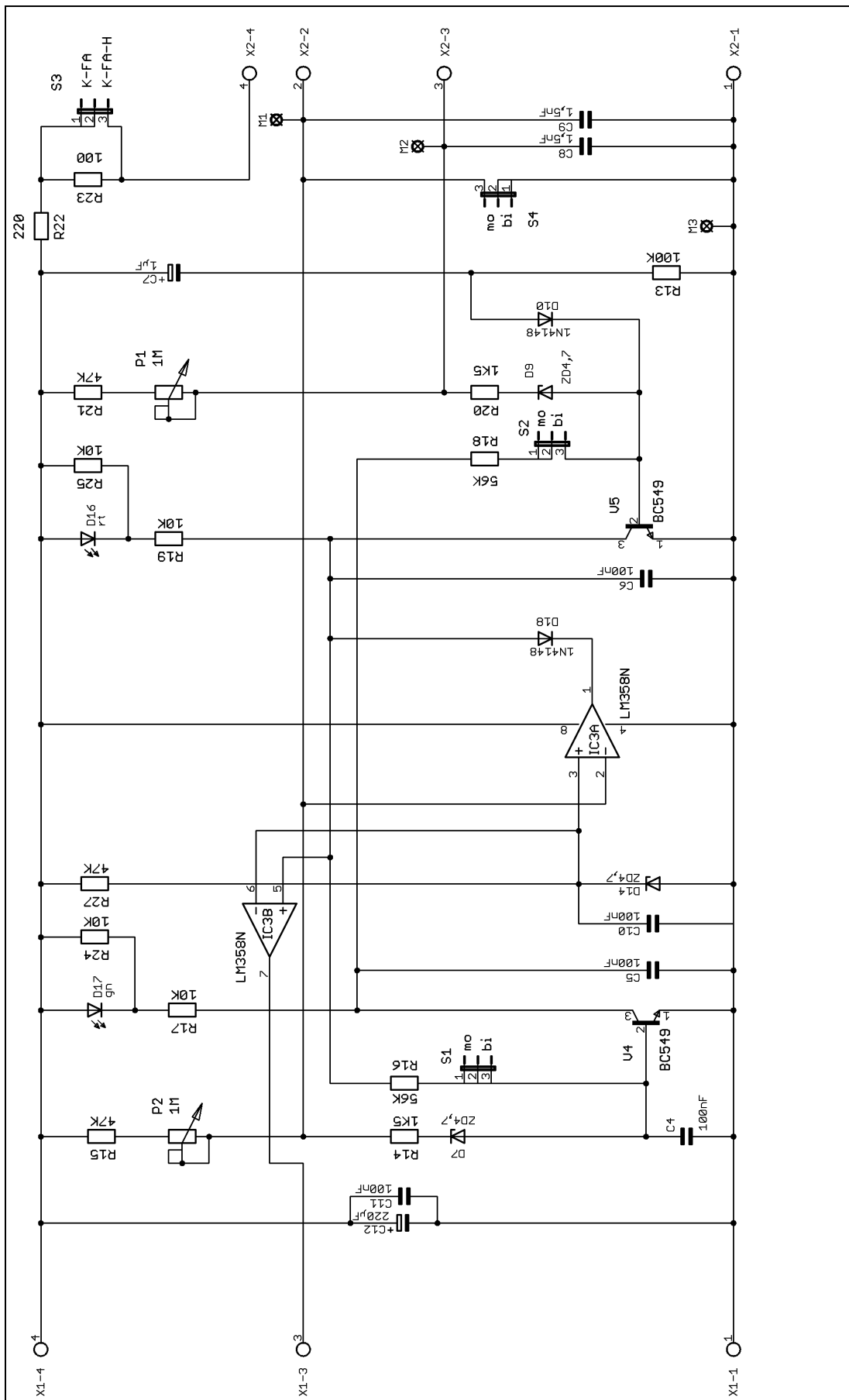

Figure 10 Circuit diagram of the electronic controller K-FA (-H), 115/230 V