

# Gas Sample Probe Series SP<sup>®</sup>

## SP10, SP10-H

Instruction Manual  
Version 1.00.01





**Dear customer,**

we have made up this operating manual in such a way that all necessary information about the product can be found and understood quickly and easily.

Should you still have any question, please do not hesitate to contact **M&C** directly or go through your appointed dealer. Respective contact addresses are to be found in the annexe to this operating manual. Please also contact our homepage [www.mc-techgroup.com](http://www.mc-techgroup.com) for further information about our products. There, you can read or download the data sheets and operating manuals of all **M&C** products as well as further information in German, English and French.

This Operating Manual does not claim completeness and may be subject to technical modifications.

© 04/2016 **M&C TechGroup Germany GmbH**. Reproduction of this document or its content is not allowed without permission from **M&C**.

**SP®** is a registered trade mark.

Version: 1.00.01

## Content

1	General information .....	4
2	Declaration of conformity .....	4
3	Safety instructions .....	5
4	Warranty .....	5
5	Used terms and signal indications .....	6
6	Introduction .....	7
7	Technical Data .....	7
8	Application .....	8
9	Description .....	8
10	Probe design .....	8
11	Receipt of goods .....	9
12	Preparation for Installation .....	10
13	Mounting .....	10
14	Electrical connections .....	11
15	Start up .....	12
16	Maintenance .....	13
17	Closing down .....	13
18	Spare parts list .....	14
19	Appendix .....	14

## List of illustrations

Figure 1	Dimensions SP10-H .....	9
Figure 2	Electrical connection SP10-H .....	12

## Head Office

**M&C TechGroup Germany GmbH** ♦ Rehhecke 79 ♦ 40885 Ratingen ♦ Germany

Telephone: 02102 / 935 - 0

Fax: 02102 / 935 - 111

E - mail: [info@mc-techgroup.com](mailto:info@mc-techgroup.com)

[www.mc-techgroup.com](http://www.mc-techgroup.com)

## 1 GENERAL INFORMATION

The product described in this operating manual has been examined before delivery and left our works in perfect condition related to safety regulations. In order to keep this condition and to guarantee a safe operation, it is important to heed the notes and prescriptions made in this operating manual. Furthermore, attention must be paid to appropriate transportation, correct storage, as well as professional installation and maintenance work.

All necessary information a skilled staff will need for appropriate use of this product are given in this operating manual.

## 2 DECLARATION OF CONFORMITY



The product described in this operating manual complies with the following EU directives:

### EMV-Instruction

The requirements of the EU directive 2014/30/EU "Electromagnetic compatibility" are met.

### Low Voltage Directive

The requirement of the EU directive 2014/35/EU "Low Voltage Directive" are met.  
The compliance with this EU directive has been examined according to DIN EN 61010.

### Declaration of conformity

The EU Declaration of conformity can be downloaded from the **M&C** homepage or directly requested from **M&C**.

### 3 SAFETY INSTRUCTIONS

Please take care of the following basic safety procedures when mounting, starting up or operating this equipment:

Read this operating manual before starting up and use of the equipment. The information and warnings given in this operating manual must be heeded.

Any work on electrical equipment is only to be carried out by trained specialists as per the regulations currently in force.

Attention must be paid to the requirements of VDE 0100 (IEC 364) when setting high-power electrical units with nominal voltages of up to 1000 V, together with the associated standards and stipulations.

Check the details on the type plate to ensure that the equipment is connected to the correct mains voltage.

Protection against touching dangerously high electrical voltages:

Before opening the equipment, it must be switched off and hold no voltages. This also applies to any external control circuits that are connected.

The device is only to be used within the permitted range of temperatures and pressures.

Check that the location is weather-protected. It should not be subject to either direct rain or moisture.

The equipment must not be used in hazardous areas.

Installation, maintenance, monitoring and any repairs may only be done by authorized personnel with respect to the relevant stipulations.

### 4 WARRANTY

If the equipment fails, please contact **M&C** directly or else go through your **M&C** authorised dealer. We offer a one year warranty as of the day of delivery as per our normal terms and conditions of sale, and assuming technically correct operation of the unit. Consumables are hereby excluded. The terms of the warranty cover repair at the factory at no cost or the replacement at no cost of the equipment free ex user location. Reshipments must be send in a sufficient and proper protective packaging.

## 5 USED TERMS AND SIGNAL INDICATIONS



**DANGER!**

This means that death, severe physical injuries and/or important material damages **will occur** in case the respective safety measures are not fulfilled.



**WARNING!**

This means that death, severe physical injuries and/or important material damages **may occur** in case the respective safety measures are not fulfilled.



**CARE!**

This means that minor physical injuries **may occur** in case the respective safety measures are not fulfilled.

**CARE!**

Without the warning triangle means that a material damage may occur in case the respective safety measures are not met.

**ATTENTION!**

This means that an unintentional situation or an unintentional status may occur in case the respective note is not respected.



**NOTE!**

These are important information about the product or parts of the operating manual which require user's attention.

**SKILLED STAFF**

These are persons with necessary qualification who are familiar with installation, use and maintenance of the product.

## 6 INTRODUCTION

**M&C** gas sample probes provide direct insitu ultra-fine filtration during continuous gas sampling for analytic measurements. In this way, part of the necessary maintenance work for a system is concentrated on a single point. This filter technology has the major advantage that dust mixtures consisting of ultra-fine and coarse dusts can be optimally retained with the least possible maintenance work.

Optimal adaptation of the **M&C** gas sample probe to processing conditions and to measurement work is a necessary condition for a measurement system to work smoothly. Basically, the gas sample should be kept to a necessary minimum. This is made possible thanks to optimised downstream gas processing using **M&C** components. Only in this way it is possible to reduce maintenance to a minimum while ensuring maximum availability.

## 7 TECHNICAL DATA

Series <b>SP</b> <sup>®</sup>	Version <b>SP10</b>	Version <b>SP10-H</b>
Part No.	<b>01 S 1000</b>	<b>01 S 2000</b>
System of protection	IP54 EN60529	
Sample temperature	V10 max.600°C * optional HC max. 900 °C	
Sample pressure	0,4 bis 6 bar abs.*	
Ambient temperature	-20°C bis +60°C	
Dust load	max. 10 g/m <sup>3</sup> *, optional higher 10 g/m <sup>3</sup>	
Insitu probe length	270 mm*	
Heater temperature adjustable	+100 bis +200°C, optional with PT100 without controller	
Ready for operation	after 1 h	
Sample gas outlet connection	1/8"-NPT internal for tube connectors max. Ø 10mm	
Power supply	230V/50Hz / 240V/60Hz 315W, optional 115V/60Hz 300W	
Electrical connection	terminals max 4mm <sup>2</sup> , 1x PG13,5 cable gland	
Electrical equipment standard	EN60529/61010, EN 60519-1	
Mounting flange	DN65 PN6, Form B , rostfr. Stahl 1.4571	
Material of sample connecting parts	SS316, SS316Ti, Novapress*	
Weight	4 kg	

\* Standard

\*\* In case of higher ambient temperatures use option PT100 (Part No. 20S9025) or thermocouple Fe-CuNi respectively Ni-CrNi (Part No. 20S9027 resp. 20S9028) instead of the thermostat controller. Then, an additional electronic temperature controller (see data sheet 2-5.1) is necessary.

## 8 APPLICATION

The **M&C** gas sample probes **SP10** respectively **SP10-H** are used for continuous gas sampling in processes with dust loadings up to 10g/m<sup>3</sup>, operating pressures up to max. 6 bar abs., temperatures up to max. 600°C and high gas humidities. The modular design allows the combination of different pre-filter materials (max. 900°C) and length (>10g/m<sup>3</sup>) and therefore an optimum adaption to the process conditions. The compact design requires only little space.



**NOTE!**

**Install the probe at a weather-protected sample point. For outdoor applications please use a version with option weather protection shield.**

## 9 DESCRIPTION

The **M&C** gas sample probes are designed for easy installation, reliable operation and trouble-free maintenance. Advantages are:

- Gas sampling with dust loaded processes;
- Low volume, fast response time;
- Different pre-filters as an option.

The gas sample probe is heated up to max. +200°C.

## 10 PROBE DESIGN

The probe head with its all-round heating element forms a unit with the standard mounting flange DN65 PN6 and the laterally mounted junction box.

A mounting clamp and a 1/8" internal thread are located on the underside of the probe for the connection of heated **M&C** gas sampling lines with external diameters of 40mm to a max. 55mm and a tube diameter of max. 10mm.

After assembly of the sample line and the tube connector the sample gas outlet connection is enclosed with the heat conducting shells. The maximum operating temperature for stainless steel pre-filters type **V10..** is 600° C and for the pre-filters **V10..HC** 900°C.

The modular system of our gas sample probes allows the usage of all **M&C** pre-filters type **V10** and extension tubes type **Vo** and **Vm** with 1" thread. This guarantees an optimal adaptation to the process conditions.

The following cross-sectional drawing shows the gas sample probe **SP10-H**.



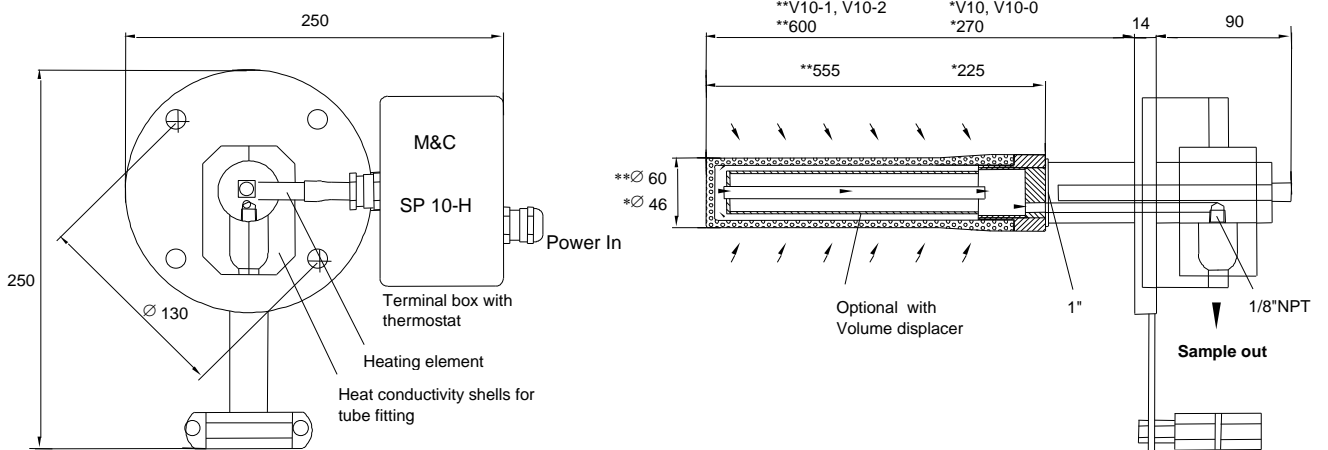

**Figure 1**      **Dimensions SP10-H**

## 11      **RECEIPT OF GOODS**

The **M&C** gas sample probe is normally delivered in one unit. It comprehends the gas sample probe with pre-filter, screws, nuts and flange gasket.



**NOTE!**

**The gas sample probe should be removed carefully from the packaging and checked immediately for completeness against the delivery note. Check the goods for any damage incurred during transport and if necessary inform your transport insurer of any damage.**

## 12 PREPARATION FOR INSTALLATION

Please pay attention to the following points:

- Select the optimal sampling point in accordance with the generally applicable guidelines or consult the competent persons.
- Locate the sampling point in such a way that there is adequate space for inserting and removing the gas sample probe and pay attention to the insertion length of the probe tube.
- Make certain that the gas sample probe is easily accessible so that you can carry out any subsequent maintenance work without trouble.
- Design and isolate the bleeder connection in such a way that the temperature of the whole connection is always above the acid dew point in order to avoid corrosion and blockage problems.
- If the ambient temperature in the area of the bleeder connection is  $>80^{\circ}\text{C}$  as a result of radiated heat, then a radiated heat deflector must be mounted to protect the probe.
- The mounting flange at the bleeder connection should comply with DN65 PN6. If other connection sizes are required, a special adapter flange can be supplied as an option (Part No. 20S9004) .

Before mounting, the gas sample probe must be adjusted to the existing operating conditions. We recommend to check the existing parameters accordingly to the following table:

<i>Weatherproof mounting position</i>	<i>_____ present</i>	<i>_____ install</i>	
<i>Low/overpressure situation</i>	<i>mbar</i>	<i>bar</i>	
<i>Process temperature</i>	<i>°C, Min.</i>	<i>°C, Max.</i>	
<i>Dust loading</i>	<i>g/m<sup>3</sup></i>		
<i>Dust composition - grain size</i>	<i>µm</i>		
<i>Gas composition</i>	<i>corrosive</i>	<i>toxic</i>	<i>explosive</i>
<i>Parameters to be measured, e.g. O<sub>2</sub>, CO, SO<sub>2</sub>, NO<sub>X</sub>, ...</i>	<i>Vol.%</i>	<i>mg/Nm<sup>3</sup></i>	<i>ppm</i>
<i>Required gas flow</i>	<i>l/rh, Min.</i>	<i>l/hr, Max.</i>	
<i>Required reaction time T<sub>90</sub></i>	<i>sec.</i>		

## 13 MOUNTING

**M&C SP10** resp. **SP10-H** gas sample probes are designed for stationary use and if properly selected and mounted a long service life and maintenance are guaranteed.

It is advisable to mount the gas sample probe in a position which has a  $10^{\circ}$  inclination to the process (not necessary for the function of the probe ).

Screw the prefilter directly on to the 1" outer thread with the 1" flat gasket and tighten.

If an extension tube is used, it should be mounted between the gas sample probe and the pre-filter.

If the gas sample probe connection does not correspond to the standard flange connection DN65 PN6, then the optionally supplied adapter flange should be mounted to the probe.

Before fixing the gas sample probe at the bleeder connection first attach the flange gasket to the mounting flange.

The temperature-resistant, stainless steel connectors supplied by **M&C** have a double-blade ring system to ensure reliable sealing. After tightening the nuts of these connectors by hand, they should then be tightened exactly  $1 \frac{1}{4}$  of a turn using a flat spanner and are then properly mounted.

**NOTE!**

**If a PTFE tube is used as sample line, an insert must be installed in the end of the tube in order to prevent the tube being pressed together !**

Now place the heat conductivity shells on the connection of the gas sample line and prove it's fit to prevent cold spots.

## 14 ELECTRICAL CONNECTIONS

For the electrical installation take the relevant safety instructions into consideration. Before connecting the probe ensure that the mains is voltage-free.

**WARNING!**

**When connecting the equipment, please ensure that the supply voltage is identical with the information provided on the model type plate!**

**NOTE!**

**Attention must be paid to the requirements of IEC 364 (DIN VDE 0100) when setting high-power electrical units with nominal voltages of up to 1000 V, together with the associated standards and stipulations!**

The junction box is mounted on the side of the gas sample probe. The wiring plan is located in the lid of the junction box. A cable bushing is available for the mains cable.

Carry out the following steps:

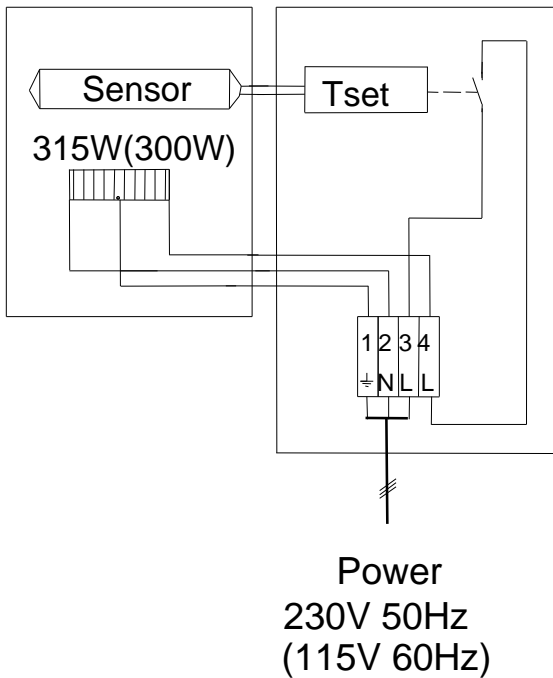

**Figure 2** Electrical connection SP10-H

- Remove the lid of the junction box;
- Insert the mains cable (min. 3 x 1.5 mm<sup>2</sup>) through the cable gland and connect it to the appropriate terminals as in the wiring above;
- Screw lid back on;

## 15 START UP

Before starting up check whether the mains power supply voltage corresponds with the information stated on the probe's nameplate.

Switch on mains power supply.

The total heating-up time is approximately 1 hour. The sample gas can now be extracted via the gas sample probe after this heating-up time.

## 16 MAINTENANCE

The safety instructions specific to the plant and process are to be consulted prior to any maintenance work!



**WARNING!**

**Before starting maintenance work on electrical parts ensure that the mains and the eventually connected alarm and control circuits are switched off completely!**



Maintenance cycles have to be carried out depending on your process or ambient conditions. An indication for a possible gas sample probe-maintenance could be a constant decline in the amount of sample gas to the analysis system.

Probe maintenance is restricted essentially on replacing or cleaning the pre-filter. The pre-filter can be cleaned for example in an ultrasonics bath.



**WARNING!**

**High surface temperatures. Wear protective gloves!**



To change or clean the pre-filter the gas sample probe has to be dismantled. For this loosen the 4 screws at the flange and remove the gas sample probe from the process. Unscrew pre-filter from the probe body and screw on the new or cleaned pre-filter.

## 17 CLOSING DOWN

Before switching off, that means switching off the heating, the **M&C** gas sample probe should be flushed with inert gas or air in order to avoid condensation of aggressive components from the process gas. After that, close gas outlet tight.

There are no other precautions to take.

## 18 SPARE PARTS LIST

Wear, tear and replacement part requirements depend on specific operating conditions. The recommended quantities are based on experience and they are not binding.

<b>M&amp;C Gas sample probe SP<sup>®</sup>10, SP<sup>®</sup>10-H</b>					
(C) Consumable part (R) Recommended spare parts (S) Spare parts					
			Recommended quantity for operation [years]		
Part No.	Description	C/R/S	1	2	3
90 S 1005	Insitu stainless steel filter type V10, without volume displacer Filter porosity: 2µm, Length: 225mm, 46mm OD, Material: SS316	V	b.d.*	b.d.*	b.d.*
90 S 1010	Insitu hastelloy filter type V10/HC, without volume displacer Filter porosity: 2µm, Length: 225mm, 46mm OD, Material: hastelloy C4	V	b.d.*	b.d.*	b.d.*
90 S 1012	Insitu hastelloy filter type V10-0/HC, with volume displacer Filter porosity: 2µm, Length: 225mm, 46mm OD, Material: hastelloy C4	V	b.d.*	b.d.*	b.d.*
90 S 1015	Insitu stainless steel filter type V10-1, with volume displacer Filter porosity: 2µm, Length: 550mm, 60mm OD, Material: SS316	V	b.d.*	b.d.*	b.d.*
90 S 1016	Insitu hastelloy filter type V10-1/HC, with volume displacer Filter porosity: 2µm, Length: 550mm, 60mm OD, Material: hastelloy C4	V	b.d.*	b.d.*	b.d.*
90 S 1017	Insitu stainless steel filter type V10-2, without volume displacer Filter porosity: 2µm, Length: 550mm, 60mm OD, Material: SS316	V	b.d.*	b.d.*	b.d.*
90 S 1018	Insitu hastelloy filter type V10-2/HC, without volume displacer Filter porosity: 2µm, Length: 550mm, 60mm OD, Material: hastelloy C4	V	b.d.*	b.d.*	b.d.*
90 S 1020	Gasket 1" for SP10/11/21/31 V10	E	b.d.*	b.d.*	b.d.*
90 S 2077	Flange gasket DN65 PN6B (67). Material: Novapress	E	b.d.*	b.d.*	b.d.*
90 S 0005	Cartridge heater element for SP10/23H, SP23, Filter H/H0, L=130mm, 230VAC/315W.	E	b.d.*	b.d.*	b.d.*
90 S 0006	Cartridge heater element for SP10/23H, SP23, Filter H/H0, L=130mm, 115VAC/300W.	E	b.d.*	b.d.*	b.d.*
90 S 0011	Thermostat 100-300°C for SP21-H/300 probe diameter 8mm.	E	b.d.*	b.d.*	b.d.*
93 S 0018	Temperature resistant heat sink compound, 100g.	E	b.d.*	b.d.*	b.d.*

\* by demand

## 19 APPENDIX



More product documentation is available on our Internet catalogue:  
[www.mc-techgroup.com](http://www.mc-techgroup.com)