

Peristaltic Pump Series SR[®]

SR25.1, SR25.2-G, SR25.1/Ex

Instruction Manual
Version 1.01.01



**Dear Customer,**

Thank you for buying our product. In this manual you will find all necessary information about this M&C product. The information in the manual is fast and easy to find, so you can start using your M&C product right after you have read the manual.

If you have any question regarding the product or the application, please don't hesitate to contact M&C or your M&C authorized distributor. You will find all the addresses in the appendix of this instruction manual.

For additional information about our products, please go to M&C's website www.mc-techgroup.com. There you can find the data sheets and manuals of our products in German and English.

This instruction manual does not claim completeness and may be subject to technical modifications.

© 02/2024 **M&C TechGroup** Germany GmbH. Reproduction of this document or its content is not allowed without permission from **M&C**.

SR® is a registered trademark.

With the release of this version all older manual versions will no longer be valid. The German instruction manual is the original instruction manual. In case of arbitration only the German wording shall be valid and binding.

Version: 1.01.01



Content

1 General information.....4
2 Declaration of conformity4
3 Safety instructions.....5
3.1 Intended use.....5
4 Warranty.....6
5 Used terms and signal indications.....6
6 Introduction.....8
7 Technical Data.....8
7.1 Options for SR25.1/Ex.....8
7.2 Dimensions.....9
8 Description10
9 Reception and storage.....11
10 Installation instructions.....12
10.1.1 Mounting instructions for peristaltic pump.....12
11 Supply connections.....13
11.1 Hose connections.....13
11.2 Electrical connections14
12 Preparations for commissioning.....15
13 Start-up15
14 Closing down.....16
15 Maintenance.....16
15.1 Changing the pump tubing.....17
15.2 Changing contact pulleys and springs.....19
15.3 Reassembly of the driver20
15.4 Cleaning the pump head.....21
16 Repair information21
17 Proper disposal of the device21
18 Spare parts list.....22
19 Risk assessment22
20 Appendix.....24

List of illustrations

Figure 1 Dimensions SR25.19
Figure 2 Dimensions SR25.1/EX.....9
Figure 3 Dimensions SR25.1/Ex in stainless steel enclosure (01P1250)10
Figure 4 Dimensions SR25.2-G.....10
Figure 5 Universal unit EC-FD with three built-in peristaltic pumps SR25.111
Figure 6 SR25.2: Mounting distance between front panel and pump motor13
Figure 7 Connection of the distribution voltage14
Figure 8 Changing the pump tubing18
Figure 9 Different pump tube sizes.....19
Figure 10 Disassembly of pump head and driver19
Figure 11 Check of axles and rolls.....20
Figure 12 Overview risk assessment.....23
Figure 13 Spare part drawing SR25.125
Figure 14 Spare part drawing SR25.226
Figure 15 EC-type examination certificate SR25.1/EX, SR25.2/EX and SR25.3/EX27



Head Office

M&C TechGroup Germany GmbH ♦ Rehhecke 79 ♦ 40885 Ratingen ♦ Germany

Telephone: 02102 / 935 - 0

Fax: 02102 / 935 - 111

E - mail: info@mc-techgroup.com

www.mc-techgroup.com

1 GENERAL INFORMATION

The product described in this instruction manual has been built and tested in our production facility.

All M&C products are packed to be shipped safely. To ensure the safe operation and to maintain the safe condition, all instructions and regulations stated in this instruction manual need to be followed. This instruction manual includes all information regarding proper transportation, storage, installation, operation and maintenance of this product by qualified personnel.

Follow all instructions and warnings closely.

Read this manual carefully before commissioning and operating the device. If you have any questions regarding the product or the application, please don't hesitate to contact M&C or your M&C authorized distributor.

2 DECLARATION OF CONFORMITY



The product described in this operating manual complies with the following EU directives:

ATEX-Directive

The product SR25.1/Ex which is described in this manual is produced in accordance with the EU directive for devices and protection systems for appropriate use in hazardous areas 2014/34/EU appendix II.

EMC-Instruction

The requirements of the EU directive 2014/30/EU "Electromagnetic compatibility" are met.

Low Voltage Directive

The requirement of the EU directive 2014/35/EU "Low Voltage Directive" are met.

The compliance with this EU directive has been examined according to DIN EN 61010.

Declaration of conformity

The EU Declaration of conformity can be downloaded from the **M&C** homepage or directly requested from **M&C**.

3 SAFETY INSTRUCTIONS

Please take care of the following basic safety procedures when mounting, starting up or operating this equipment:

Read this operating manual before starting up and use of the equipment. The information and warnings given in this operating manual must be heeded.

Any work on electrical equipment is only to be carried out by trained specialists as per the regulations currently in force.

Attention must be paid to the requirements of VDE 0100 (IEC 364) when setting high-power electrical units with nominal voltages of up to 1000 V, together with the associated standards and stipulations.

Check the details on the type plate to ensure that the equipment is connected to the correct mains voltage.

Protection against touching dangerously high electrical voltages:

Before opening the equipment, it must be switched off and hold no voltages. This also applies to any external control circuits that are connected.

The device is only to be used within the permitted range of temperatures and pressures. For details please refer to the technical data sheet or instruction manual.

Check that the location is weather-protected. It should not be subject to either direct rain or moisture.

The peristaltic pumps SR25.1 and SR25.2-G must not be used in hazardous areas.

Installation, maintenance, inspections and any repairs of the devices must be carried out only by qualified skilled personnel in compliance with the current regulations.

3.1 INTENDED USE

The peristaltic pumps SR25.1 and SR25.2-G are intended for use in general purpose areas (non-hazardous environments) only.

The peristaltic pumps SR25.1, SR25.2-G und  SR25.1/Ex can only be operated in compliance with the information starting in chapter 7. You must meet the requirements of the ambient temperature and pressure characteristics in particular.

Do not use this product for any other purpose. Improper use and handling can create hazards and cause damage. For more information, please refer to the safety information in this instruction manual.

4 WARRANTY

In case of a device failure, please contact immediately M&C or your M&C authorized distributor.

We have a warranty period of 12 months from the delivery date. The warranty covers only appropriately used products and does not cover the consumable parts. Please find the complete warranty conditions in our terms and conditions.

The warranty includes a free-of-charge repair in our production facility or the free replacement of the device. If you return a device to M&C, please be sure that it is properly packaged and shipped with protective packaging. The repaired or replaced device will be shipped free of delivery charges to the point of use.

5 USED TERMS AND SIGNAL INDICATIONS



Danger

means that death, serious personal injury and/or substantial property damage will result if proper precautions are not taken.



Warning

indicates that death, serious personal injury and/or substantial property damage might occur if proper precautions are not taken.



Caution

means that minor personal injury may result if proper precautions are not taken.

Caution

without a warning triangle symbol, indicates that property damage may result if proper measures are not taken.



Note

This is important information about the product or the appropriate part of the manual to which particular attention should be paid.

Qualified personnel

These are persons who are familiar with the installation, commissioning, maintenance and operation of the product and have the necessary qualifications through training or instruction. Qualified personnel must have at least the following knowledge:

- Instructed person in EX-protection (for devices used in hazardous areas only)
- Trained person in the electrotechnical field
- Detailed knowledge of the operating instructions and the applicable safety regulations



'EX' indicates important information about the product or about the corresponding parts in the instruction manual, relating to usage in potentially explosive atmospheres.



High voltages!
Protect yourself and others against damage which might be caused by high voltages.



Toxic!
Acute toxicity (oral, dermal, inhalation)! Toxic when in contact with skin, swallowed or inhaled.



Corrosive!
These substances destroy living tissue and equipment upon contact. Do not breathe vapors; avoid contact with skin and eyes.



Hot surface!
Contact may cause burn! Do not touch!



Caution, risk of being crushed due to rotating parts.
Do not open the device. Use personal protective equipment (PPE).



Wear protective gloves!
Working with chemicals, sharp objects or extremely high temperatures requires wearing protective gloves.



Wear safety glasses!
Protect your eyes while working with chemicals or sharp objects. Wear safety glasses to avoid getting something in your eyes.



Wear protective clothes!
Working with chemicals, sharp objects or extremely high temperatures requires wearing protective clothes.



Use foot protection



Use safety helmet and full protective goggles

6 INTRODUCTION

The peristaltic pump **SR25...** has been specially developed for the condensate removal in analysis applications. It ensures a continuous condensate discharge at gas sample coolers, condensate collecting vessels, etc.

Synchronous motor and gearing unit with return stop make a condensate backflow impossible. The capacity of 0.3 l/h guarantees a safe condensate removal, for example when cooling 850 l/h sample gas with an inlet dew point of +70 °C [158 °F] to a temperature of 5 °C [41 °F].

7 TECHNICAL DATA

Peristaltic pump series SR25°	Version SR25.1	Version SR25.2-G	Version SR25.1/Ex
Part No.	01P1000	01P1120	01P1201
Housing	No	Yes, out of PVC	No
Method of mounting	Surface-mounted/ built-in	Wall mounting	Surface-mounted/ built-in
Protection/electrical standard	IP 10 EN60529	IP 52 EN60529	IP40,  II 2 G EEx m II T5 certificate no. KEMA 03ATEX2218 X
Electrical connection	Terminals 1.5 mm ²	Terminals 1.5 mm ² 1 x M20 x 1.5	600 mm [≈ 23.6"] cable 4 x 0.5 mm ² with cable gland M12 x 1.5
Dimensions (W x H x D)	80 x 110 x 130 mm [≈ 5.12" x 4.33" x 3.15"]	105 x 126 with cable gland x 106.5 mm [4.1" x 5.0" with cable gland x 4.2"]	80 x 110 x 130 mm [≈ 5.12" x 4.33" x 3.15"]
Weight	0.6 kg [≈ 1.32 lb]	0.8 kg [≈ 1.76 lb]	0.7 kg [≈ 1.54 lb]
Peristaltic pump speed	5 rpm standard		
Capacity	0.3 l/h standard		
Pressure min..	200 mbar abs.		
Pressure max.	2200 mbar abs.		
Sample temperature	0 to +60 °C [32 to 140 °F]		
Ambient temperature	0 to +50 °C [32 to 122 °F]		+5 to +50 °C [41 to 122 °F]
Storage temperature	-10 to +60 °C [14 to 140 °F]		
Connections	Tube connections DN 4/6 mm		
Material of sample contacting parts	PVDF, Novoprene		
Power supply / consumption	115/230 V 50/60 Hz, 3.5 VA		
Continuous duty	100 %		

7.1 OPTIONS FOR SR25.1/EX

Part No.	SR25.1/Ex with Ex connection box and enclosure
01P1250	1 x SR25.1/Ex peristaltic pump with Ex connection box and SS enclosure for one peristaltic pump, dimensions of the SS enclosure with wall brackets (W x H x D): 205.5 x 240 x 179 mm [≈ 8.1" x 9.4" x 7.0"]
01P1260	2 x SR25.1/Ex peristaltic pumps with Ex connection box and SS enclosure for up to 4 peristaltic pumps, dimensions (W x H x D): 400 x 235 x 175 mm [≈ 15.7" x 9.3" x 6.9"]
01P1270	3 x SR25.1/Ex peristaltic pumps with Ex connection box and SS enclosure for up to 4 peristaltic pumps, dimensions (W x H x D): 400 x 235 x 175 mm [≈ 15.7" x 9.3" x 6.9"]
01P1280	4 x SR25.1/Ex peristaltic pumps with Ex connection box and SS enclosure for up to 4 peristaltic pumps, dimensions (W x H x D): 400 x 235 x 175 mm [≈ 15.7" x 9.3" x 6.9"]

Option Ex-connecting box for SR25.1/Ex	Version for one peristaltic pump	Version for 4 peristaltic pumps
Part number	01P9400	01P9405
Electrical connections/cable glands	Terminals max. 4 x 2.5 mm ² /1 x M20 x 1.5, 1 x M12 x 1.5	Terminals max. 16 x 2.5 mm ² /1 x M20 x 1.5, 4 x M12 x 1.5
Protection/electrical standard	IP65, II 2 G EEx e II T5	
Dimensions (W x H x D)	75 x 80 x 55 mm [≈ 2.95" x 3.15" x 2.17"]	160 x 75 x 55 mm [≈ 6.3" x 2.95" x 2.17"]
Weight	0.35 kg [≈ 0.77 lb]	0.6 kg [≈ 1.32 lb]

7.2 DIMENSIONS

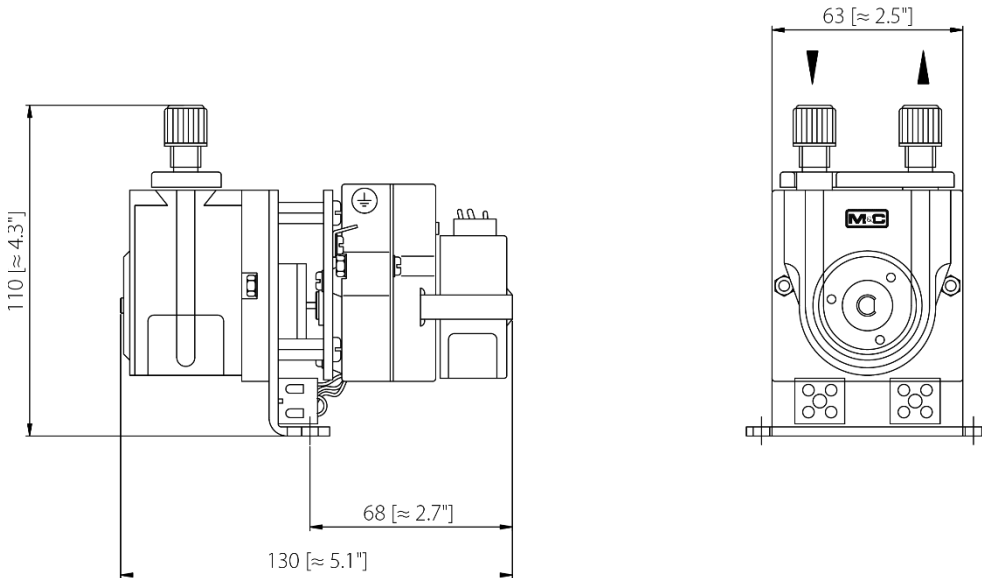

Figure 1 Dimensions SR25.1

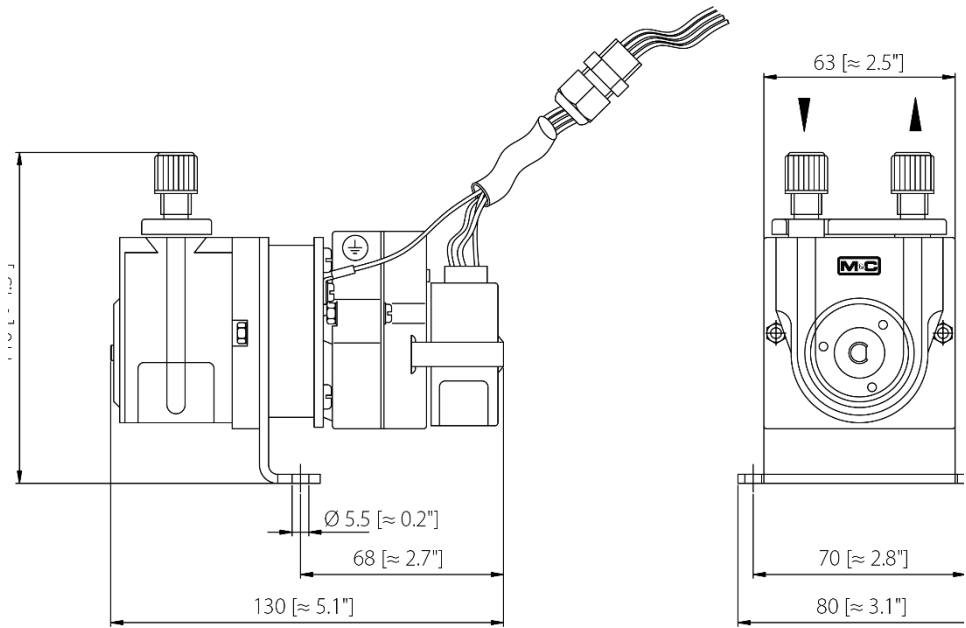

Figure 2 Dimensions SR25.1/EX

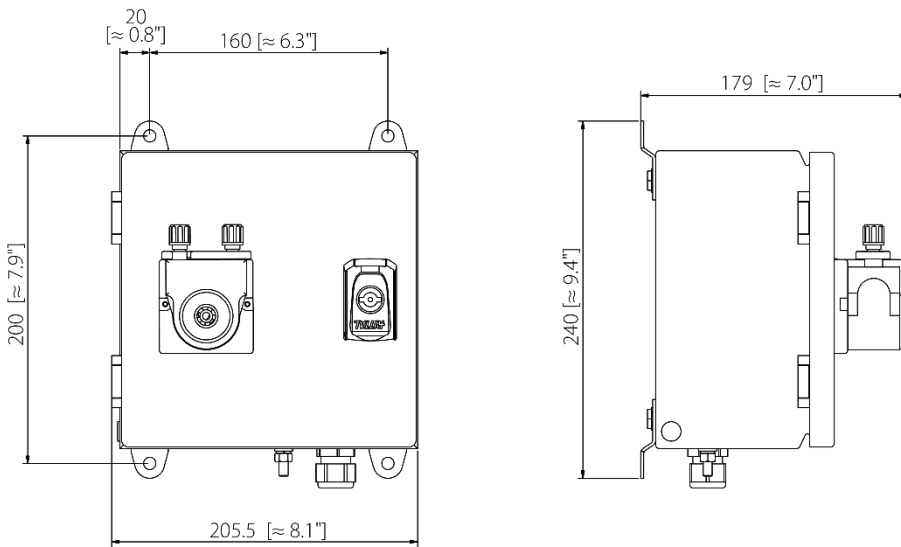

Figure 3 Dimensions SR25.1/Ex in stainless steel enclosure (01P1250)

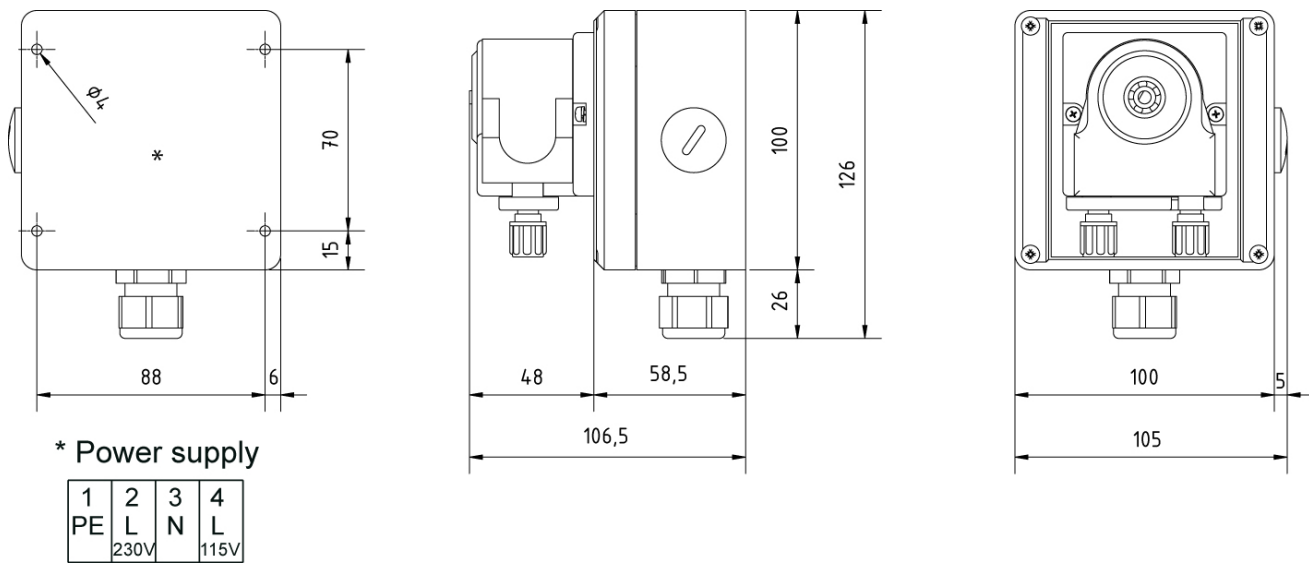

Figure 4 Dimensions SR25.2-G

8 DESCRIPTION

The peristaltic pump **SR25.1** is self-suctioning and designed for continuous operation. It consists of 3 compact parts:

- synchronous motor,
- gearing unit with return stop,
- pump.

The slow speed (5 rpm) of the two PVDF hose contact pulleys together with the novoprene hose guarantee a good mechanical and chemical resistance with a long service life.

**Note**

The compatibility of the tube material with unknown gases has to be checked before using.

The use of ready-made tubing sets means that tubing can be changed easily and without the use of tools. The screw-on DN4/6 tubing connections also allow the connection of PTFE tubing.

The peristaltic pump **SR25.1...** is supplied with electric mains for 230 V/50 Hz and 115 V/60 Hz.

- The peristaltic pump **SR25.2-G** is supplied in a wall-mount housing.
- Up to 4 peristaltic pumps **SR25.1** can be installed in the universal unit EC-FD.
- Up to 4 peristaltic pumps **SR25.1Ex** can be installed in the universal unit EC-D/EX.



Figure 5 Universal unit EC-FD with three built-in peristaltic pumps SR25.1

9 RECEPTION AND STORAGE

The peristaltic pump is a complete pre-installed unit.

- Carefully inspect the peristaltic pump and any special accessories included with it immediately on arrival by removing them from the packing and checking for missing articles against the packing list !
- Check the items for any damage in transit and, if required, inform the shipping insurance company immediately of the damage found !

**Note**

The peristaltic pump must be stored in a weather protected frost-free area!

10 INSTALLATION INSTRUCTIONS

When installing the pump make certain that accident prevention regulations and safety instructions including those for subsequent operation are observed. The safety instructions in section must be observed.

The following ambient conditions must be observed:

- Ambient temperature: max. +50 °C [122 °F]
- The pump must be protected against water and dust.
- In operation a sufficient cooling air supply must be guaranteed.



Danger

The peristaltic pumps SR25.1 and SR25.2-G must not be operated in hazardous areas.



Note

The pump must only be used in the conditions specified in the technical data. The pump should be installed away from heat sources and freely ventilated to prevent any accumulation of heat.

For outdoor installation, the pump must be installed in a housing protected from frost in the winter and sufficiently ventilated in summer. Exposure to direct sunlight must be avoided.



Danger

It is therefore essential to provide protection for persons against contact with alive parts (e.g. electrical connections, motor windings) and moving parts (e.g. fan). Protection against the entry of foreign bodies must also be provided.



10.1 MOUNTING INSTRUCTIONS FOR PERISTALTIC PUMP SR25.2

Make sure to mount the pump to the front of the cooler with a minimum distance of 3.5 mm [\approx 0.138"] and a maximum distance of 5.5 mm [\approx 0.216"] between the pump motor and the front panel. The minimum distance avoids damage to the pump motor and the maximum distance prevents the motor shaft from getting loose.

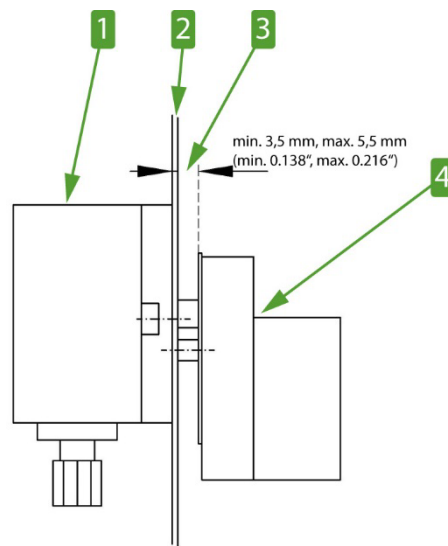

- | | |
|--|--|
| 1 Pump head (outside the device housing) | 2 Device front panel |
| 3 Recommended mounting distance | 4 Pump motor (inside the device housing) |

Figure 6 SR25.2: Mounting distance between front panel and pump motor

11 SUPPLY CONNECTIONS

11.1 HOSE CONNECTIONS

The tube connections are on the upper side of the pump. The standard threaded hose couplings are DN4/6. Tube connections with hose nipples are available as an option (see spare parts list chapter 18).



Note

Do not mix up hose-/tube connections for sample gas inlet and outlet; the connections are marked accordingly! Check for tightness of all sample lines after connection!

The hoses are to be assembled as follows:

1. Remove the union nut from the sealing ring couplings by turning it anti-clockwise. The nut should be removed from the thread with great care so as to ensure that the loose sealing ring in the nut is not lost.
2. Place the union nut over the connecting hose.
3. Place the sealing ring over the connecting hose with the thicker bead towards the nut.
4. Place the hose over the nipple on the thread.
5. The union nut is to be screwed tight by hand.

The hose will no longer be able to slip off and is now compression-proof.



The tightness of the connections can only be guaranteed if the connection hose has a straight rim (use a hose cutter).



Aggressive condensate is possible.

Chemical burns caused by aggressive media possible!



Wear protective gloves and protective glasses!

Wear proper protective clothing!

11.2 ELECTRICAL CONNECTIONS

Connect the cables for the power supply as follows:

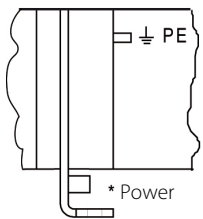

SR25.1

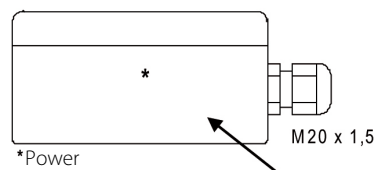
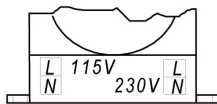

*Power

1	2	3	4
PE	L 230V	N	L 115V

SR25.2-G

For connection of the mains loosen the 4 fixing screws of the housing and open it !

Figure 7 Connection of the distribution voltage



Incorrect system voltage can damage the unit. When establishing connections, check that the system voltage corresponds with the voltage shown on the type plate! The supply voltage is only allowed to deviate max. +6% resp. -10% from the indication on the model type plate.



Attention must be paid to the requirements of IEC364 (DIN VDE 0100) when setting high-power electrical units with nominal voltages of up to 1000V, together with the associated standards and stipulations.

The electrical connection of the **SR25.1/Ex** must be done in a separate EExe box with the cable gland M12 x 1 included:

230 V - blue and red
115 V - blue and white.



The respective cable which is left (230 V white and 115 V red) must be connected at a separate terminal.

- The main circuit of the pump type **SR25.1**, **SR25.1/EX** and **SR25.2-G** must be equipped with a fuse (0.25 A recommended) corresponding to the nominal current (over current protection EN 60335-1);
- An appliance to separate the motor from the power is to be provided in the electrical installation (EN 60335-1);
- The pump must be installed so that contact with alive parts (connections, possibly windings) is impossible.

12 PREPARATIONS FOR COMMISSIONING

Before initial startup, all plant- and process-specific safety measures must be observed. It is mandatory for the operator to complete the enclosed risk assessment of the product.

The gas exposure risk must be assessed by the operator with regard to the hazards posed by process and calibration gas and the setup at the installation site (e.g. tubing, system cabinet/container/plant). If the risk assessment reveals increased exposure hazards, further measures are required.

A visible label must be attached to the installation site in accordance with the risk assessment provided by the operator.

13 START-UP

Specific safety instructions for media being handled must be observed. Before pumping a medium, the compatibility of the flexible tube material with the medium must be checked. The following steps should be carried out before initial start-up:

- The maximum permissible operating pressure (see technical data) must not be exceeded, even when the flow is restricted.
- Ambient conditions: see technical data.

14 CLOSING DOWN



Note

The area in which the pump is situated when not in use must be kept free of frost at all times!

If the pump is putting out of action be sure that the pressure in the lines is atmospheric.

On short-term decommissioning of the peristaltic pump no special measures need to be taken.

For long-term decommissioning, it is recommended to flush the peristaltic pump with ambient air or inert gas. A flushing time of 3 to 5 minutes is sufficient under normal conditions.



Warning

Aggressive condensate is possible.



Chemical burns caused by aggressive media possible!

When disassembling, repairing or cleaning, wear safety glasses and proper protective clothing!

15 MAINTENANCE

Before the maintenance work is carried out, it is necessary that the specific safety procedures pertaining to the system and operational process are observed!



Danger

Dangerous voltage!

It is necessary to take the pump off the mains before any assembly, maintenance or repair work is carried out!



Aggressive condensate is possible.

Chemical burns caused by aggressive media possible!



Wear protective gloves and protective glasses!



Wear proper protective clothing!



Explosion hazard due to wear and tear! Therefore, a regular inspection of all pump components is necessary according to the following maintenance plan.

Flexible tube, conveying belt, contact pulleys and contact springs are the only parts of the pump subject to wear. They are simple to change.



If you send back the peristaltic pump to the M&C service for repair, please let us know what kind of condensate has been pumped. Before sending the pump back clean all parts from dangerous or highly aggressive contaminants.

Inspect the following pump components	Action
Pump	Check pump for damage of the enclosure and any leakage in regular intervals, at least two times per year.
Driver	After 5000 operating hours or after ½ year at the latest
Conveying belt	After 5000 operating hours or after ½ year at the latest
Motor/transmission	After 5000 operating hours or after 2 years at the latest
Fittings, connections, inlets	Check in suitable intervals. Replace when damaged with original parts in perfect condition.
Equipotential bonding	Check equipotential bonding between pump enclosure and motor. The equipotential bonding needs to be lower than 0.3 Ohm. Use lock washers for the screws.
Additional components, accessories	During scheduled maintenance work, check any additional components or accessories, e.g. filter installed upstream, separators and gas coolers, if they are in proper working condition.



Components like cable fittings and protective plugs can only be replaced by equal parts with a type examination certificate.

15.1 CHANGING THE PUMP TUBING



Aggressive media residues possible. On disassembly, repairing or cleaning of the hose pump, wear protective glasses and appropriate protective clothing!

**Warning**

If you return the hose pump to M&C customer service for repair, we will ask for information concerning the delivered liquid.

The pump should be cleaned of hazardous or highly aggressive contaminants prior to return shipment.

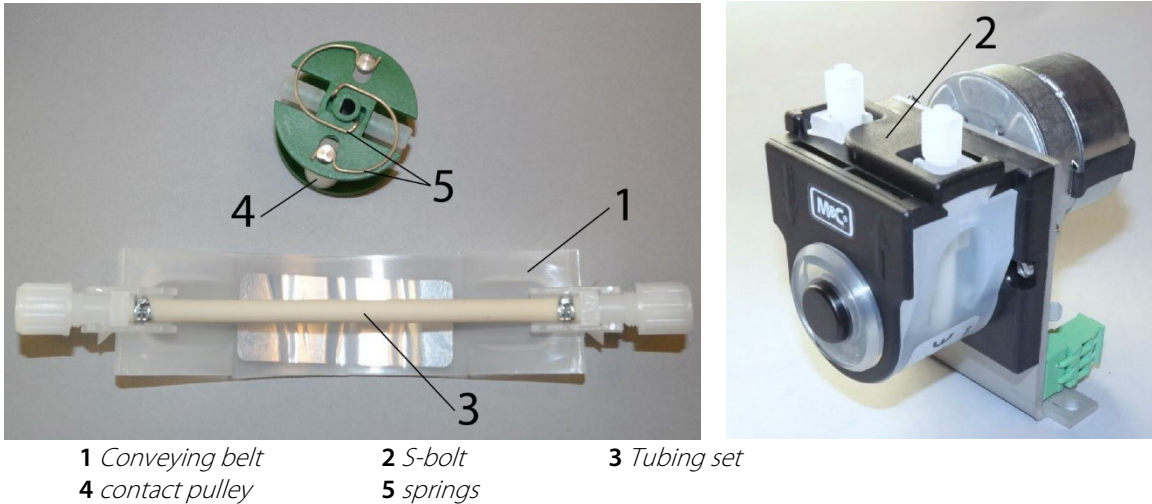
**Figure 8 Changing the pump tubing**

For changing the pump tubing please proceed as follows:

1. Unplug the pump from the mains voltage. The device needs to be voltage free.
2. Open tube connections at the pump;
3. Press conveying belt ① at the recessed grips and turn S-bolt ② clockwise up to limit stop;
4. Take away conveying belt ① and remove the old tubing set ③ from the guides by pulling on the tube connectors;
5. Press the two contact pulleys ④ and check whether the spring pressure is still sufficient, if not, the contact springs have to be changed (see chapter 15.2);
6. Put the new tubing set ③ with the tube connectors into the guides of the conveying belt ① ;

**Warning**

Only the usage of the original tubing set guarantees a proper functionality.
Never lubricate the tube.

Before mounting the pump check all parts for contaminations and clean if necessary.

7. Put the conveying belt ① with the new tubing ③ into the dovetail guide of the pump body;
8. Press conveying belt at the recessed grips and simultaneously turn the S-bolt ② anticlockwise until it snaps;
9. Switch on pump.

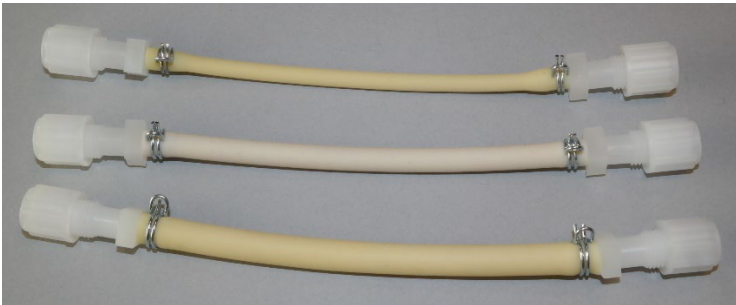

Figure 9 Different pump tube sizes

15.2 CHANGING CONTACT PULLEYS AND SPRINGS



Note

While mounting, make sure that the center of rotation and the driver are aligned. Use genuine spare parts only!

Follow these instructions to change the contact pulley and springs:

- 1. Disconnect the peristaltic pump from power supply
- 2. Unscrew nuts of the pump head (wrench size 5.5) ①

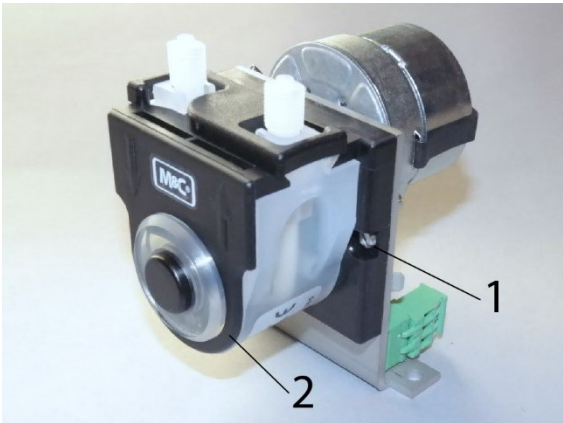

1 Pump head nuts 2 Pump head
 4 Groove 5 Driver (roll carrier)

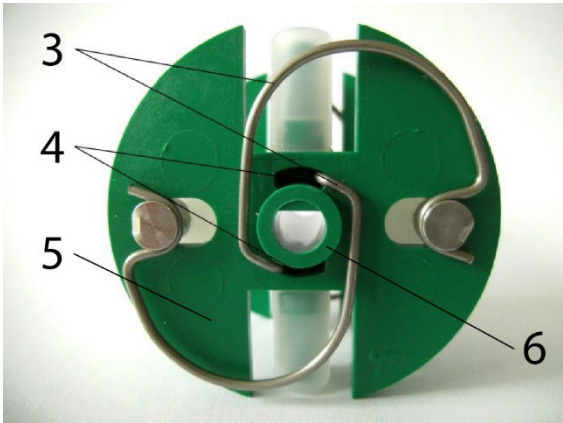

3 Springs
 6 Collar of the shaft bore

Figure 10 Disassembly of pump head and driver

- 3. Remove the pump head ② from the motor shaft
- 4. Now the driver can be removed from the pump head and is ready for maintenance.
- 5. The removal of the springs (4 pcs.) ③ away from the driver is easily possible without the aid of any tools. For this take spring out of the groove ④ near to the shaft bore.

6. Dismount roller axes and change contact pulleys. Take care that axles are not worn out by the springs and have damaged the dent at the axles front end. The axles must be replaced when worn out (see Figure 11).

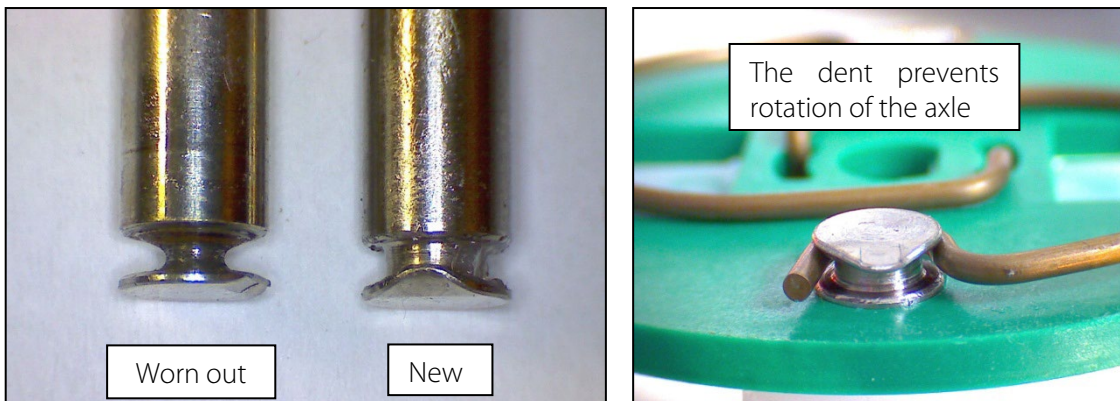

Figure 11 Check of axles and rolls



Note

The springs may come in different colorings. This is not a quality impairment. Make sure to use the right spring strength. This can be identified by the spring wire diameter. The 'standard version for Novoprene pump tubing' (Part No. 90P1010) has a diameter of 1.1 mm and the 'reinforced version for FKM-, Acidflex®- or Masterflex®-tubing' (Part No. 90P1015) has a diameter of 1.2 mm.



Note

Two different types of springs are mounted inside the driver (right and left springs) for the first delivery. When spare springs are ordered, for simplified storage, only one type will be delivered (right spring) which can be used for all four springs and will replace without any problems the initial springs. The replacement springs guarantee full functionality when all four springs are replaced.

- Make sure that contact pulleys roll easily on the axles. After remounting the axles with contact pulley into the driver the spring has to be mounted as shown in Figure 11. Please pay attention to the alignment of the dent.

15.3 REASSEMBLY OF THE DRIVER

Reassemble the driver in reverse order:

1. Insert the roll carrier back into the pump head
2. Push the pump head with the roll carrier onto the motor shaft ②
3. Tighten the nuts of the pump head fastening (SW 5.5) ①.



Note

While mounting, make sure that the center of rotation and the roll carrier (driver) are aligned.
Make sure that the collar of the shaft bore (see Figure 10) faces towards the front of the pump head while mounting the roll carrier.
Use genuine spare parts only!

15.4 CLEANING THE PUMP HEAD

When changing flexible tube or other parts, inspect all parts for dirt before assembling the pump head and clean them if necessary.
We recommend cleaning the parts with a dry cloth. Solvent should not be used, because it can damage the plastics and synthetic rubber parts. Use oil-free compressed air to clean the parts if available.



Aggressive condensate possible!
Media residues in tubing!
Chemical burns caused by aggressive media possible!



Wear protective gloves and protective glasses!
Wear proper protective clothing!

16 REPAIR INFORMATION



Note

When sending the peristaltic pump to M&C customer service for repair, please indicate the type of medium pumped. Before shipping the pump, please remove hazardous or aggressive contaminations from all parts of the pump!

17 PROPER DISPOSAL OF THE DEVICE

At the end of the life cycle of our products, it is important to take care of the appropriate disposal of obsolete electrical and non-electrical devices. To help protect our environment, please follow the rules and regulations of your country regarding recycling and waste management.

18 SPARE PARTS LIST

Wear, tear and replacement part requirements depend on specific operating conditions. The recommended quantities are based on experience and they are not binding.

Peristaltic pump SR25.1, SR25.2-G, SR25.1/EX					
(C) Consumable parts (R) Recommended spare parts (S) Spare parts					
		Recommended quantity being in operation [years]			
Part No.	Indication	C/R/S	1	2	3
90P1007	Hose set ③ SR25.1 with PVDF-tube connectors 4/6mm, standard	C	1	2	4
90P1006	Hose set ③ SR25.1 with PVDF-tube nipples 6mm	C	1	2	4
90P1020	Driver SR25, complete	S	-	1	1
90P1010	1 set (4 pcs) contact springs ⑤ SR25 for driver	R	1	2	2
90P1045	Contact pulley SR25 PVDF ④ for driver	S	2	4	4
90P1050	Conveying belt SR25.1 ①	S	-	1	2
90P1025	S-bolt ② SR25.1	S	-	-	1
01P1000	Peristaltic pump SR25.1, complete 230 V/115 V, 50/60 Hz	R	-	-	1
90P1030	Head peristaltic pump SR25.1, complete without motor and gears	S	-	-	1
90P1031	Head peristaltic pump SR25.2, complete without tube set, motor and gears	S	-	-	1

19 RISK ASSESSMENT

The risk assessment provided in this chapter is intended for all work activities on the product. The hazards can occur in the work steps of assembly, commissioning, maintenance, disassembly and in the event of a product fault. During normal operation, the product is protected by a system cabinet or appropriate covers.

Only qualified personnel is permitted to perform the work. The following minimum knowledge is required for the work:

- Employee instruction provided in process engineering
- Employee instruction provided in electrical engineering
- Detailed knowledge of the instruction manual and the applicable safety regulations

The product complies with the current regulations according to state-of-the-art science and technology. Nevertheless, not all sources of danger can be eliminated while observing technical protective measures. Therefore, the following risk assessment and the description of exposure hazards refer to the work steps mentioned above.

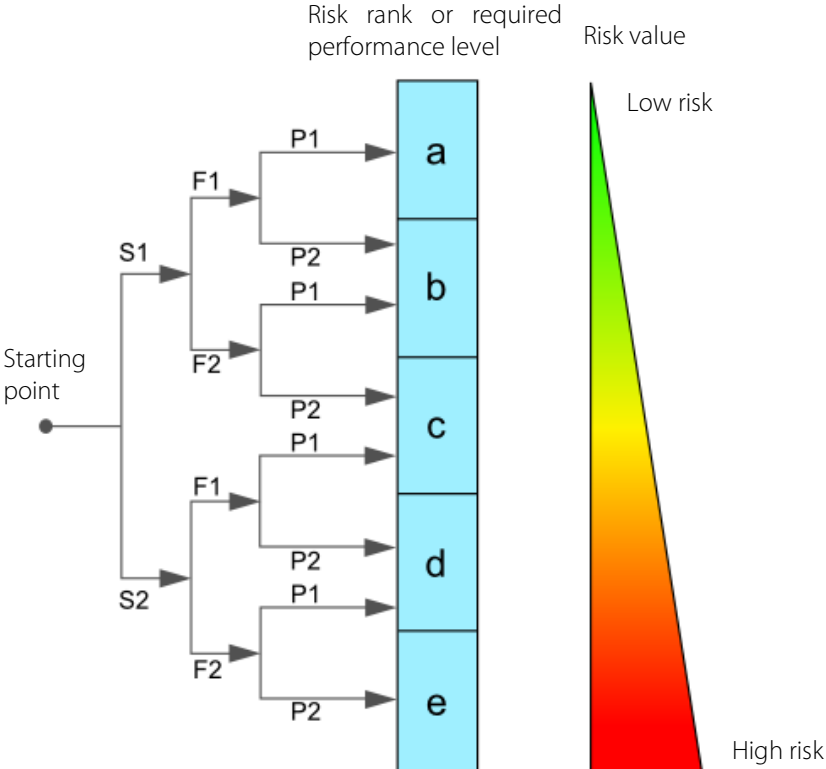

Severity of injury:

S1 = 1 = minor (reversible injury)
S2 = 2 = serious (irreversible injury, death)

Frequency and duration:

F1 = 1 = infrequent or short exposure to hazard
F2 = 2 = frequent (more than once per hour/shift)

Possibility of preventing or limiting the damage

P1 = 1 = possible
P2 = 2 = hardly possible

Figure 12 Overview risk assessment



Aggressive condensate possible

Risk rank group A

Chemical burns due to aggressive media possible!
This applies to all liquids in vessels and in the product.
In general, for electrical and mechanical work on the product, wear personal protective equipment (PPE) in accordance with the risk assessment.



Caution risk of being crushed by rotating parts

Risk rank - group A

The product contains rotating parts. Do not open covers until the device has been switched off.



Caution electric shock

Risk rank group C

When installing high-power systems with nominal voltages of up to 1000 V, the requirements of VDE 0100 and their relevant standards and regulations must be observed!

This also applies to any connected alarm and control circuits. Before opening the products, they must always be disconnected from the power supply.



Gas hazard

Risk rank group A-B-C

The hazard potential mainly depends on the gas to be extracted.

If toxic gases, oxygen displacing or explosive gases are conveyed with the product, an additional risk assessment by the operator is mandatory.

In principle, the gas paths must be purged with inert gas or air before opening the gas-carrying parts.

The escape of potentially harmful gas from the open process connections must be prevented.

The relevant safety regulations must be observed for the media to be conveyed. If necessary, flush the gas-carrying parts with a suitable inert gas. In the event of a gas leakage, the product may only be opened with suitable PPE or with a monitoring system. Furthermore, the work safety regulations of the operator must be observed.

20 APPENDIX

- Spare part drawings SR25.1 and SR25.2
- EC-type examination certificate SR25.1/EX, SR25.2/EX and SR25.3/EX



Further product documentation can be seen and downloaded from our home page:
www.mc-techgroup.com

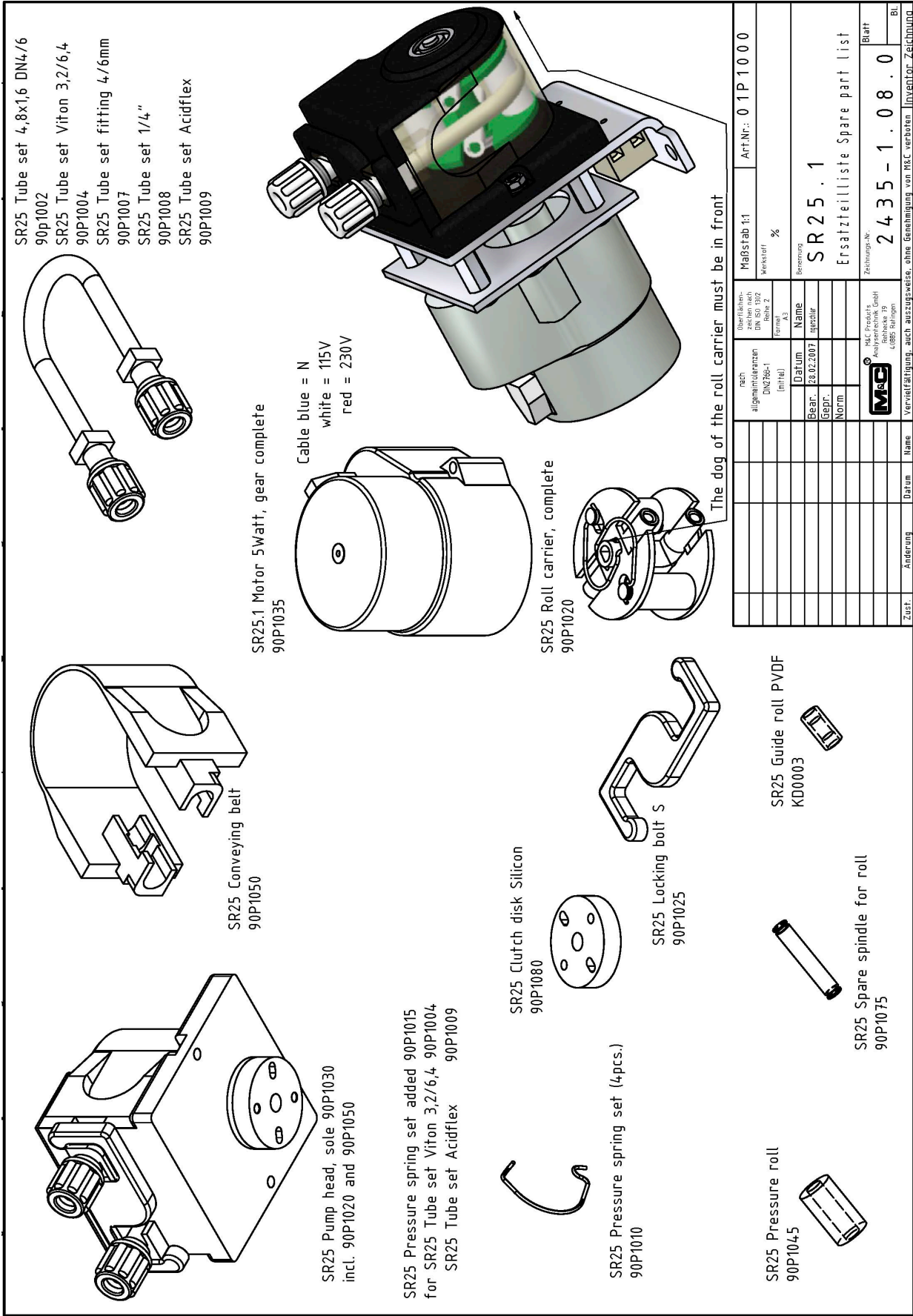



(1) **EC-TYPE EXAMINATION CERTIFICATE**

- (2) Equipment or protective system intended for use in potentially explosive atmospheres - Directive 94/9/EC
- (3) EC-Type Examination Certificate Number: **KEMA 03ATEX2218 X**
- (4) Equipment or protective system: **Pump Types SR25.1 EX, SR25.2 EX and SR25.3 EX**
- (5) Manufacturer: **M&C Products Analysentechnik GmbH**
- (6) Address: **Rehhecke 79, 40885 Ratingen, Germany**

- (7) This equipment or protective system and any acceptable variation thereto is specified in the schedule to this certificate and the documents therein referred to.
- (8) KEMA Quality B.V., notified body number 0344 in accordance with Article 9 of the Council Directive 94/9/EC of 23 March 1994, certifies that this equipment or protective system has been found to comply with the Essential Health and Safety Requirements relating to the design and construction of equipment and protective systems intended for use in potentially explosive atmospheres given in Annex II to the directive.

The examination and test results are recorded in confidential report no. 2010185.

- (9) Compliance with the Essential Health and Safety Requirements has been assured by compliance with:

EN 50014 : 1997

EN 50028 : 1987

- (10) If the sign "X" is placed after the certificate number, it indicates that the equipment or protective system is subject to special conditions for safe use specified in the schedule to this certificate.
- (11) This EC-Type Examination Certificate relates only to the design, examination and tests of the specified equipment or protective system according to the Directive 94/9/EC. Further requirements of the directive apply to the manufacturing process and supply of this equipment or protective system. These are not covered by this certificate.
- (12) The marking of the equipment or protective system shall include the following:

 **II 2 G EEx m II T5**

Arnhem, 7 October 2003
KEMA Quality B.V.



C.G. van Es
Certification Manager

* This Certificate may only be reproduced in its entirety and without any change

KEMA Quality B.V.
Utrechtseweg 310, 6812 AR Arnhem, The Netherlands
P.O. Box 5185, 6802 ED Arnhem, The Netherlands
Telephone +31 26 3 58 20 08, Telefax +31 26 3 52 58 00

ACCREDITED BY THE
DUTCH COUNCIL FOR
ACCREDITATION



Page 1/2

Figure 15 EC-type examination certificate SR25.1/EX, SR25.2/EX and SR25.3/EX



- (13) **SCHEDULE**
 (14) **to EC-Type Examination Certificate KEMA 03ATEX2218 X**

(15) **Description**

Pump Types SR25.1 EX, SR25.2 EX and SR25.3 EX is intended to be used with gas sampling, cooling and analyzing equipment.

Ambient temperature range +5 to +50 °C.

Electrical data

Power supply: 115/230 V, 50-60 Hz, 3,5 VA

Installation instructions

The pump motor shall be mounted in an enclosure, in order to provide mechanical protection for the motor and integral wiring.

Routine tests

Each pump shall be subjected to routine tests according to EN 50028, as follows:

- clause 7.1 – visual check
- clause 7.2 – electric strength test (1500 V, 1 minute, between live parts and grounded parts)
- clause 7.3 – checking electrical data

(16) **Report**

KEMA No. 2010185.

(17) **Special condition for safe use**

The integrally mounted supply cable shall be terminated in a suitable junction box, e.g. in type of explosion protection EEx d or EEx e.

(18) **Essential Health and Safety Requirements**

Covered by the standards listed at (9).

(19) **Test documentation**

dated

- | | |
|------------------------------------|---|
| 1. Description (6 pages) | 13.11.2002 / 08.03.2001 /
28.07.2003 |
| 2. Drawing No. 2435-1.02.0, rev. a | 28.07.2003 |
| 2435-1.03.0, rev. a | 22.09.2003 |
| 2435-4.07.0, rev. a | 28.07.2003 |
| 70-923-148, rev. B | 25.02.2003 |
| 79-294-190, rev. A | 08.01.2003 |