

Gas Conditioning Unit Series PSS[®]

SS-5, SS-5/3

Instruction Manual
Version 1.01.01



**Dear customer,**

Thank you for buying our product. In this manual you will find all necessary information about this M&C product. The information in the manual is fast and easy to find, so you can start using your M&C product right after you have read the manual.

If you have any question regarding the product or the application, please don't hesitate to contact M&C or your M&C authorized distributor. You will find all the addresses in the appendix of this instruction manual.

For additional information about our products, please go to M&C's website www.mc-techgroup.com. There you can find the data sheets and manuals of our products in German and English.

This instruction manual does not claim completeness and may be subject to technical modifications.

© 04/2024 **M&C TechGroup** Germany GmbH. Reproduction of this document or its content is not allowed without permission from **M&C**.

PSS® is a registered trademark.

With the release of this version all older manual versions will no longer be valid. The German instruction manual is the original instruction manual. In case of arbitration only the German wording shall be valid and binding.

Version: 1.01.01

List of Contents

1	General information.....	4
2	Declaration of conformity.....	4
3	Safety instructions	5
3.1	Intended use.....	5
4	Warranty	5
5	Used terms and signal indications.....	6
6	Introduction	8
7	Function of the M&C Jet-Stream heat exchanger	8
8	Application	9
9	Technical data	10
10	Description	11
11	Receipt of goods and storage.....	13
12	Installation instructions	13
13	Supply connections.....	14
13.1	Hose connections.....	14
13.2	Electrical connections	15
14	Preparations for commissioning.....	17
15	Starting	17
16	Closing down	18
17	Maintenance	18
18	Trouble shooting	19
19	Proper disposal of the device	20
20	Spare parts list	21
21	Risk assessment	22
22	Appendix	25

List of Figures

Figure 1	Diagram of the heat exchanger function.....	8
Figure 2	Gas flow diagram of the SS-5 and SS-5/3.....	9
Figure 3	Design of the conditioning and sampling system SS-5 and SS-5/3.....	11
Figure 4	Electrical connections for SS-5 and SS-5/3, 230 V	15
Figure 5	Electrical connections for SS-5 and SS-5/3, 115 V	16
Figure 6	Overview risk assessment.....	23
Figure 7	Circuit diagram SS-5 and SS-5/3, 115 V and 230 V.....	26

HEAD OFFICE

M&C TechGroup Germany GmbH ♦ Rehhecke 79 ♦ 40885 Ratingen ♦ Germany

Telephone: 02102 / 935 – 0

Fax: 02102 / 935 – 111

E - mail: info@mc-techgroup.com

www.mc-techgroup.com

1 GENERAL INFORMATION

The product described in this instruction manual has been built and tested in our production facility.

All M&C products are packed to be shipped safely. To ensure the safe operation and to maintain the safe condition, all instructions and regulations stated in this instruction manual need to be followed. This instruction manual includes all information regarding proper transportation, storage, installation, operation and maintenance of this product by qualified personnel.

Follow all instructions and warnings closely.

Read this manual carefully before commissioning and operating the device. If you have any questions regarding the product or the application, please don't hesitate to contact M&C or your M&C authorized distributor.

2 DECLARATION OF CONFORMITY



The product described in this operating manual complies with the following EU directives:

EMV-Instruction

The requirements of the EU directive 2014/30/EU "Electromagnetic compatibility" are met.

Low Voltage Directive

The requirement of the EU directive 2014/35/EU "Low Voltage Directive" are met.

The compliance with this EU directive has been examined according to DIN EN 61010.

Declaration of conformity

The EU Declaration of conformity can be downloaded from the **M&C** homepage or directly requested from **M&C**.

3 SAFETY INSTRUCTIONS

Follow these basic safety procedures when mounting, starting up or operating this equipment:

Read this operating manual before starting up and use of the equipment. The information and warnings given in this operating manual must be heeded.

Any work on electrical equipment is only to be carried out by trained specialists as per the regulations currently in force.

Attention must be paid to the requirements of VDE 0100 (IEC 364) when setting high-power electrical units with nominal voltages of up to 1000 V, together with the associated standards and stipulations.

Check the details on the type plate to ensure that the equipment is connected to the correct mains voltage.

Protection against touching dangerously high electrical voltages:

Before opening the equipment, it must be switched off and hold no voltages. This also applies to any external control circuits that are connected.

The device is only to be used within the permitted range of temperatures and pressures.

Check that the location is weather protected. It should not be subject to either direct rain or moisture.

The gas conditioning systems SS-5 and SS-5/3 must not be used in hazardous areas.

Installation, maintenance, monitoring and any repairs may only be done by authorized personnel with respect to the relevant stipulations.

3.1 INTENDED USE

The SS-5 and SS-5/3 gas conditioning units are intended for use in general purpose areas (non-hazardous environments). The units can only be operated in compliance with the information in chapter 9 Technical data. You must meet the requirements of the ambient temperature and pressure characteristics in particular.

Do not use this product for any other purpose. Improper use and handling can create hazards and cause damage. For more information, please refer to the safety information in this instruction manual.

4 WARRANTY

In case of a device failure, please contact immediately M&C or your M&C authorized distributor.

We have a warranty period of 12 months from the delivery date. The warranty covers only appropriately used products and does not cover the consumable parts. Please find the complete warranty conditions in our terms and conditions.

The warranty includes a free-of-charge repair in our production facility or the free replacement of the device. If you return a device to M&C, please be sure that it is properly packaged and shipped with protective packaging. The repaired or replaced device will be shipped free of delivery charges to the point of use.

5 USED TERMS AND SIGNAL INDICATIONS



Danger

This means that death, severe physical injuries and/or important material damage **will occur** in case the respective safety measures are not fulfilled.



Warning

This means that death, severe physical injuries and/or important material damage **may occur** in case the respective safety measures are not fulfilled.



Caution

This means that minor physical injuries **may occur** in case the respective safety measures are not fulfilled.

Caution

Without the warning triangle means that a material damage may **occur** in case the respective safety measures are not met.



Note

These are important information about the product or parts of the operating manual which require user's attention.

Qualified Personnel

These are persons with necessary qualification who are familiar with installation, use and maintenance of the product.



High voltages!

Protect yourself and others against damage which might be caused by high voltages.



Toxic!

Acute toxicity (oral, dermal, inhalation)! Toxic when in contact with skin, swallowed or inhaled.



Corrosive!

These substances destroy living tissue and equipment upon contact. Do not breathe vapors; avoid contact with skin and eyes.



Hot surface!

Contact may cause burn! Do not touch!



Caution, risk of being crushed due to rotating parts.

Do not open the device. Use personal protective equipment (PPE).



Wear protective gloves!

Working with chemicals, sharp objects or extremely high temperatures requires wearing protective gloves.



Wear safety glasses!

Protect your eyes while working with chemicals or sharp objects. Wear safety glasses to avoid getting something in your eyes.



Wear protective clothes!

Working with chemicals, sharp objects or extremely high temperatures requires wearing protective clothes.



Use foot protection



Use safety helmet and full protective goggles

6 INTRODUCTION

The unit, which is mounted on an aluminium plate, is a complete sample gas conditioning unit suitable for continuous use and can be easily integrated into analytical systems. This minimizes the effort for the procurement of individual components and small parts as well as the assembly of the individual parts.

The compact design only requires a small amount of space. The system is ready for operation in just a few minutes.

7 FUNCTION OF THE M&C JET-STREAM HEAT EXCHANGER

The **ECP1000** and **ECP3000** gas coolers, specially developed for analysis technology, are designed for maximum flow rates of up to 350 NI/h. They are also installed as system assemblies in the SS-5 and SS-5/3.

Jet-Stream heat exchangers are available in Duran glass, stainless steel (316Ti) and PVDF (polyvinylidene fluoride). The selection of the appropriate heat exchanger material is customer specific. The heat exchangers are easily accessible and easily replaceable in a heat-insulated cooling block. Figure 1 shows a schematic diagram of the heat exchanger function.

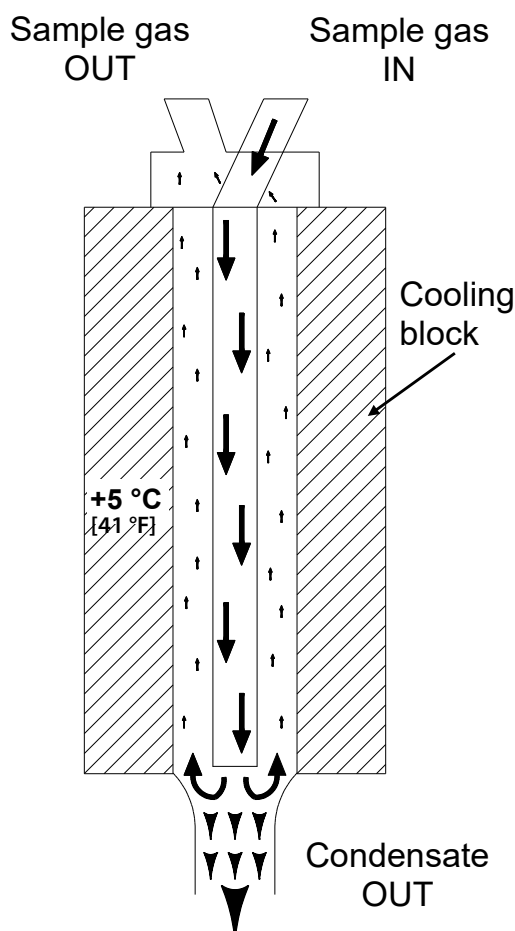

Figure 1 Diagram of the heat exchanger function

8 APPLICATION

The gas conditioning and sampling system is ideally suited for both intermittent and continuous operation.

The components of the system **SS-5...** are intended for "standard use." We also provide a wide range of additional equipment and other components if special measurements are required.

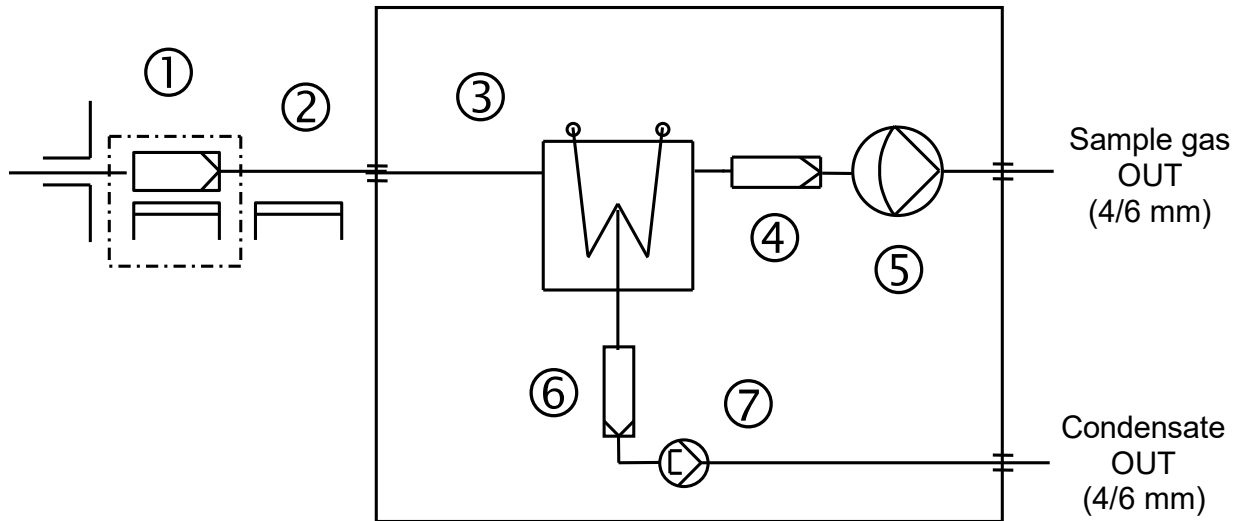

Figure 2 Gas flow diagram of the SS-5 and SS-5/3

- ① Gas sample probe, e.g. SP2000-H
- ② Gas sample line, e.g. heated
- ③ Gas cooler **ECP1000** or **ECP3000**
- ④ Fine filter **FP-2T**, filter element fineness 2 μm
- ⑤ Sample gas diaphragm pump **N3KPE** or **N9KPE**
- ⑥ Pre-filter **PF 2**
- ⑦ Peristaltic pump **SR25.2** for continuous removal of condensate

9 TECHNICAL DATA

Gas Conditioning Type	SS-5	SS-5/3
Part No. version 230 V 50 Hz	03G5000	03G5500
Part No. version 115 V 60 Hz	03G5000a	03G5500a
Sample outlet dew point	Range of adjustment: +2 to +15 °C, factory setting: +5 °C	
Dew point stability	At const. conditions: < ±0.1 °C	
Sample inlet temperature	**Max. 80 °C*, optional: **max. 180 °C with stainless steel bulkhead union	
Sample inlet dew point	**Max. +80 °C	
Gas flow rate	**Max. 150 NI/h	**Max. 350 NI/h
Ambient temperature	**+5 up to +40 °C	
Storage temperature	-25 up to +65 °C	
Pressure	0.7 bar up to 1.4 bar abs.*	
Total cooling power	Max. 50 kJ/h	Max. 90 kJ/h
Number of gas inlets	1	
Number of gas outlets	1* Optional: max. 4	
Medium connections	Tube connections 4/6 mm	
Wetted parts	Stainless steel, glass, PPH, PVC, PVDF, PTFE, Novopren optional: Viton® for gas sample line	
Ready for operation	Approx. 10 min.	
Mains power supply	230 V 50 Hz ±10 % or 115 V 60 Hz ±10 %	
Power consumption	Max. 240 VA Option temperature controller and heated sample line: 230 V max. 1620 VA, 115 V max. 930 VA	
Fuse protection	4 A T (slow fuse), 5 x 20 mm, with option temperature controller and heated sample line: 10 A T (slow fuse), 5 x 20 mm	
Electrical connection	Terminals 4 mm ²	
Device protection rating	IP20 (EN 60529)	
Mounting type	Aluminium mounting plate for wall mounting	
Dimensions (W x H x D)	515 x 385 x 190 mm	
Weight	Approx. 18.5 kg	Approx. 20.0 kg
Electrical equipment standard	EN 61010	
Options		
Temperature controller:	Range of control: 0-200 °C Input : Pt100 230 V, max. 6 A Part No. 01G9055 115 V, max. 6 A Part No. 01G9055a	
Flow meter FM40 (optionally), max. 4	7-70 l/h air, Part No. 01G9070 15-150 l/h air, Part No. 01G9075 25-250 l/h air, Part No. 01G9080 50-500 l/h air, Part No. 01G9085	
Liquid alarm	LA 1S/1.4 Part No. 01G9035	
5-way-ball valve	60750 Part No. 01G9045	

PPH=Polypropylene, PTFE=Polytetrafluoroethylene (Teflon®), PVC=Polyvinyl chloride, PVDF=Polyvinylidenfluoride

* Standard

** Maximum values in technical data must be rated in consideration of total cooling capacity at 25 °C ambient temperature and an outlet dew point of 5 °C.

10 DESCRIPTION

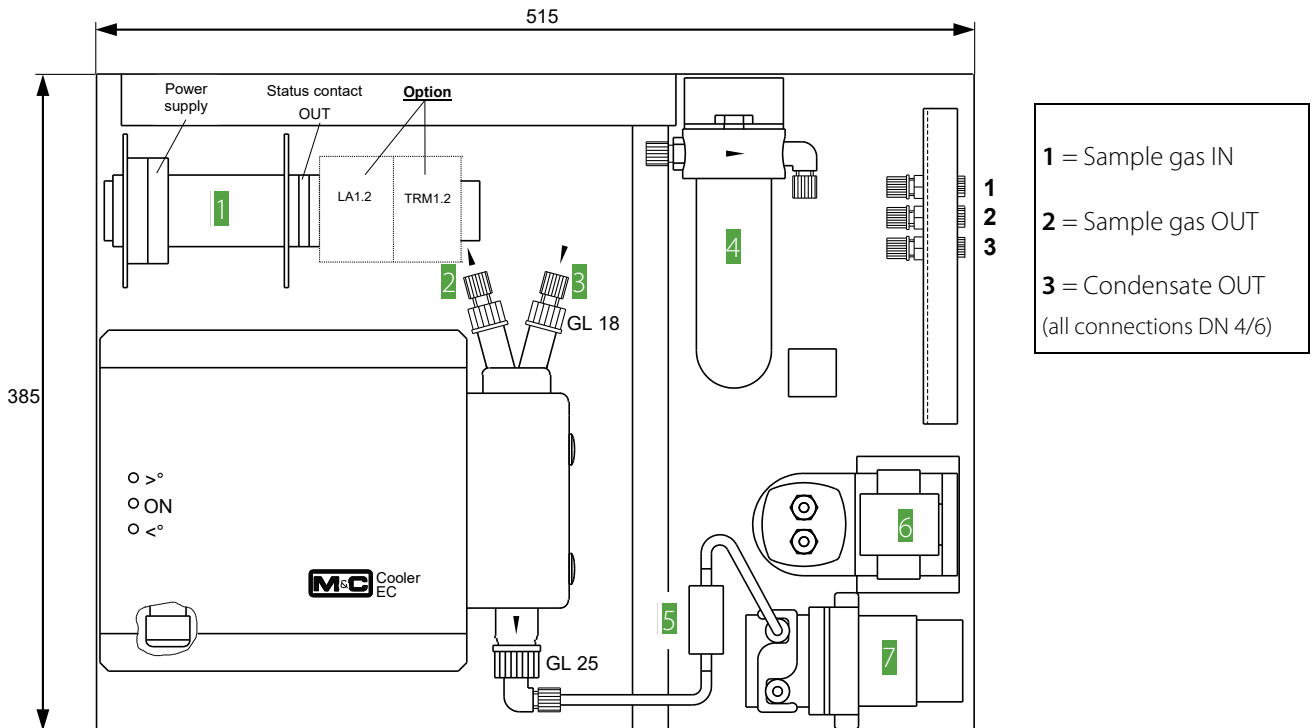

- | | |
|--|--|
| <p>1 Terminal mounting rail</p> <p>2 Cooler, sample gas OUT</p> <p>3 Cooler, sample gas IN</p> <p>4 Fine filter FP-2T</p> <p>5 Pre-filter PF2</p> <p>6 Membrane sample gas pump</p> <p>7 Peristaltic pump SR25.2-W, condensate OUT</p> | <p>2 Cooler, sample gas OUT</p> <p>4 Fine filter FP-2T</p> <p>6 Membrane sample gas pump</p> |
|--|--|

Figure 3 Design of the conditioning and sampling system SS-5 and SS-5/3

All gas conditioning components are mounted on an aluminium plate and are freely accessible.

The installation of a gas cooler and an appropriate diaphragm gas pump **6** will be carried out according to the maximum flow of gas extracted (see instruction manual for individual components). The possible combinations are listed in the following table:

SS-5...	Type of cooler	Max. gas flow [NI/h]	Min. gas flow [NI/h]	Sample gas pump
SS-5	ECP1000	150	60	N3KPE
SS-5/3	ECP3000	350	200	N9KPE

When controlling the sample gas flow rate at the outlet of the conditioning unit (option 'flow meter' or downstream external flow meter), the minimum flow rates (see table) must be strictly adhered to. Falling below the required minimum total flow rate can lead to premature failure of the pump diaphragm due to excessive overpressure.

All gas coolers are equipped with a Duran® glass heat exchanger. Heat exchangers made of PVDF or stainless steel are also available.

The fine filter **FP-2T** (2 µm porosity) **4** installed upstream of the sample gas pump, ensures that the correct amount of solid matter is precipitated.

To protect downstream analyzers, the overtemperature alarm contact (+8 °C) of the cooler automatically switches the sample gas pump **6** on or off.

The resulting condensation is continuously discharged by means of the **SR25.2** **7** peristaltic pump.

A pre-filter, **PF2** **5** has been fitted in the condensation hose in between the heat exchanger and peristaltic pump. This prevents particles in the condensate entering the pump.

The 4/6 mm hose connections (see Figure 3) for the condensate and sample gas line are located on the right-hand side of the gas conditioning unit.

Options

The SS-5 or SS-5/3 sample gas conditioning unit can be equipped with a maximum of four sample gas outlets at the factory. Each sample gas outlet can be adjusted according to the specified volume flow range (see table) by optionally installing a flow meter type FM40 with needle valve. Unused mounting holes for sample gas outlets or flow meters are sealed with blind caps.

To protect the downstream analyzers from a liquid breakthrough and to increase the operational safety of the entire system, we recommend installing a liquid alarm sensor type **LA1S**. For this purpose, the standard **FP-2T** fine filter is replaced by the **FP-2T-D** fine filter with mounted liquid alarm sensor (see appendix). The **LA1.4** evaluation electronics are located on the terminal support rail **1** (Figure 3), in the upper part of the sample gas conditioning unit. It automatically switches off the sample gas pump in the event of a liquid alarm. The alarm is indicated by a red LED. If there is no alarm, a green LED lights up.

The temperature controller 701 (item no.: 01G9055) which is required to control a heated line is mounted on the terminal support rail **1** (Figure 3) at the factory if this option is required.

A 3-way ball valve (01G9046) or a 5-way ball valve (01G9045) can optionally be installed in the gas conditioning inlet for test gas feeding or sample gas switching.

11 RECEIPT OF GOODS AND STORAGE

The gas conditioning and sampling system **SS-5...** is a completely pre-assembled unit. An instruction manual is included in the scope of delivery.

- Please take the gas conditioning system and possible special accessories carefully out of the packaging material immediately after arrival, and compare the goods with the items listed on the delivery note;
- Check the goods for any damage caused during delivery and, if necessary, notify your transport insurance company without delay of any damage discovered.



Note

The equipment should be stored in a protected, frost-free room!

12 INSTALLATION INSTRUCTIONS



Note

The equipment is to be used in a vertical position only. This is the only way to ensure that the condensate is properly separated and drained in the heat exchanger of the cooler.

The gas conditioning unit should be installed away from heat sources and freely ventilated to prevent heat build-up.

Ensure that the conditioning unit is installed on site in a manner that is safe for the personnel.

The compact gas conditioning unit is preferably designed for cabinet installation. If the cabinet is installed outdoors, adequate protection against direct sunlight and moisture must be provided. In winter, the installation location must be frost-free; observe the protection class of the gas conditioning unit.

The supplied spacer bolts (M5, 15 mm) must be used to install the gas conditioning unit.

To ensure the operational safety of the gas conditioning unit and the downstream analyzers and to avoid false alarms, the sample gas conditioning unit must not be used outside the specified temperature range.

Downstream analyzers must always be operated at temperatures well above the specified gas outlet dew point of +5 °C. This prevents subsequent condensation of the gas in the connecting lines to the analyzers.

Unheated gas sampling lines must be installed with a downward gradient to the gas conditioning unit **SS-5...** gas conditioning unit. Condensate pre-separation is then not necessary.



An easily accessible main switch with appropriate labeling must be provided externally.

13 SUPPLY CONNECTIONS

13.1 HOSE CONNECTIONS



Note

Do not switch tube connections; connections are marked accordingly.
After all lines have been connected, the tightness must be checked.

All hose connections are equipped as standard with 4/6 mm compression fittings made of polypropylene (PP) for gas inlet temperatures up to a maximum of 80 °C (see chapter 9). When using heated sample lines and the associated increased gas inlet temperatures up to a maximum of 180 °C, bulkhead fittings made of stainless steel must be selected as an option.

Connecting tubes of dimension 4/6 mm are used as standard.

Install the sample gas tubes and the condensate tube as follows:

1. Remove the union nut from the clamping ring tube fittings by turning it anti-clockwise. The nut should be removed from the thread with great care so as to ensure that the loose sealing ring in the nut is not lost.
2. Place the union nut over the connecting tube.
3. Place the sealing ring over the connecting tube with the thicker bead towards the nut.
4. Place the tube over the nipple on the thread.



Note

The tightness of the connections can only be guaranteed if the connecting hose has a straight rim (hose cutter).

5. The union nut is to be screwed tight by hand.

The hose will no longer be able to slip off and is now compression-proof.

The hoses are to be removed in the reverse order.



Warning

Aggressive condensate possible.

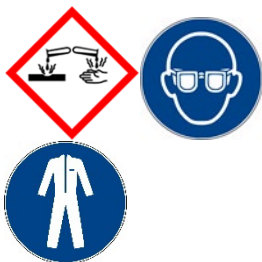

Wear protective glasses and proper protective clothing!

13.2 ELECTRICAL CONNECTIONS



Wrong supply voltage can damage the equipment. When connecting the equipment, make sure that the supply voltage is identical with the information provided on the model type plate!



For the erection of power installations with rated voltages up to 1000V, the requirements of VDE 0100 and relevant standards and specifications must be observed!

An easily accessible main switch with appropriate labeling must be provided externally.

The main circuit is equipped with a fuse corresponding to the nominal current (over current protection); for electrical details see technical data.

The **SS-5** or **SS-5/3** gas conditioning system is available with either 230 V/50 Hz or with 115 V/60 Hz (for circuit diagram see Appendix). The device is protected by a 4 A fuse as standard. The fuse is located on the terminal mounting rail **1** (see Figure 3). In the event that a temperature controller is used in conjunction with a heated sample line, the overload protection level is increased to 10 A.

The electrical connection for the mains is carried out at the terminals 1, 2 and 3 of the mounting rail **1** (see Figure 3). The following figures show the terminal assignment of X1 for 230 V and 115 V, with option LA B1/24. The values in brackets refer to the temperature controller 701.

Terminal X1, 230 V			
	cabinet/PE		
	1	PE	Power in PE
	X1/4	2	Si Power in L
	X1/11	3	Si Power in N
	X1/2	4	E1/X1-1
at option LA B1/24	B1/1	5	M2/L 230V
	B2/L1	6	X2/4
	B2/5 (1)	7	E1/X2-1
	E1/X2-3	8	M1/black
		9	M1/blue
		10	M1/orange
	X1/3	11	M1/white
	X2/2	12	E1/X1-2
	B1/2	13	M2/N 230V
	B2/N	14	X2/3
	B1/3	15	PE E1/X1-3
	X2/PE	16	PE M2/PE
		17	PE M1/PE

Figure 4 Electrical connections for SS-5 and SS-5/3, 230 V

Terminal X1, 115 V

at option LA B1/24	cabinet/PE	1	PE	Power in PE
	X1/4	2	Si	Power in L
	X1/11	3	Si	Power in N
	X1/2	4		E1/X1-1
	B1/1	5		M2/L 115V
	B2/L1	6		X2/4
	B2/5 (1)	7		E1/X2-1
	E1/X2-3	8		M1/black
		9		M1/blue
		10		M1/orange
	X1/3	11		M1/white
	X2/2	12		E1/X1-2
	B1/2	13		M2/N 115V
	B2/N	14		X2/3
	B1/3	15	PE	E1/X1-3
	X2/PE	16	PE	M2/PE
		17	PE	M1/PE

Figure 5 Electrical connections for SS-5 and SS-5/3, 115 V

Option temperature controller 701 for heated sample lines:

A 7-pin connection socket is provided in the side panel for the electrical supply and control of a heated cable with Pt100 sensor or thermocouple. The connection power is max. 6 A, 1380 W for the 230 V version resp. 6 A, 690 W for the 115 V-version.

The maximum length of the heated sample line which can be used is calculated as follows:

$$L(m) = \frac{\text{Max. connection power [W]}}{\text{Power consumption of heated sample line [W/m]}}$$

14 PREPARATIONS FOR COMMISSIONING

Before initial startup, all plant- and process-specific safety measures must be observed. It is mandatory for the operator to complete the enclosed risk assessment of the product.

The gas exposure risk must be assessed by the operator regarding the hazards posed by process and calibration gas and the setup at the installation site (e.g. tubing, system cabinet/container/plant). If the risk assessment reveals increased exposure hazards, further measures are required.

A visible label must be attached to the installation site in accordance with the risk assessment provided by the operator.

15 STARTING

Observe the facility and process-specific safety measures before commissioning.

Carry out the following steps before initial commissioning:

1. Connect the power cable (not included in the scope of delivery) to the terminal mounting rail.
2. Connect the power cable to the mains.



Check the temperature at the temperature controller when operating the sample gas conditioning unit with a heated sample gas line.



3. Option temperature controller 701: Set the desired temperature:

Type 701:

The digital display of the controller shows the actual value of the heated line after switching on the sample gas conditioning. The controller is factory set to 0 °C [32 °F]. Briefly press the *P* key to change the set point. *SP* appears in the display and then the display changes to the adjusted set point. Use the arrow keys to set the desired value. After 60 seconds, the display automatically changes to the actual value.

Type 701 (effective from: September 2020):

After switching on, the display of the controller shows the actual value and the setpoint of the heated line. On delivery, the set point is set to 0 °C [32 °F].

To change the set point, press one of the arrow keys to adjust the desired set point.



The complete instruction manual of the temperature controller 701 is available at www.mc-techgroup.com.

The gas cooler will be operational after approximately 10 minutes. However, if a heated line is connected, the time in which the gas conditioning unit is ready for operation increases to approx. 1 hour. The excess temperature alarm contact located in the cooler, switches the sample gas pump automatically on as soon as the temperature reaches +8 °C.

**Note**

The following minimal gas flow rates have been determined on the basis of the requirements of the maximum pressure on both sides of the gas measuring pumps N3KPE and N9KPE:

N 3 KPE approximately 60 NI/h air,

N 9 KPE approximately 200 NI/h air

Premature damage can be caused to the pump membrane if less than the minimal total amount of flow is extracted as a result of excess pressure.

In the event that long-term measurements are carried out whereby the gas contains a high level of dust, it is necessary to utilise a suitable sample gas probe in order to protect the sample lines from clogging-up.

16 CLOSING DOWN

**Note**

The area in which the equipment is situated when not in use must be kept free of frost at all times.

There are no special regulations to be observed if the gas conditioning and sampling system is to be closed down for a short period of time.

In the case of a long-term closing down, for example after a series of measurements has been completed, it is recommended to backflush the gas conditioning system with ambient air or inert gas. Under normal conditions, the equipment only needs to be backflushed for 3 to 5 minutes. Condensate residue should also be removed from the system.

**Warning**

Aggressive condensate is possible.



Wear protective glasses and proper protective clothing!



17 MAINTENANCE

Observe the facility- and process-specific safety measures before carrying out maintenance work!

**Warning**

Dangerous voltage!

It is necessary to take the equipment off the mains before any assembly, maintenance or repair work is carried out.



The frequency of the maintenance work depends on the operational process and can therefore only be determined in each individual case. Maintenance instructions of the individual components can be found in the instruction manuals for individual components.

All parts to be maintained are easily accessible and installed on the aluminium mounting plate of the sample gas conditioning unit. These are (see Figure 3):

- The filter element of the fine filter **FP-2T** ⁴.



Note

In order to protect downstream analyzers, the wet filter element must always be replaced in the event of a condensate breakthrough.

- The pre-filter for the peristaltic pump **PF2** ⁵. If the condensate contains particle residue, the pre-filter should be replaced at regular intervals. The 'one-way' filter is situated in the suction side of the pump tubing (see figure 2) and can be easily replaced;
- Tubing of the condensate pump **SR25.2** ⁷. These should be checked every six months and, if necessary, replaced;



Note

The complete instruction manual of the SR25.2-W is available at www.mc-techgroup.com.

- Diaphragm of the sample gas pump **N3KPE** or **N9KPE** ⁶. These should be checked every six months and, if necessary, replaced;



Note

The complete instruction manual of N3KPE, N5KPE and N9KPE is available at www.mc-techgroup.com.

18 TROUBLE SHOOTING

The following table aims to point out possible operational problems and offer solutions to such problems (not applicable during the starting procedure).

Problem	Display	Possible Causes	Check/Solution
Gas flow interruption	Upper LED on cooler does not turn on;	No voltage	Check supply voltage with model type plate; OK? Check if mains voltage is applied to X1/2 and X1/3 ; OK? Check the fine fuse on the terminal mounting rail; OK?
		Cooler does not work; Cooler alarm detects 'over temperature'. Cooler turns sample gas pump automatically off.	Ambient temperature too high. OK? Free convection in optional cabinet impaired ⇒ cabinet temperature too high; OK? Cooler error (see instruction manual ECP1000/ECP3000); OK?

Problem	Display	Possible Causes	Check/Solution
Cooler works, but gas flow is interrupted	Middle LED on cooler is green;	Diaphragm pump does not work	Check voltage on terminals X1/8 and X1/11 ; OK?
		Contaminated diaphragm pump	Remove the tubes at the pump head and check; OK? Clean pump if necessary; OK?
		Gas sample probe/sample line clogged or sample line squashed	Remove sample line at gas inlet; Gas flow? Clean contaminated sample line or replace; No gas flow?
		Gas sample line to analyzer clogged or squashed	Disconnect the outlet tube on the analyzer side and check whether sample gas flows at the tube fitting; No gas flow? Clean contaminated lines or replace; Gas flow?
	Alarm LED on the LA electronics is red;	<u>Optional liquid alarm sensor:</u> Sensor turns measuring pump off automatically;	Momentary overloading of the cooler due to excessive amount of condensate; OK? Check tubes for condensate removal; OK? Check tubes of the peristaltic pump (see manual peristaltic pump SR25.2-W); OK? Check peristaltic pump SR25.2-W (see manual peristaltic pump SR25.2-W); OK? Check ECP1000/ECP3000 cooler instruction manual;
		<u>Optional flowmeter(s):</u> Needle valve closed.	Adjust needle valve(s) to the desired flow
Cooler and sample gas pump are running; Condensate in the sample gas line	Middle LED on cooler is green;	Pre-filter PF2 clogged	Remove pre-filter PF2 from condensate line; Pump delivering? Change filter;
		Pump tubing defect	Replace pump tubing (see manual peristaltic pump SR25.2-W); OK?
		Peristaltic pump SR25.2-W does not work	Check peristaltic pump (see manual peristaltic pump SR25.2-W); OK?
		Insufficient drying of sample gas	Check ECP1000/ECP3000 (see ECP1000/ECP3000 cooler instruction manual);
	LED of the LA electronics is green.	Sensor has not turned off pump.	Check the LA sensor function

19 PROPER DISPOSAL OF THE DEVICE

At the end of the service life of our products, it is important to take care of the appropriate disposal of obsolete electrical and non-electrical devices. To help protect our environment, follow the rules and regulations of your country regarding recycling and waste management.

20 SPARE PARTS LIST

Wear, tear and replacement part requirements depend on specific operating conditions.

The recommended quantities are based on experience and are not binding.

For spare parts of components which are not presented in the following list please see the specific instruction manuals or leaflets added in the appendix.

Portable Sampling System Versions SS-5, SS-5/3						
(C) consumable parts, (R) recommended spare parts, (S) spare parts						
		C/R/S	recommended quantity			
			SS-5... being in operation [years]			
			1	2	3	
Fine filter FP-2T:						
90F0002	Filter element F-2T , PTFE, 2µm	C	6	12	20	
90F0040	Viton O-ring, 26 for FP-	R	1	1	1	
90F0056	PVDF filter element clamp F-P	S	-	-	1	
90F0012	Filter body F-120G of glass	R	1	1	1	
Fine filter FP-2T with Option LA1S:						
90F0015	Filter body F-120G-D of glass with GL25 condensate connection thread	R	1	1	1	
90F0020	Union nut GL 25	R	1	1	1	
90F0025	PTFE sealing ring GL 25-12 mm Ø	R	1	1	1	
Peristaltic pump SR25.2:						
90P1007	SR25 pump hose with PVDF tube connectors DN 4/6 mm	C	1	2	4	
Diaphragm pump type N3KPE/KP18; N5KPE/KP18						
90P2100	Square cap type D3, 1/8" female for N3/N5 KPE/KP18, Material: PVDF	S	-	-	1	
90P2120	Diaphragm type S3, for N3/N5 KPE/KP18, Material: Viton®, PTFE coated	C	1	2	3	
90P2111	Valve reed type V3 with O-ring type O3, for N3-N5, 1 piece, material: Viton® (2 pieces required)	C	2	4	6	
90P2105	Intermediate plate type Z3, for N3/N5 KPE/KP18, Material: PVDF	S	-	-	1	
Diaphragm pump type N9KPE/KP18						
90P2200	Square cap type D9, 1/8" female for N9 KPE/KP18, Material: PVDF	S	-	-	1	
90P2220	Diaphragm type S9, for N9 KPE/KP18, Material: Viton®, PTFE coated	C	1	2	3	
90P2211	Valve plate with seal for N9 KPE, 1 pc., material: Viton®. (2 pcs./pump)	C	2	4	6	
90P2205	Intermediate plate type Z9, for N9 KPE/KP18, Material: PVDF	S	-	-	1	

Portable Sampling System Versions SS-5, SS-5/3

(C) consumable parts, (R) recommended spare parts, (S) spare parts

			recommended quantity SS-5... being in operation [years]		
		C/R/S	1	2	3
Option flowmeter FM40:					
90A0015	Flowmeter glass for FM40 range 7-70 NI/h air	S	-	1	1
94F0010	Flowmeter glass for FM40 range 15-150 NI/h air	S	-	1	1
94F0015	Flowmeter glass for FM40 range 25-250 NI/h air	S	-	1	1
94F0020	Flowmeter glass for FM40 range 50-500 NI/h air	S	-	1	1
90A0018	Viton® O-ring 9 for flowmeter glass FM40	R	2	4	6
Diverse:					
90G0006	Pre-filter PF 2 for condensate pump SR25.2	C	5	10	15
90K6030	Fine fuse 4 A T (slow fuse), 5 x 20 mm for SS-5...	R	5	5	5
90G0020	Fine fuse 10 A T (slow fuse), 5 x 20 mm for SS-5... with option temp. controller and heated sample line	R	5	5	5
Hose and hose fittings:					
05V3230	Bulkhead union SV-PP DN 4/6 SS-5 standard PPH = Polypropylene	R	2	2	2
05V3215	Bulkhead union SV-PVDF DN 4/6 SS-5 optional PVDF = Polyvinylidenfluoride	R	2	2	2
05V6500	Sealing ring 4/6 PP see above	R	5	10	10
05V6600	Sealing ring 4/6 PVDF see above	R	5	10	10
05V6505	Union nut M10-4/6 PP see above	R	5	10	10
05V6605	Union nut M10-4/6 PVDF see above	R	5	10	10
01T4000	Hose PVC DN 4/6 (per meter)	S	3	6	9
01T1000	Hose Viton® DN 4/6 (per meter)	S	1	2	3
01T2000	Hose Novoprene DN 3,2/6,4 (per meter)	S	1	2	3
02B1000	Hose PTFE DN 4/6 (per meter)	S	1	2	3
10T1000	Hose cutter	S	1	1	1

21 RISK ASSESSMENT

The risk assessment provided in this chapter is intended for all work activities on the product. The hazards can occur in the work steps of assembly, commissioning, maintenance, disassembly and in the event of a product fault. During normal operation, the product is protected by a system cabinet or appropriate covers.

Only qualified personnel is permitted to perform the work. The following minimum knowledge is required for the work:

- Employee instruction provided in process engineering
- Employee instruction provided in electrical engineering
- Detailed knowledge of the instruction manual and the applicable safety regulations

The product complies with the current regulations according to state-of-the-art science and technology. Nevertheless, not all sources of danger can be eliminated while observing technical protective measures. Therefore, the following risk assessment and the description of exposure hazards refer to the work steps mentioned above.

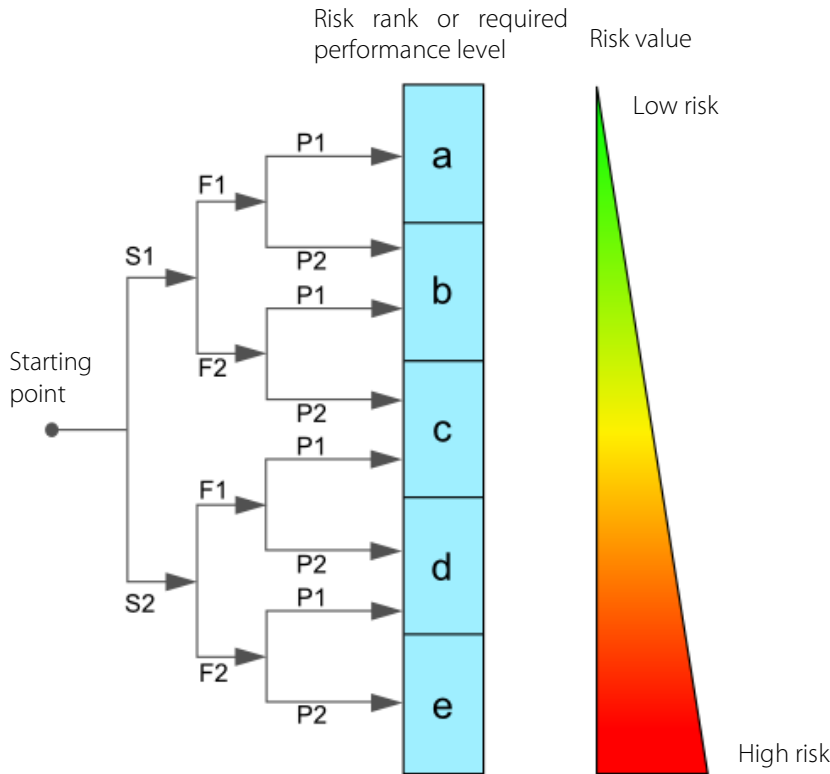

Severity of injury:

S1 = 1 = minor (reversible injury)
 S2 = 2 = serious (irreversible injury, death)

Frequency and duration:

F1 = 1 = infrequent or short exposure to hazard
 F2 = 2 = frequent (more than once per hour/shift)

Possibility of preventing or limiting the damage

P1 = 1 = possible
 P2 = 2 = hardly possible

Figure 6 Overview risk assessment



Aggressive condensate possible

Risk rank group A

Chemical burns due to aggressive media possible!
 This applies to all liquids in vessels and in the product.
 In general, for electrical and mechanical work on the product, wear personal protective equipment (PPE) in accordance with the risk assessment.



Caution risk of being crushed by rotating parts

Risk rank - group A

The product contains rotating parts. Do not open covers until the device has been switched off.



Caution glass

Risk rank - group A

The product contains glass components. In general, for electrical and mechanical work on the product, wear personal protective equipment (PPE) in accordance with the risk assessment.



Caution hot surfaces

Risk rank group A

The temperature inside the product can be higher than $> 60\text{ }^{\circ}\text{C}$.

The hot parts are shielded by mechanical devices. Before opening the products, they must be disconnected from the power supply and a cooling time of more than > 20 minutes must be observed. In general, for electrical and mechanical work on the product, wear personal protective equipment (PPE) in accordance with the risk assessment.



Caution electric shock

Risk rank group C

When installing high-power systems with nominal voltages of up to 1000 V, the requirements of VDE 0100 and their relevant standards and regulations must be observed!

This also applies to any connected alarm and control circuits. Before opening the products, they must always be disconnected from the power supply.



Gas hazard

Risk rank group A-B-C

The hazard potential mainly depends on the gas to be extracted.

If toxic gases, oxygen displacing or explosive gases are conveyed with the product, an additional risk assessment by the operator is mandatory.

In principle, the gas paths must be purged with inert gas or air before opening the gas-carrying parts.

The escape of potentially harmful gas from the open process connections must be prevented.

The relevant safety regulations must be observed for the media to be conveyed. If necessary, flush the gas-carrying parts with a suitable inert gas. In the event of a gas leakage, the product may only be opened with suitable PPE or with a monitoring system. Furthermore, the work safety regulations of the operator must be observed.



Caution crushing hazard

Risk rank group A

The work must be performed by trained personnel only.

This applies to products weighing less than < 40 kg [\approx 88.2 lbs]:

The product can be transported by 1 to 2 person(s). The instructions for appropriate personal protective equipment (PPE) must be observed.

The weight specifications are contained in the technical data of this product.

Furthermore, the work safety regulations of the operator must be observed.

22 APPENDIX

- Circuit diagram **SS-5** and **SS-5/3**



More product documentation is available in our Internet catalogue:
www.mc-techgroup.com

- Instruction manual electric gas cooler **ECP 1000, ECP3000**
- Data sheet for universal filter **FP, FT, FPK, FS, FSS**
- Instruction manual diaphragm pump **Series N**
- Instruction manual for peristaltic pump **SR25.2, SR25.2-G,**
- Instruction manual for Liquid alarm sensor **LA1S** and electronic controller type **LA1.4**
- Data sheet for flow meter **FM40**
- Data sheet for ball valves **L/PV-1**
- Instruction manual for temperature controller **701**

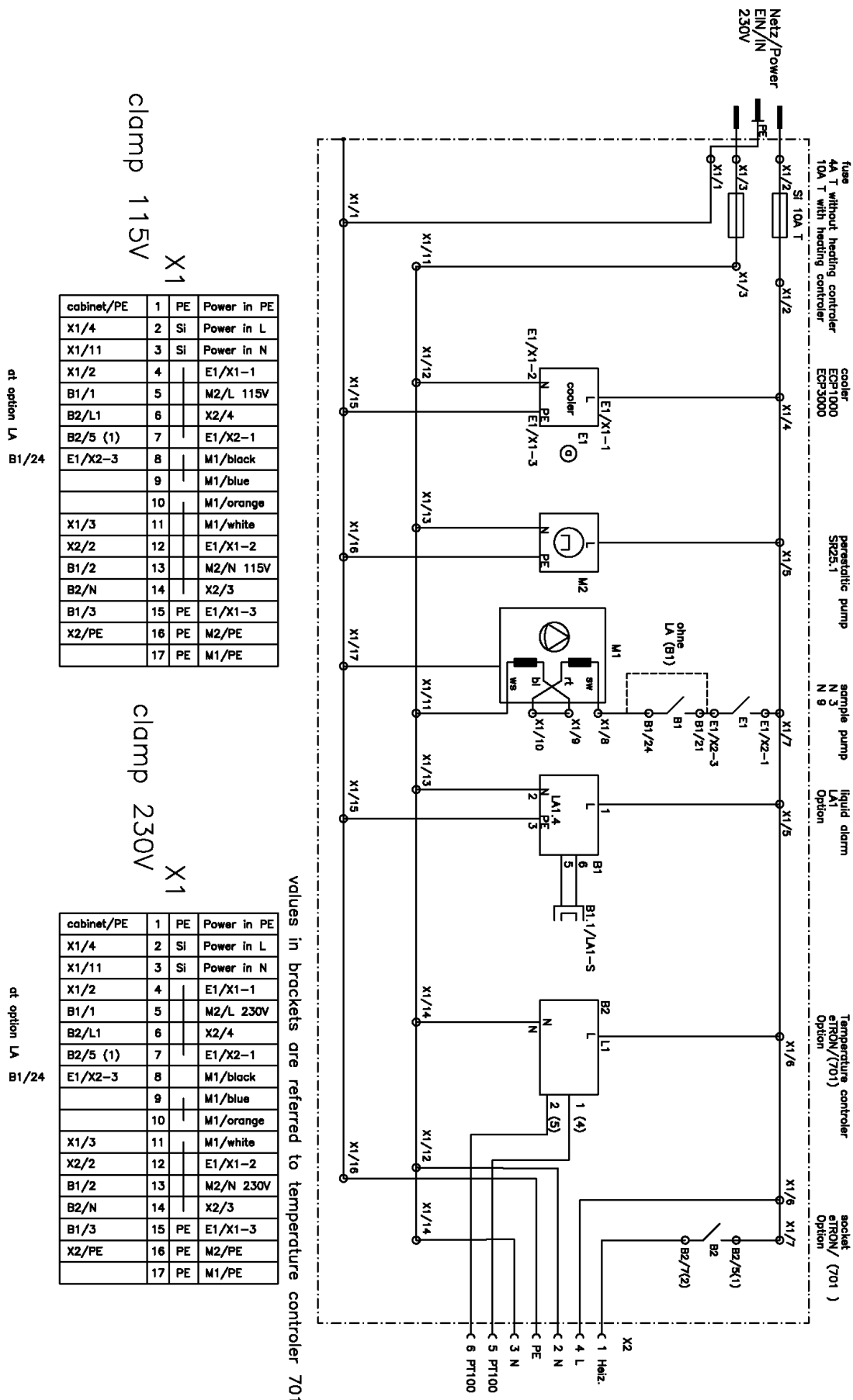

Figure 7 Circuit diagram SS-5 and SS-5/3, 115 V and 230 V