

Electrically Heated Ball and Solenoid Valve Series

V3/2-H, V3/2-H/PE, V3/2-H/EA and MV3/2-H

Instruction Manual
Version 1.01.00



**Dear customer,**

Thank you for buying our product. In this instruction manual you will find all necessary information about this M&C product. The information in the instruction manual is fast and easy to find, so you can start using your M&C product right after you have read the manual.

If you have any question regarding the product or the application, please don't hesitate to contact M&C or your M&C authorized distributor. You will find all the addresses in the appendix of this manual.

For additional information about our products and our company, please go to M&C's website www.mc-techgroup.com. There you will find the data sheets and manuals of our products in German and English.

This Operating Manual does not claim completeness and may be subject to technical modifications.

© 06/2024 **M&C TechGroup** Germany GmbH. Reproduction of this document or its content is not allowed without permission from **M&C**.

With the release of this version all older manual versions will no longer be valid. The German instruction manual is the original instruction manual. In case of arbitration only the German wording shall be valid and binding.

Version: 1.01.00

List of Contents

1	General information	4
2	Declaration of conformity	4
3	Safety instructions	5
3.1	Intended Use.....	5
4	Warranty	5
5	Used terms and signal indications	6
6	Introduction	8
6.1	Serial numbers	8
6.2	Power supply	8
7	Technical Data	9
8	Applications	10
9	Description	10
10	Receipt of Goods and Storage	10
11	Preparation and Installation	10
12	Mounting	11
13	Electrical Connection	11
14	Preparations for commissioning	12
15	Starting	12
16	Maintenance	12
17	Proper disposal of the device	12
18	Spare part list	13
19	Risk assessment	13
20	Appendix	16

List of Illustrations

Figure 1	Overview risk assessment	14
Figure 2	Electrically heated 3-way solenoid valve MV3/2-H	17
Figure 3	Electrically heated 3-way ball valve V3/2-H/PE with 2 off position switch.....	18
Figure 4	Electrically heated 3-way ball valve V3/2-H	19
Figure 5	Electrical connections of electrically heated 3-way ball valve V3/2-H/EA with electrical actuator.....	20
Figure 6	Electrically heated 3-way ball valve V3/2-H/EA with electrical actuator.....	21
Figure 7	Electrically heated 3-way ball valve V3/2-H/EA with electrical actuator and position indication.....	22

Head Office

M&C TechGroup Germany GmbH ♦ Rehhecke 79 ♦ 40885 Ratingen ♦ Germany

Telephone: 02102 / 935 - 0

Fax: 02102 / 935 - 111

E - mail: info@mc-techgroup.com

www.mc-techgroup.com

1 GENERAL INFORMATION

The product described in this manual has been built and tested in our production facility.

All M&C products are packed to be shipped safely. To ensure the safe operation and to maintain the safe condition, all instructions and regulations stated in this manual need to be followed. This manual includes all information regarding proper transportation, storage, installation, operation and maintenance of this product by qualified personnel.

Please follow all instructions and warnings closely.

Please read this manual carefully before commissioning and operating the device. If you have any questions regarding the product or the application, please don't hesitate to contact M&C or your M&C authorized distributor.

2 DECLARATION OF CONFORMITY



The product described in this operating manual complies with the following EU directives:

EMC-Instruction

The requirements of the EU directive 2014/30/EU "Electromagnetic compatibility" are met.

RoHS Directive

The requirements of the RoHS2 ('Restriction of Hazardous Substances 2') directive 2011/65/EU and its annexes are met.

Low Voltage Directive

The requirement of the EU directive 2014/35/EU "Low Voltage Directive" are met.

The compliance with this EU directive has been examined according to DIN EN 61010.

Declaration of conformity

The EU Declaration of conformity can be downloaded from the **M&C** homepage or directly requested from **M&C**.

3 SAFETY INSTRUCTIONS

Please take care of the following basic safety procedures when mounting, starting up or operating this equipment:

Read this operating manual before starting up and use of the equipment. The information and warnings given in this operating manual must be heeded.

Any work on electrical equipment is only to be carried out by trained specialists as per the regulations currently in force.

Attention must be paid to the requirements of VDE 0100 (IEC 364) when setting high-power electrical units with nominal voltages of up to 1000 V, together with the associated standards and stipulations.

Check the details on the type plate to ensure that the equipment is connected to the correct mains voltage.

Protection against touching dangerously high electrical voltages:

Before opening the equipment, it must be switched off and hold no voltages. This also applies to any external control circuits that are connected.

The device is only to be used within the permitted range of temperatures and pressures.

Check that the location is weather-protected. It should not be subject to either direct rain, sun or moisture.

The device must not be used in hazardous areas.

Installation, maintenance, monitoring and any repairs may only be done by authorized personnel with respect to the relevant stipulations.

3.1 Intended Use

The electrically heated ball valves and Solenoid Valve gas conditioning unit is intended for use in general purpose areas (non-hazardous environments). The devices can only be operated in compliance with the information in chapter "Technical data". You must meet the requirements of the ambient temperature and pressure characteristics.

Do not use this product for any other purpose. Improper use and handling can create hazards and cause damage. For more information, please refer to the safety information in this instruction manual.

4 WARRANTY

In case of a device failure, please contact immediately M&C or your M&C authorized distributor.

We have a warranty period of 12 months from the delivery date. The warranty covers only appropriately used products and does not cover the consumable parts. Please find the complete warranty conditions in our terms and conditions.

The warranty includes a free-of-charge repair in our production facility or the free replacement of the device. If you return a device to M&C, please be sure that it is properly packaged and shipped with protective packaging. The repaired or replaced device will be shipped free of delivery charges to the point of use.

5 USED TERMS AND SIGNAL INDICATIONS



DANGER indicates a hazardous situation which, if not avoided, will result in death or serious injury.



WARNING indicates a hazardous situation which, if not avoided, could result in death or serious injury.



CAUTION indicates a hazardous situation which, if not avoided, could result in minor or moderate injury.

Caution

'Caution' indicates that damage to property can occur if the appropriate safety precautions are not observed.



These are important information about the product or parts of the operating manual which require user's attention.

Qualified Personnel

'Qualified personnel' are experts who are familiar with the installation, mounting, commissioning and operation of these types of products.



High voltages!
Protect yourself and others against damage which might be caused by high voltages.



Toxic!
Acute toxicity (oral, dermal, inhalation)! Toxic when in contact with skin, swallowed or inhaled.



Corrosive!
These substances destroy living tissue and equipment upon contact. Do not breathe vapors; avoid contact with skin and eyes.



Hot surface!
Contact may cause burn! Do not touch!



Wear protective gloves!
Working with chemicals, sharp objects or extremely high temperatures requires wearing protective gloves.



Wear safety glasses!

Protect your eyes while working with chemicals or sharp objects. Wear safety glasses to avoid getting something in your eyes.



Wear protective clothes!

Working with chemicals, sharp objects or extremely high temperatures requires wearing protective clothes.



Use foot protection



Use safety helmet and full protective goggles

6 INTRODUCTION

The **M&C** electrically heated 3/2-way ball valves type **V3/2-H...** as well as the solenoid valve **MV3/2-H** are used in heated analysis systems to switch between the following functions:

- sample gas to the analyzer(s),
- calibration gas to the analyzer(s) or
- two sample streams to a common outlet.

6.1 Serial numbers

The nameplates with the serial number are located on the mounting plate of the heated valve.



Note

The gas conditioning system should be stored in a protected frost-free area!

6.2 Power supply

The power supply for the heater of all types of heated valves is 230 V 50 Hz or 115 V 60 Hz.
In case of type **MV3/2-H** the solenoid valve is powered by 24 V DC.

7 TECHNICAL DATA

3/2-Way Valves	V3/2-H	V3/2-H/PE	MV3/2-H
Part number	03V3000(a)	03V3010(a)	03V2000(a)
Position identification	No	Yes	No
Nominal width/C _v	DN 7/1.7		DN 4/0.4
Operating pressure	Max. 30 bar		Max. 2 bar
Sample gas temperature	Max. +180 °C [356 °F]		
Ambient temperature	-25 to +60 °C [-13 to 140 °F]		
Storage temperature	-25 to +80 °C [-13 to 176 °F]		
Gas connections	Tube connectors Ø 6 mm, optional Ø ¼" type Swagelok®		
Temperature controller	Capillary thermostat with high temperature limiter and low temperature alarm; integrated in electrical connection box		
Operating temperature	0 to 180 °C [32 to 356 °F] (set at factory) adjustable		
Dial thermometer	Range 50 to 250 °C [122 to 482 °F]		
Temperature alarm	Alarm point ΔT -30 °C to T _{SET}		
Contact rating	Voltage free change-over contact, 250 V 3 A~, 0.25 A=		
Position identification	No	Voltage free change-over contact, 250 V AC 1 A	No
Power supply	230 V 50 Hz, 115 V 60 Hz (a)		
Power supply solenoid valve	No		24 V DC 15 W
Power consumption	350 VA		
Electrical connections	Terminals 4 mm ² 2 x PG13	Terminals 4 mm ² , 3 x PG13	
Protection / Electrical standard	IP54 (EN 60529) / EN 61010, EN 60519-1		
Dimensions (H x W x D)	320 x 350 x 150 mm [≈ 12.6" x 13.8" x 5.9"]		
Weight	7.5 kg [≈ 16.5 lb]		8 kg [≈ 17.6 lb]
Dead volume	Approx. 5cm ³		
Materials of sample wetted parts	Stainless steel 316Ti, PTFE		Stainless steel 316Ti, FKM, FFKM
Mounting	Wall mounting		

Swagelok® is a registered trademark for tube fittings by Swagelok Company, USA.

8 APPLICATIONS

In analysis technique, often temperatures must be kept above the sample gas dew point. Therefore, it is absolutely necessary to avoid cold spots. In order to ensure this, the temperature regulated **M&C** three-way valves **V3/2-H...** and **MV3/2 H** are used for the cut-off or switching-over of sample gases and test gases up to an operating temperature of 180 °C [356 °F].

9 DESCRIPTION

The **M&C** electrically heated valves are fixed on a mounting plate, decoupled from heat and covered with an insulated enclosure. The heater consists of a heating element with high capacity. The temperature is adjustable on the integrated thermostat up to 180 °C [356 °F] with high temperature limiter and low temperature alarm. The heat insulated enclosure with a bushing for the dial thermometer is equipped with quick acting bentlever closures. The connection box with integrated thermostat is installed outside the enclosure on the mounting plate. Version **V3/2-H/PE** has got an additional connecting box for the contact output of the position identification.

The power supply for the solenoid valves version **MV3/2-H** is 24 V DC and the additional connecting box is installed on the mounting plate. In order to prevent cold spots, the connecting fittings are heated by means of thermal conducting jaws. The electrically heated sample lines type **3/4/5-N/M/H** are fixed with mounting brackets.

10 RECEIPT OF GOODS AND STORAGE

- Please take the heated valve and possible special accessories carefully out of the packaging material immediately after arrival and compare the goods with the items listed on the delivery note!
- Check the goods for any damage caused during delivery and, if necessary, notify your transport insurance company without delay of any damage discovered.



Note

The equipment should be stored in a protected, frost-free room!

11 PREPARATION AND INSTALLATION

Locate the heated 3-way-valves type **V3/2-H...** and **MV3/2-H** in such a way that there is adequate space for removing the cover and connecting the sample lines. Fix the aluminium plate with 4 screws.

Make certain that the heated 3-way-valves are easily accessible so that you can carry out any subsequent maintenance work without trouble.

12 MOUNTING

1. Loosen the four clamps on top and at the bottom.
2. Remove the cover of the heated 3-way-valve type **V3/2-H...** and **MV3/2-H**.
3. Remove the aluminium lid by loosening the two screws.
4. Connect the sample lines to the fittings.



Note

Make sure that the connection is leak proof!

5. Put the aluminium lid back again and screw it.
6. Put the cover of the heated 3-way-valve on top again and close the clamping devices.

13 ELECTRICAL CONNECTION



Warning

When connecting the equipment, please ensure that the supply voltage is identical with the information provided on the type plate.



Note

Attention must be paid to the requirements of IEC 364 (DIN VDE 0100) when setting high-power electrical units with nominal voltages of up to 1000 V, together with the associated standards and stipulations.

A main switch and matching fuse must be provided externally!

The main circuit must be equipped with a fuse corresponding to the nominal current (over current protection), for electrical details see technical data.

1. Remove the lid of the electrical connection box. The electrical connection layout is located in the lid. Insert the mains cable (min. 3 x 1.5 mm²) through the cable gland and connect to the appropriate terminals.
2. Insert the signal cable through the cable gland and connect to the appropriate terminals. Screw lid back on.

14 PREPARATIONS FOR COMMISSIONING

Before initial startup, all plant- and process-specific safety measures must be observed. It is mandatory for the operator to complete the enclosed risk assessment of the product.

The gas exposure risk must be assessed by the operator with regard to the hazards posed by process and calibration gas and the setup at the installation site (e.g. tubing, system cabinet/container/plant). If the risk assessment reveals increased exposure hazards, further measures are required.

A visible label must be attached to the installation site in accordance with the risk assessment provided by the operator.

15 STARTING



Warning



Before starting up the device check whether the mains power supply voltage corresponds with the information stated on the valves type plate.

Switch on mains power supply.

The total heating-up time is approximately 30 min. The heated 3-way-valves type **V3/2-H...** and **MV3/2-H** are then ready for operation

16 MAINTENANCE

No special maintenance necessary.

17 PROPER DISPOSAL OF THE DEVICE

At the end of the life cycle of our products, it is important to take care of the appropriate disposal of obsolete electrical and non-electrical devices. To help protect our environment, please follow the rules and regulations of your country regarding recycling and waste management.

18 SPARE PART LIST

Wear, tear and replacement part requirements depend on specific operating conditions. The recommended quantities are based on experience and they are not binding.

Heated 3-way-valves type V3/2-H... and MV3/2-H					
(C) Consumable parts					
(R) Recommended spare parts					
(S) Spare parts					
					Recommended quantity being in operation [years]
Part No.	Indication	C/R/S	1	2	3
90F3000	Cartridge heater element for filter H1/H2, L = 100 mm, 230 V AC/350 W	R	1	1	1
90F3010	Cartridge heater element for filter H1/H2, L = 100 mm, 115 V AC/350 W	R	1	1	1
90P5020	Thermostat (0 to 180 °C [32 to 356 °F]), with high-temperature limiter and low-temperature alarm for MP26-H1, FT-H2,T6-H1	R	1	1	1

19 RISK ASSESSMENT

The risk assessment provided in this chapter is intended for all work activities on the product. The hazards can occur in the work steps of assembly, commissioning, maintenance, disassembly and in the event of a product fault. During normal operation, the product is protected by a system cabinet or appropriate covers. Only qualified personnel is permitted to perform the work. The following minimum knowledge is required for the work:

- Employee instruction provided in process engineering
- Employee instruction provided in electrical engineering
- Detailed knowledge of the instruction manual and the applicable safety regulations

The product complies with the current regulations according to state-of-the-art science and technology. Nevertheless, not all sources of danger can be eliminated while observing technical protective measures. Therefore, the following risk assessment and the description of exposure hazards refer to the work steps mentioned above.

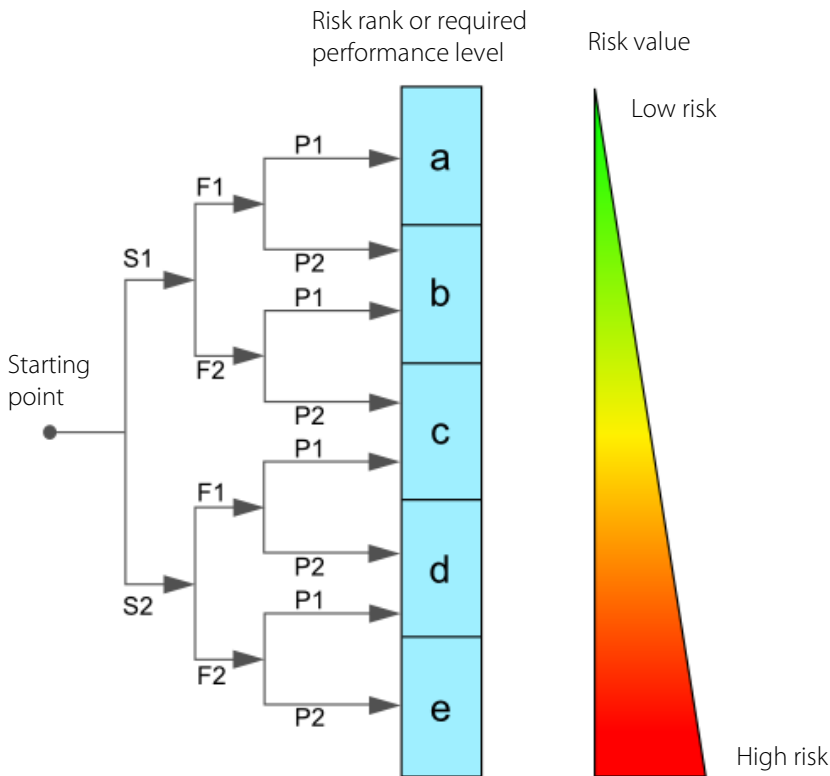

Severity of injury:

S1 = 1 = minor (reversible injury)
 S2 = 2 = serious (irreversible injury, death)

Frequency and duration:

F1 = 1 = infrequent or short exposure to hazard
 F2 = 2 = frequent (more than once per hour/shift)

Possibility of preventing or limiting the damage

P1 = 1 = possible
 P2 = 2 = hardly possible

Figure 1 Overview risk assessment



Aggressive condensate possible

Risk rank group A

Chemical burns due to aggressive media possible!
 This applies to all liquids in vessels and in the product.
 In general, for electrical and mechanical work on the product, wear personal protective equipment (PPE) in accordance with the risk assessment.



Caution hot surfaces

Risk rank group A

The temperature inside the product can be higher than $> 180\text{ }^{\circ}\text{C}$.

The hot parts are shielded by mechanical devices. Before opening the products, they must be disconnected from the power supply and a cooling time of more than > 180 minutes must be observed. In general, for electrical and mechanical work on the product, wear personal protective equipment (PPE) in accordance with the risk assessment.



Caution electric shock

Risk rank group C

When installing high-power systems with nominal voltages of up to 1000 V, the requirements of VDE 0100 and their relevant standards and regulations must be observed!

This also applies to any connected alarm and control circuits. Before opening the products, they must always be disconnected from the power supply.



Gas hazard

Risk rank group A-B-C

The hazard potential mainly depends on the gas to be extracted.

If toxic gases, oxygen displacing or explosive gases are conveyed with the product, an additional risk assessment by the operator is mandatory.

In principle, the gas paths must be purged with inert gas or air before opening the gas-carrying parts.

The escape of potentially harmful gas from the open process connections must be prevented.

The relevant safety regulations must be observed for the media to be conveyed. If necessary, flush the gas-carrying parts with a suitable inert gas. In the event of a gas leakage, the product may only be opened with suitable PPE or with a monitoring system. Furthermore, the work safety regulations of the operator must be observed.



Caution crushing hazard

Risk rank group A

The work must be performed by trained personnel only.

This applies to products weighing less than $< 40\text{ kg}$ [$\approx 88.2\text{ lbs}$]:

The product can be transported by 1 to 2 person(s). The instructions for appropriate personal protective equipment (PPE) must be observed.

The weight specifications are contained in the technical data of this product.

Furthermore, the work safety regulations of the operator must be observed.

20 APPENDIX

Drawings:

- Electrically heated 3-way solenoid valve MV3/2-H
- Electrically heated 3-way ball valve V3/2-H/PE with 2 off position switch
- Electrically heated 3-way ball valve V3/2-H
- Electrical connections of the electrically heated 3-way ball valve V3/2-H/EA with electrical actuator
- Electrically heated 3-way ball valve V3/2-H/EA with electrical actuator
- Electrically heated 3-way ball valve V3/2-H/EA with electrical actuator and position indication



Further product documentation can be seen and downloaded from our home page:
www.mc-techgroup.com

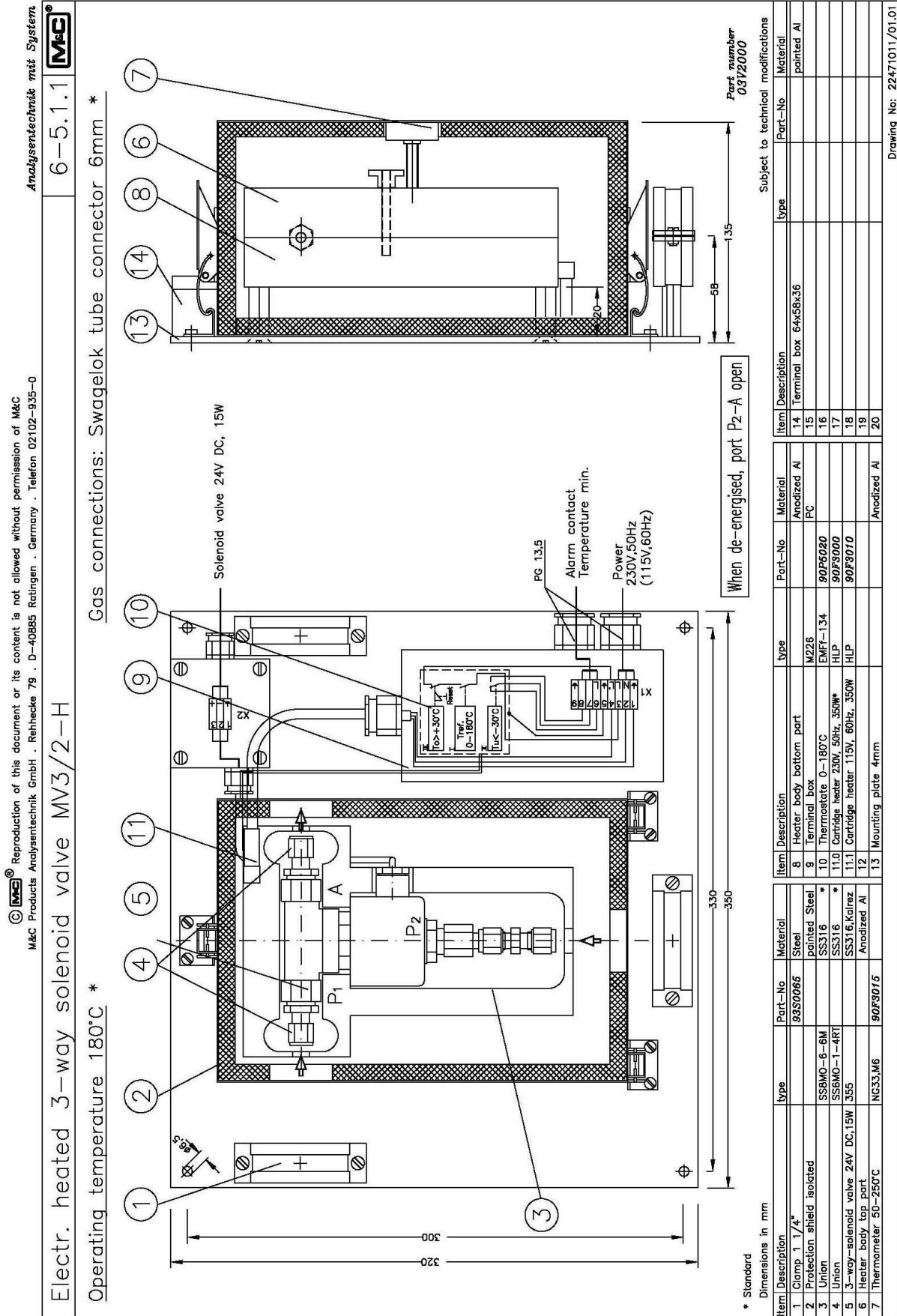

Figure 2 Electrically heated 3-way solenoid valve MV3/2-H

Reproduction of this document or its content is not allowed without permission of M&C
 M&C Products Analysentechnik GmbH, Reihhecke 79, D-40885 Ratingen, Germany, Tel.: 02102-935-0

Analysentechnik mit System

Electr. heated 3-way ball valve V3/2-H/PE incl. 2 off position switch

6-5.1.6

Operating temperature 180°C *

Gas connections: Swagelok tube connector 6mm *

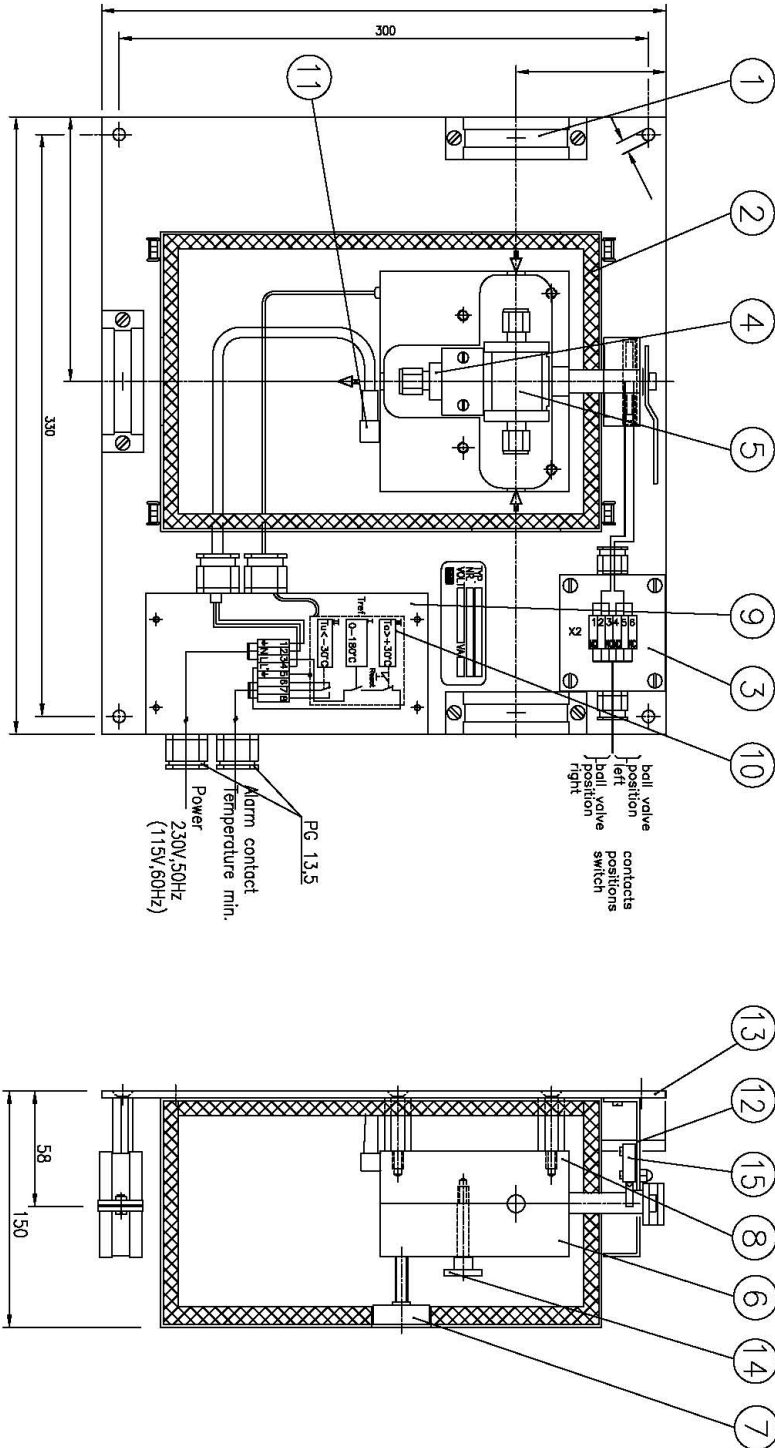

Item Description	type	Part-No	Material
1 Clamp 1 1/4"		83S0055	Steel
2 Protection shield isolated			pointed Steel
3 Terminal box		SS6MO-1-4	SS316
4 Union DN 4/6 *		09P2005	SS316, PTFE
5 3-way-ball valve		SS62-X1-F-4	Anodized Al
6 Heater body top part		NG33.M6	
7 Thermometer 50-250°C		90F9015	

* Standard
 Dimensions in mm

Item Description	type	Part-No	Material
8 Heater body bottom part			Anodized Al
9 Terminal box	M228	90P5020	PC
10 Thermostat 0-180°C	EMF-134	90F9000	H1P
11.0 Cartridge heater 230V, 50Hz, 350W*	H1P	90F9000	H1P
11.1 Cartridge heater 115V, 60Hz, 350W	H1P	90F9010	H1P
12 Square			Anodized Al
13 Mounting plate Arm			Anodized Al

Subject to technical modifications

Item Description	type	Part-No	Material
14 Knurl nut M6			Steel, galvan.
15 Position switch 250V AC, 10(1,5)A	DC2		
16			
17			
18			
19			
20			

Part number
 08V3010

Drawing No: 22481021/02.01

Figure 3 Electrically heated 3-way ball valve V3/2-H/PE with 2 off position switch

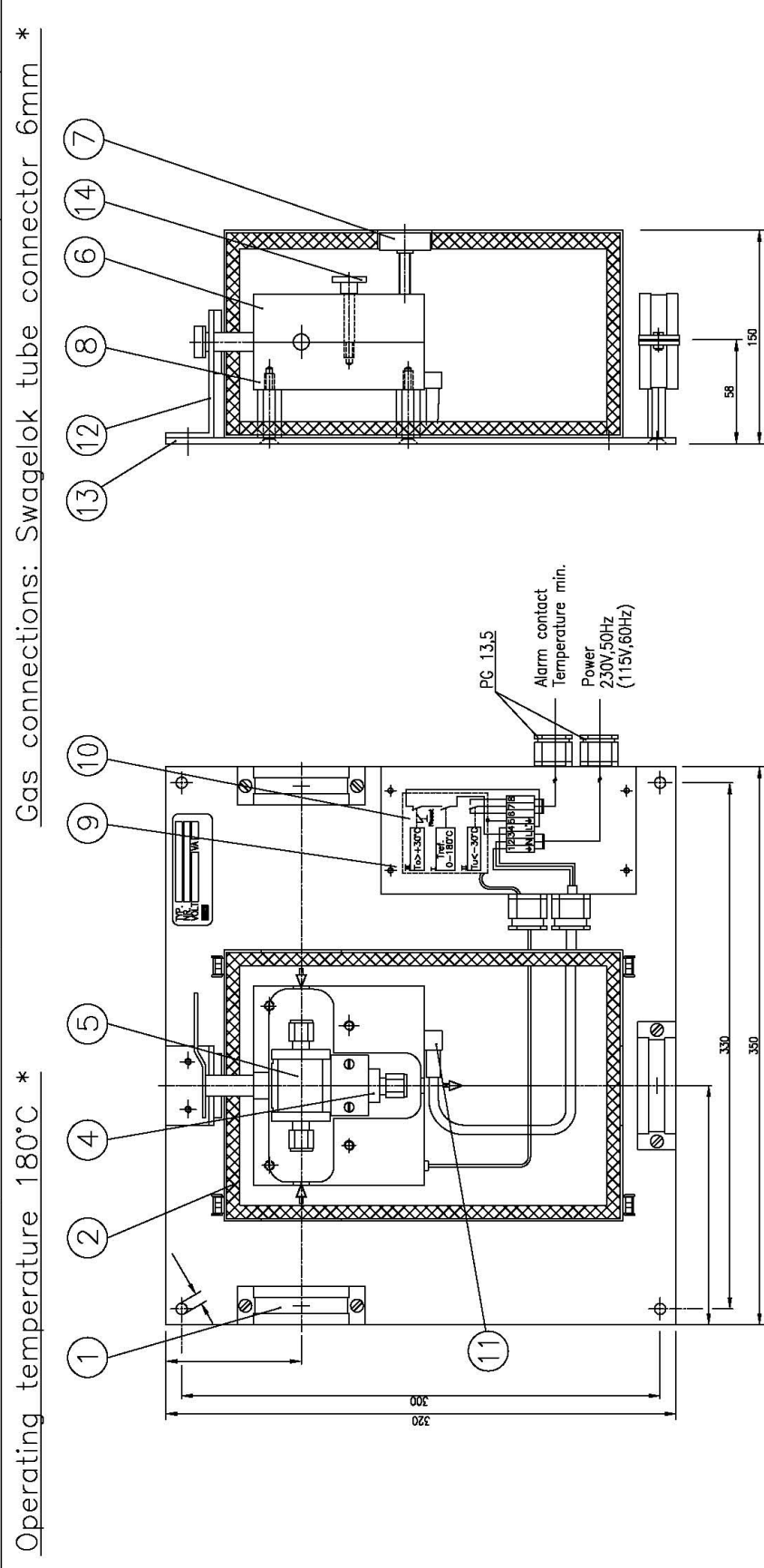

Part number 09V3000

Item		Description		Material	Part-No	Type	Subject to technical modifications	
Item	Description	Material	Part-No	Type	Description	Material	Part-No	Material
1	Clamp 1 1/4"	Steel	93S0065					
2	Protection shield isolated	Painted Steel						
3	Union DN 4/6 *	SS316	09V2005					
4	3-way-ball valve	SS316, PTFE	SS62-XI-F4					
5	Heater body top part	Anodized Al	90F3015					
6	Heater body bottom part	Anodized Al	90F3020					
7	Thermometer 50-250°C	PC	90F3010					
8	Heater body bottom part	Anodized Al	90F3010					
9	Terminal box	PC	90F3000					
10	Thermostat 0-180°C		90F3000					
11	Cartridge heater 230V, 50Hz, 350W		90F3000					
12	Square	Anodized Al	90F3010					
13	Mounting plate 4mm	Anodized Al	90F3010					
14	Krutt nut M8							

* Standard

Dimensions in mm

Drawing No: 22461011/02.01

Figure 4 Electrically heated 3-way ball valve V3/2-H

Electric, heated 3 way ball valve V3/2-H/EA, with electr. actuator

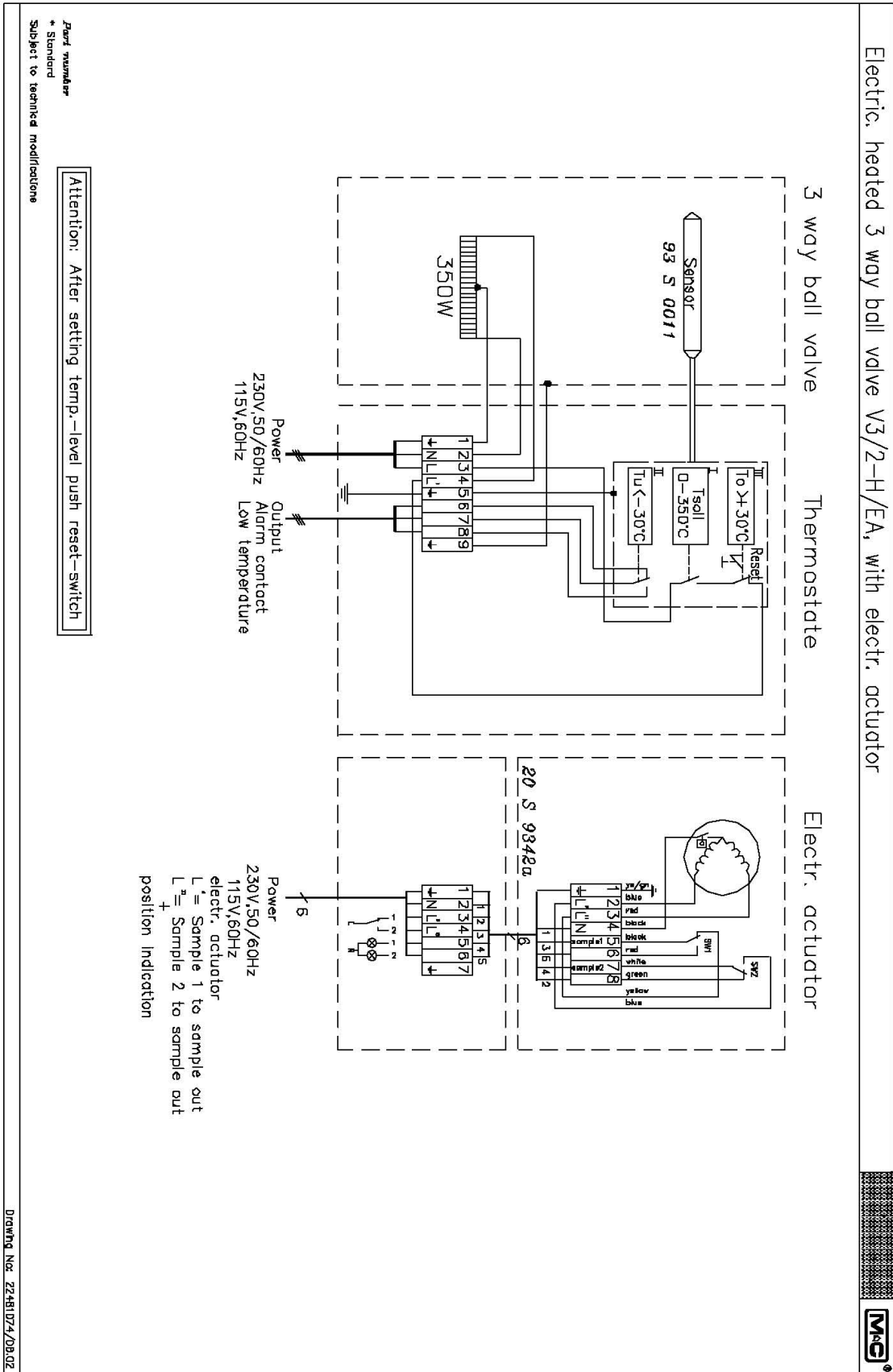

Figure 5 Electrical connections of electrically heated 3-way ball valve V3/2-H/EA with electrical actuator

Analyse- und Messtechnik mit Systemen

© M&C® Reproduction of this document or its content is not allowed without permission of M&C
 M&C Products Analysetechnik GmbH, Rehrheide 79, D-40885 Ratingen, Germany, Tel.: 021 02-935-0

Electr. heated 3-way ball valve V3/2-H/EA with electr. actuator

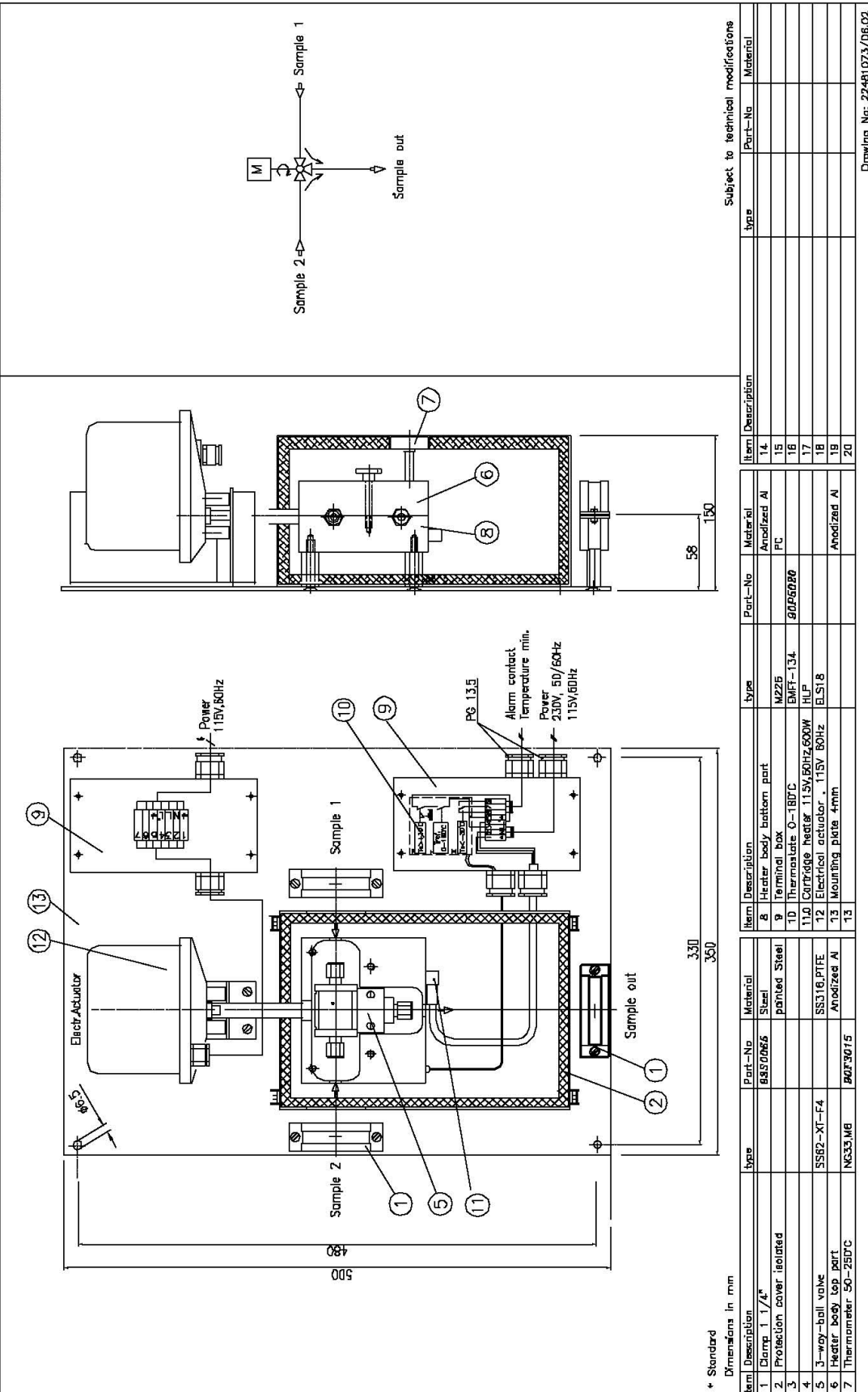
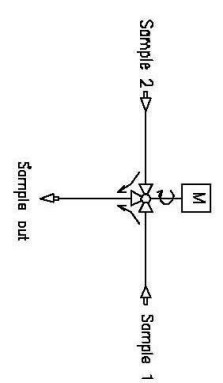
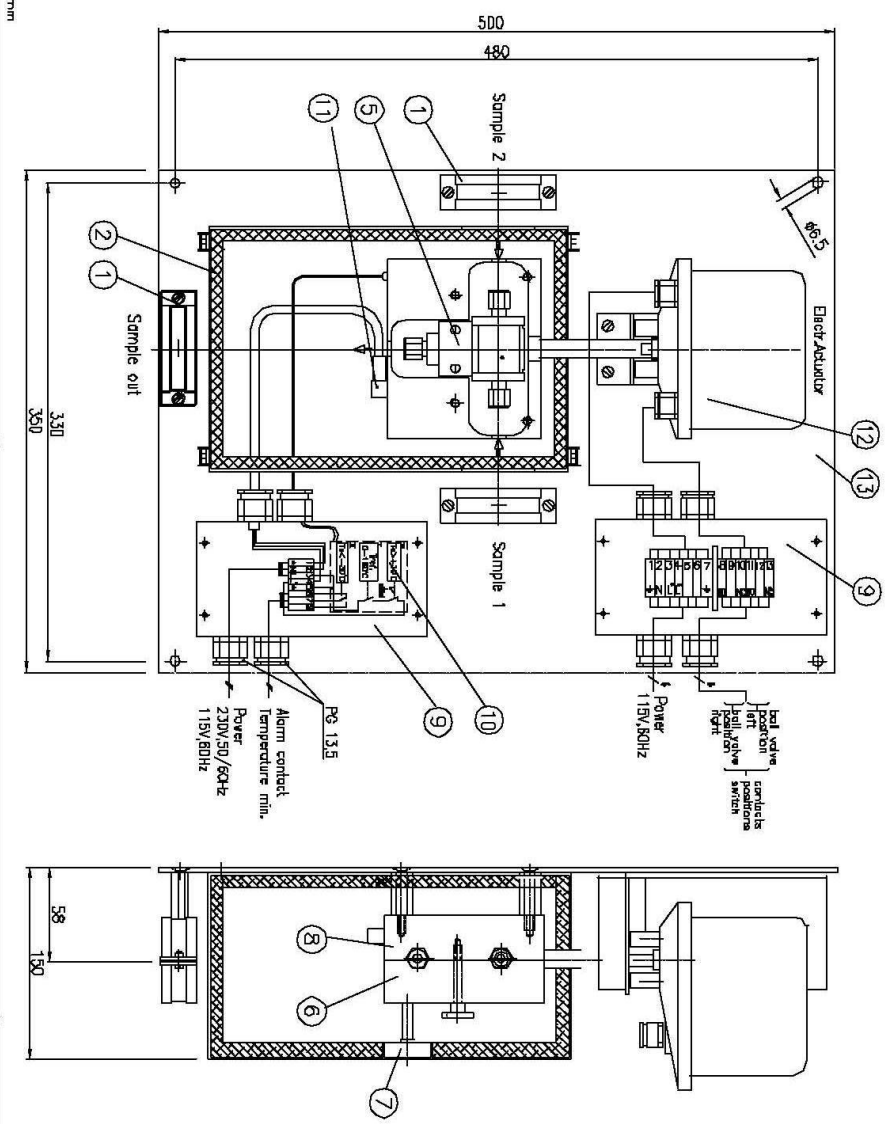

Figure 6 Electrically heated 3-way ball valve V3/2-H/EA with electrical actuator

Electr. heated 3-way ball valve V3/2-H/EA with electr. actuator and position indication

© M&C® Reproduction of this document or its content is not allowed without permission of M&C
 M&C Products Analytische GmbH Reihensee 79, D-40885 Ratingen, Germany, Tel.: 02102-935-0

Analytische GmbH System



Item	Description	type	Part-Nr.	Material	Item	Description	type	Part-Nr.	Material
1	Flange 1 1/4"		64370065	Steel	14				
2	Protection cover isolated			Painted Steel	15				
3					16				
4					17				
5	3-way-ball valve		SS82-XI-FA	SS316,PTFE	18				
6	Heater body top part		NS33 MB	Anodized Al	19				
7	Thermometer 50-250°C		BAT3015	Anodized Al	20				

Item	Description	type	Part-Nr.	Material
8	Heater body bottom part			Anodized Al
9	Terminal box	M225		PC
10	Thermostat 0-180°C	BMF-134		01050780
11	Control heater 115V,80Hz,350W	HLP		
12	Electrical actuator 115V 80Hz*	E 25		
12.1	Position switches		0156848	
13	Mounting plate 4mm			Anodized Al

Subject to technical modifications

Drawing No: 22481075/01.04

Figure 7 Electrically heated 3-way ball valve V3/2-H/EA with electrical actuator and position indication