



SENSOTOX 2

User Manual V8.7

READ THE MANUAL BEFORE USING



This manual should be carefully read by those who have or will have responsibility for install, use, maintenance or repair of the product.



This product will perform properly only if used, maintained and repaired in accordance with the manufacturer's instructions.

CAUTION



Disconnect the power before removing the sensor. Remove the cover and the sensor from the unit only if the work area is known not to be dangerous.

WARNING



Calibration of all new unit should be checked by exposing the sensors to a known gas concentration before putting the instrument into service. For maximum safety, the accuracy of reading of the Sensotox2 should be checked every 6 months.



This equipment has not been evaluating against the essential safety requirements form the points 1.5.5, 1.5.6 & 1.5.7 from Annex 2 of Directive 2014/34/UE relative to measuring instruments.



Use only Sensotran original replacement parts

Contents

1.	INTRODUCTION.....	2
1.1	TECHNICAL SPECIFICATIONS.....	5
	Sensotox2 EC specifications.....	5
	Sensotox2 IR specifications	6
	Sensotox2 LEL specifications.....	7
	Sensotox2 PID Specifications.....	8
2.	OPERATION.....	9
2.1	PHYSICAL DESCRIPTION.....	10
2.2	Installation	11
	2.2.1 Installing	11
	2.2.2 Uninstalling.....	12
	2.2.3 Wiring	12
	2.2.4 Installing the unit.....	13
	2.2.5 Earthing instructions.....	14
	External earth connection	14
	Internal earth.....	14
2.3	Display and User Interface	15
	2.3.1 User interface	15
	2.3.2 Magnetic key	16
	2.3.3 Using the magnet	16
	2.3.4 Starting up the unit.....	17
	2.3.5 Display readout.....	17
	2.3.6 Alarm contacts.....	18
2.4	Calibration	19
	2.4.1 Calibration	20
	I - Zero calibration.....	20
	II - Span calibration.....	22
2.5	Sensor replacement	24
2.6	Advanced Menu.....	25
3.	Troubleshooting.....	31
4.	MODBUS/RS-485.....	32

1. INTRODUCTION

Sensotox 2 EC uses an electrochemical sensor to detect oxygen and toxic gases. It works with voltages from 12 to 36 V dc with an analogue (4-20 mA) or digital (RS-485, ModBus) output. Sensotox2 is equipped with flameproof enclosure, and this may be blind or have a window with a display for reading the gas concentration, status LEDs and magnetic keys for configuration.

Sensotox 2 IR uses a non-dispersive infrared sensor to detect combustible gases, carbon dioxide and other gases. It works with voltages from 12 to 36 V dc with an analogue (4-20 mA) or digital (RS-485, ModBus) output. Sensotox2 is equipped with flameproof enclosure, and this may be blind or have a window with a display for reading the gas concentration, status LEDs and magnetic keys for configuration.

Sensotox 2 LEL uses a catalytic sensor with high resistance to contaminants for detecting combustible gases (LEL). It works with voltages from 12 to 36 V dc with an analogue (4-20 mA) or digital (RS-485, ModBus) output. Sensotox2 is equipped with flameproof enclosure, and this may be blind or have a window with a display for reading the gas concentration, status LEDs and magnetic keys for configuration.

Sensotox 2 PID uses a sensor to detect volatile organic compounds (VOCs). It works with voltages from 12 to 36 V dc with an analogue (4-20 mA) or digital (RS-485, ModBus) output. Sensotox2 is equipped with flameproof enclosure, and this may be blind or have a window with a display for reading the gas concentration, status LEDs and magnetic keys for configuration.

Hazardous Area Approval

ATEX: II 2G Ex db IIC T6 Gb -40° C < Tamb < +60° C

Sensotox 2 marking example

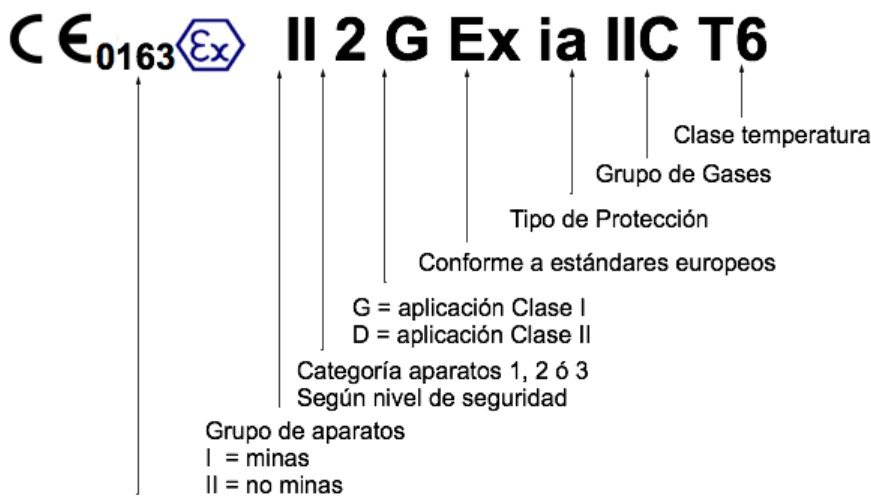
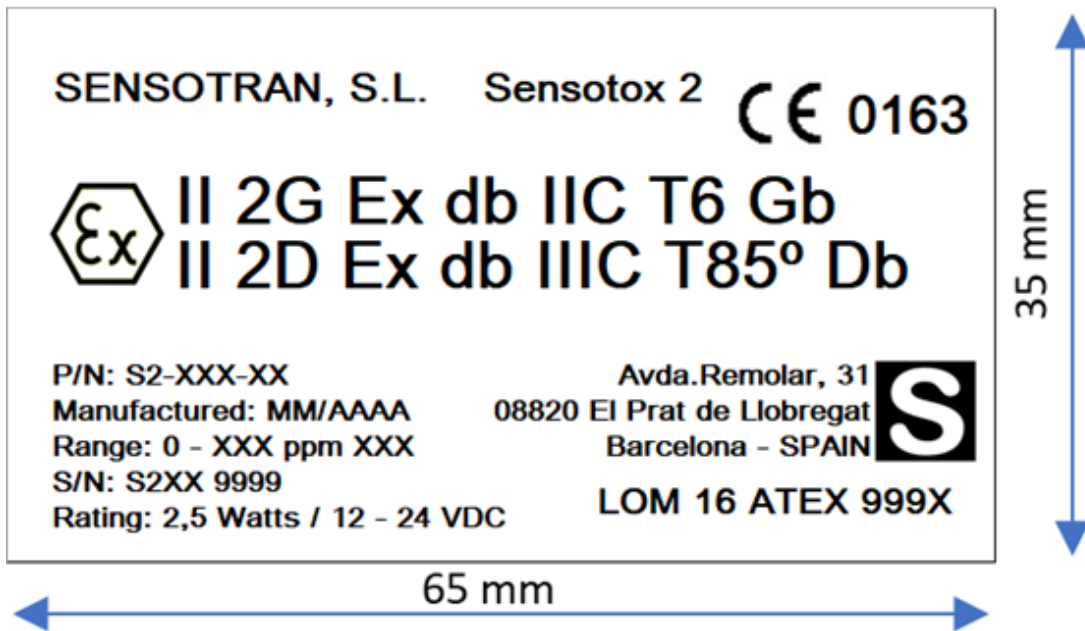

Identificación del ExNB que notifica la calidad de los Procesos productivos. Sólo para categorías 1 y 2.
 0163 = LOM 102 = PTB 0575 = demko

1.1 TECHNICAL SPECIFICATIONS

Sensotox2 EC specifications

Size	190 mm x 150 mm x 140 mm
Weight	1.6 kg
Sensor	Electrochemical
Calibration	2 points
IP	IP-68
Power supply	12-36 V dc, max. 50 mA at 24 V dc
Output	4 – 20 mA RS-485, at 4.8, 9.6 or 19.2 kB/s
Display	7 segments, 4 digits and 6 LEDs (unit with window)
User interface	Magnetic key, non-intrusive access for calibration and adjustment (unit with a window). Internal calibration buttons (blind unit)
Temperature	-40 a 60 °C
Humidity	0-95% RH (non-condensing)
Sensor Pressure	0.9 – 1.1 Atm
Box pressure	Max 50 bar / 10 s
Relay contacts*	30 V, 2 A normally open. One for alarm 1 and one for alarm 2.

*** Ask Sensotran for other possibilities.**

Sensotox2 IR specifications

Size	190 mm x 150 mm x 140 mm
Weight	1.6 kg
Sensor	Non-dispersive IR
Calibration	2 points
IP	IP-68
Power supply	12-36 V dc, max. 50 mA at 24 V dc
Output	4 – 20 mA RS-485, at 4.8, 9.6 or 19.2 kB/s
Display	7 segments, 4 digits and 6 LEDs (unit with window)
User interface	Magnetic key, non-intrusive access for calibration and adjustment (unit with a window). Internal calibration buttons (blind unit)
Temperature	-40 a 60 °C
Humidity	0-95% RH (non-condensing)
Sensor Pressure	0.9 – 1.1 Atm
Box pressure	Max 50 bar / 10 s
Sensor Pressure	0.9 – 1.1 Atm
Box pressure	Max 50 bar / 10 s
Relay contacts*	30 V, 2 A normally open. One for alarm 1 and one for alarm 2.

*** Ask Sensotran for other possibilities.**

Sensotox2 LEL specifications

Size	190 mm x 150 mm x 140 mm
Weight	1.6 kg
Sensor	Catalytic
Calibration	2 points
IP	IP-68
Power supply	12-36 V dc, max. 50 mA at 24 V dc
Output	4 – 20 mA RS-485, at 4.8, 9.6 or 19.2 kB/s
Display	7 segments, 4 digits and 6 LEDs (unit with window)
User interface	Magnetic key, non-intrusive access for calibration and adjustment (unit with a window). Internal calibration buttons (blind unit)
Temperature	-40 a 60 °C
Humidity	0-95% RH (non-condensing)
Sensor Pressure	0.9 – 1.1 Atm
Box pressure	Max 50 bar / 10 s
Relay contacts*	30 V, 2 A normally open. One for alarm 1 and one for alarm 2.

*** Ask Sensotran for other possibilities.**



The use in atmospheres containing silicones, chlorinated or halogenated compounds and from sulphur may damage the sensor

Sensotox2 PID Specifications

Size	190 mm x 150 mm x 140 mm
Weight	1.6 kg
Sensor	Photoionization
Calibration	2 points
IP	IP-68
Power supply	12-36 V dc, max. 50 mA at 24 V dc
Output	4 – 20 mA RS-485, at 4.8, 9.6 or 19.2 kB/s
Display	7 segments, 4 digits and 6 LEDs (unit with window)
User interface	Magnetic key, non-intrusive access for calibration and adjustment (unit with a window). Internal calibration buttons (blind unit)
Temperature	-40 a 60 °C
Humidity	0-95% RH (non-condensing)
Sensor Pressure	0.9 – 1.1 Atm
Box pressure	Max 50 bar / 10 s
Relay contacts*	30 V, 2 A normally open. One for alarm 1 and one for alarm 2.

*** Ask Sensotran for other possibilities.**

2. OPERATION

The calibration of all new instruments acquired from Sensotran should be checked by exposing the sensor to a known concentration of gas before putting the instrument into service. For maximum safety, accuracy should be checked by exposing the sensor to a known concentration of gas over a period of time.

Calibration must be checked daily during the initial period of use to ensure that there are no components in the atmosphere which might contaminate the sensor.

Check the calibration using a known concentration of gas before use. Recalibrate if the error is excessive.

Before shipment, Sensotox 2 instruments are calibrated and checked using Span gas. However, the user should check the operation before first use. Once the unit has been installed, leave it running for 24 hours and check it with gas.

2.1 PHYSICAL DESCRIPTION

The design of Sensotox 2 makes it easy to place and connect at a fixed location to monitor gas.

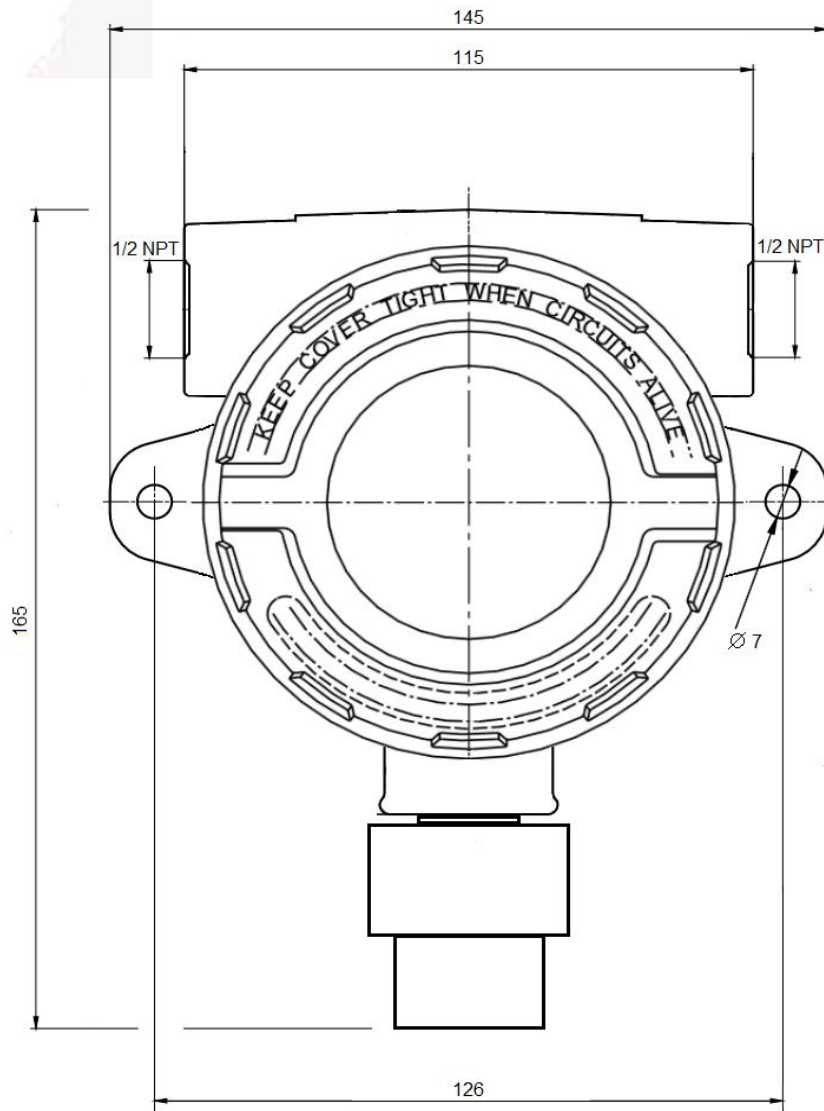

2.2 Installation

ATTENTION

- 1. At least 457 mm of armored cable must be used between group A and B zones.**
- 2. To prevent ignition in explosive atmospheres, the area must be free of flammable gases and the power supply to the detector must be disconnected before opening the cover.**
- 3. For European applications, the installation must meet the requirements of EN 60079-14.**

2.2.1 Installing

Make 2 holes in the mounting surface 126 mm apart.

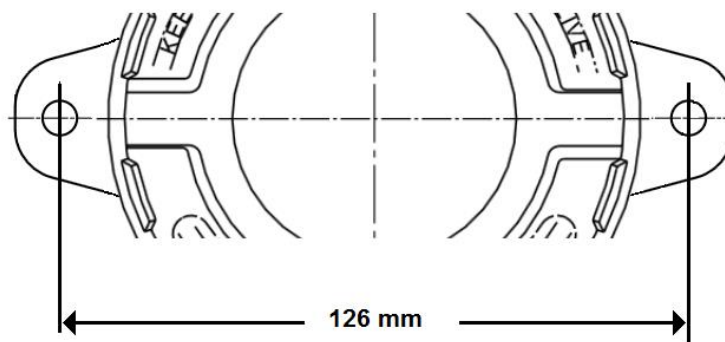

2.2.2 Uninstalling



Before dismantling, make sure that power is disconnected.

1. Unscrew the cover by rotating it anti-clockwise.
2. If the unit has a display, remove the four fixing screws and then the ribbon cable connector of the display.
3. Disconnect the power connectors and communication/relay connectors.
4. Disconnect the sensor connector.
5. Unscrew the four studs on the display.
6. Remove the main board.
7. Unscrew the sensor.

2.2.3 Wiring

1. Disconnect the two green connectors.

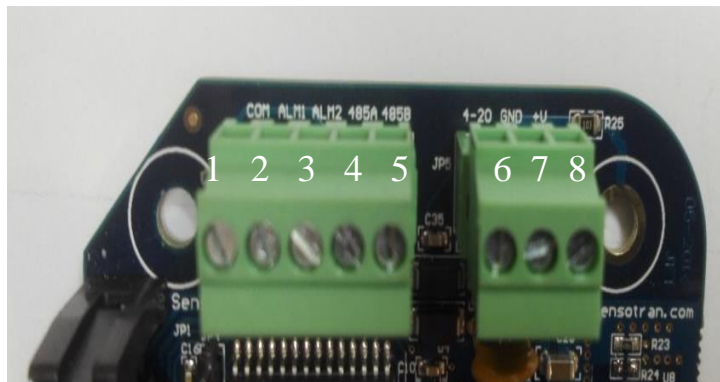

2. Connect the Sensotox 2 cables via the connection holes.
The pins correspond to the following table:

Terminal	Cable	Pin#
Block 1	Common alarm (*)	1
	Low Alarm (*)	2
	High Alarm / Fault (*)	3
	RS485A	4
	RS485B	5
Block 2	4-20 mA output	6
	Power supply -	7
	Power supply + (9 a 36 V)	8

(*) Only detectors with a window.

2.2.4 Installing the unit

1. Fit the connectors into their respective locations. Save an extra length of cable to allow mounting on the wall.
2. Screw the sensor into the box and place connector
3. On units with a window, fit the 16-contact flat cable and separators.
4. On units with a window, fix the display and relay board using four 4 mm screws.
5. Screw the cover on

2.2.5 Earthing instructions

External earth connection

Crimp 4 mm² cable into a 4 mm connector.

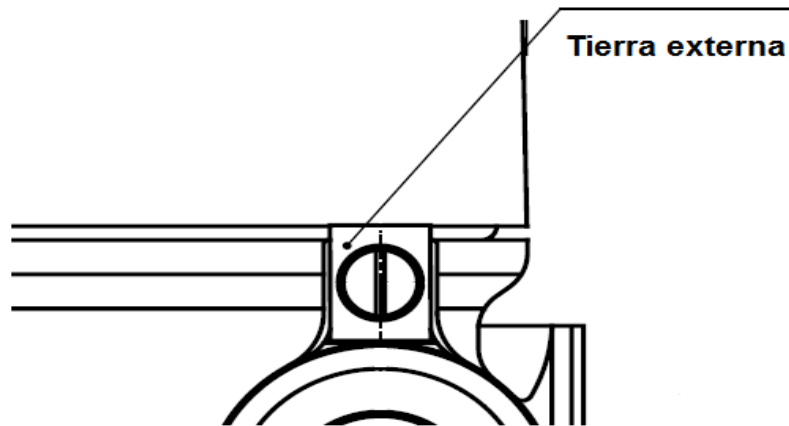

Internal earth

Use the same terminal as for the external earth connection.

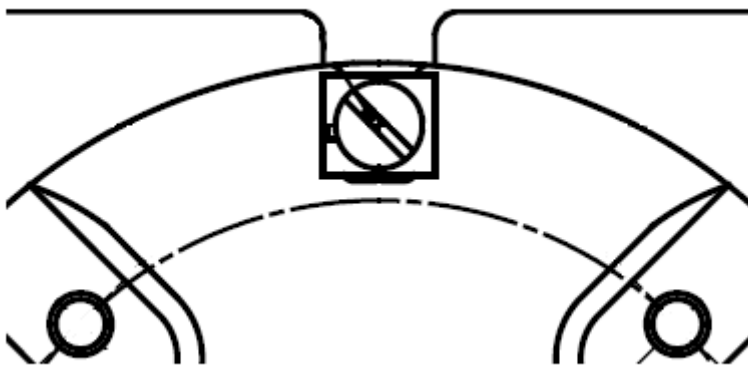

2.3 Display and User Interface

2.3.1 User interface

All Sensotox 2 devices with a window are equipped with four status LEDs, a four-digit LCD display and three magnetic keys [+], [MODE] and [-].



The blind Sensotox 2 have a small seven segments display with three mechanical keys: [+], [MODE] and [-] on the main board. The data to be displayed will have up to 4 digits, displayed sequentially. The first digit is distinguished because the off time is longer than the rest. For example, for to show data 1234 would be:

1 → 2 → 3 → 4

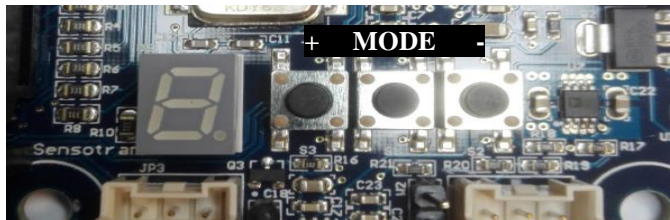

2.3.2 Magnetic key

The Sensotox 2 with window has no external keys, but uses the magnet to activate keys inside the unit. Place the magnet over the key to activate the desired button.

2.3.3 Using the magnet

Briefly touch the magnet onto the MODE circle or the [+] and [-] triangles.

Important! Do not drag the magnet, since two functions might be activated.

2.3.4 Starting up the unit

Both the window detector and the blind one require a start-up time that depends on the built-in sensor.

"InIt" is displayed on the detector with a window, alternating with a countdown. When the count reaches zero, the detector is operative.

In both the window detector and the blind one, the analogue output current is 2 mA during the start-up time. When the start-up time has elapsed, and provided there is no fault condition, the 4/20 mA analogue output current will be proportional to the sensor reading.

2.3.5 Display readout

In the detectors with window, once the detector goes into read mode, it starts an automatic check for possible faults and alarm conditions. If there is no fault or alarm condition, the green "Ok" LED is activated and the gas concentration is shown.

2.3.6 Alarm contacts

The alarm contacts or alarm relays can be used to activate acoustic or luminous alarms. External alarms have normally open contacts which close when there is an alarm.

	External alarm	LED	LCD	Analogue output
Exceeds the low alarm threshold	Alarm ALM1	Low	Reading	Based on reading
Exceeds the high alarm threshold	Alarm ALM1	High	Reading	Based on reading
Out of range	Alarm ALM2	High	8888	22 mA
Calibration fault	Alarm ALM2	Fault	E003 flashing	2 mA
Sensor drift	Alarm ALM2	Fault	E004 flashing	2 mA
ADC saturated	Alarm ALM2	Fault	E005 flashing	2 mA

2.4 Calibration



ATTENTION

The calibration of all unit purchased from Sensotran should be tested by exposing the sensor to a known concentration of gas before putting the instrument into service. For maximum safety, the accuracy of Sensotox 2 should be checked by exposing the sensor to a known concentration of gas over a period of time

Sensotox 2 units are calibrated using a two-point calibration process. First, use the "Zero calibration", then the "SPAN calibration" exposing the sensor to a reference gas concentration to establish the second calibration point.

Note: "Zero calibration" must be carried out before "Span Calibration".

The calibration requires a zero cylinder, a Span cylinder and a calibration adapter.



Sensotox 2 connected to a calibration gas cylinder with an adapter.

2.4.1 Calibration

I - Zero calibration

1. Ensure that there are no flammable gases or gases that might interfere with the sensor reading in the area where the detector is located. Suspected that the atmosphere is not clean, use a zero gas such as Nitrogen 5.0
2. To accede to Calibration Menu, Press [MODE] from the actual reading screen. A "ZERO" message appears on the screen.

Tip: To pass to Span Calibration, press [MODE].

To return to actual reading press [-].

3. In atmosphere with pollutants, connect the calibration ZERO cylinder to the sensor head of the Sensotox 2 using the calibration adapter and apply the gas flow.
4. Press [+] to start calibration.
 - On display units:

The Zero LED will be lit and "2ErO" message will be displayed alternatively with a countdown.
 - On blind units:

The internal display shows "2" blinking.

Tip: Before countdown will finish, you can cancel calibration by pressing any key.
5. When calibration is completed, calibration data will be saved.

Note: The machine returns to reading the display after 60 seconds of inactivity.

When Zero Calibration will be finished, instrument will advance to Span Calibration.

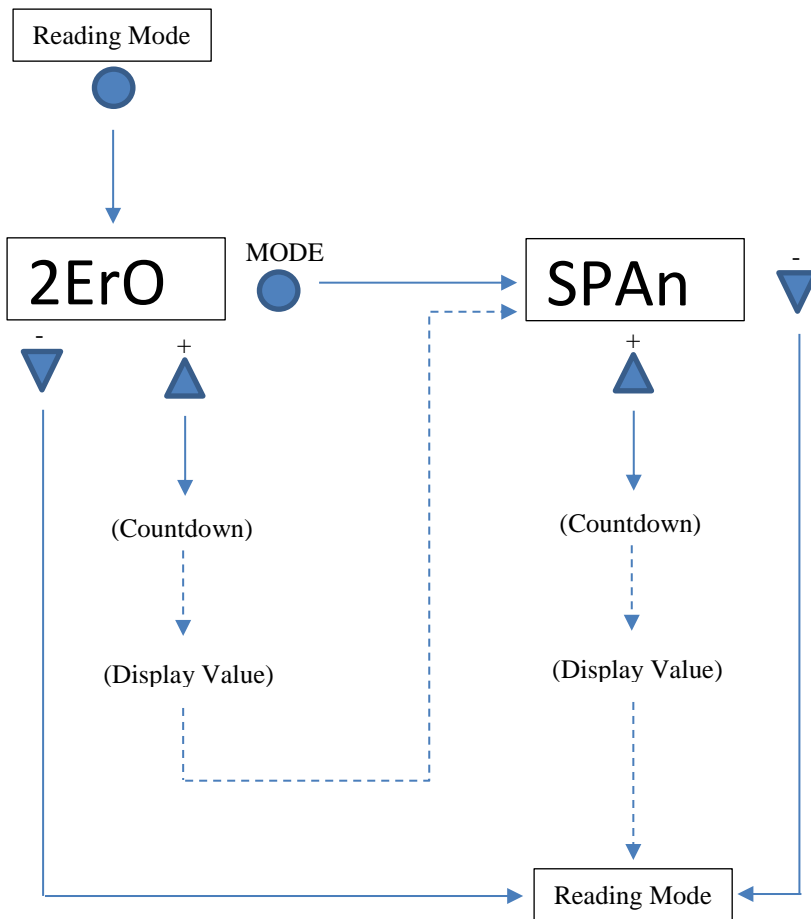

II - Span calibration

1. Connect the SPAN calibration cylinder to the sensor Sensotox 2 head using the calibration adapter and applying a flow of gas.

Tip: To accede the Span Calibration from reading display, press [MODE]. When "2ERO" appears, press [MODE] again to go to "SpAn".

Tip: To exit the calibration menu, press [-] to return the normal reading.

Note: It is not necessary to exit from the calibration menu manually. After 60 seconds of inactivity, the Sensotox 2 automatically returns to the normal reading.

2. Press [+] to start calibration.

- On display units:

The Span LED will be lit and "5PAn" message will be displayed alternatively with a countdown.

- On blind units:

The internal display shows "5" blinking.

Note: Wait for the countdown in order to obtain a full calibration.

Tip: Before countdown will finish, you can cancel calibration by pressing any key.

3. Once the calibration is completed, if the sensor does not have sensitivity enough for being calibrated, "FAIL" and "5PAn" messages will be displayed alternatively.

Note: Can be necessary replace the sensor if the Span calibration fails.

4. If the sensor sensitivity is acceptable, the Span data will be calculated and saved.
5. Once the calibration procedure is complete, after a few seconds the Sensotox 2 will return to the normal reading.
6. Turn off the Span calibration gas cylinder and remove it.

On the event of a failed calibration, call Sensotran Service at +34 93 478 58 42 or follow the Sensor Replacement Instructions

2.5 Sensor replacement

1. Declassify the area.
2. Loosen the head clamping screw.
3. Unscrew the head.
4. Replace the sensor.
5. Proceed to assemble the head in the reverse order of disassembly.

2.6 Advanced Menu

Sensotox 2 Advanced Menu let you modify several configuration parameters. To enter into Advanced Menu, press the sequence [+], [-] and [MODE]. Display will show then "CALu".

- Pressing [MODE] will move to the next function.
- Pressing [+] will enter into the setting and show the actual value.
- Pressing [-] will leave the Advanced Menu.

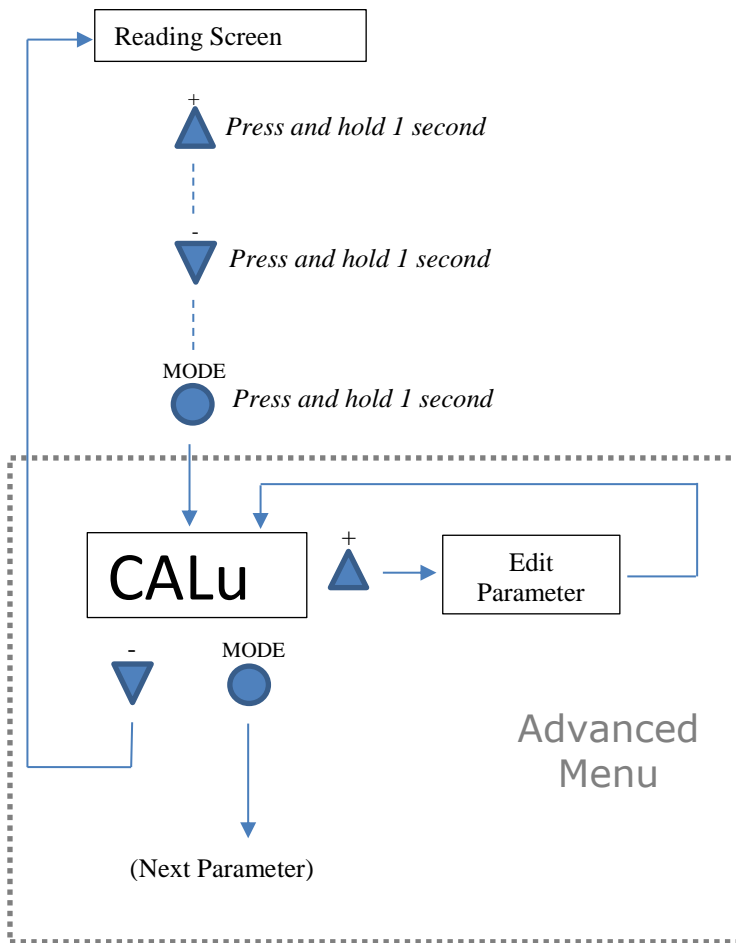

After 60 seconds without activity, detector returns to actual reading screen.

Advanced Menu

Display	Setting
CALu	Span Calibration value
FC	Correction Factor (for LEL & VOC only)
LO	Low Alarm
HI	Hi Alarm
Id	Instrument ID
bAUd	Transmission Speed (19200, 9600 or 4800)
Lite	Backlight
Aout	Analogue output (4 / 20 mA)

- To modify a setting, press [MODE] until desired value appears.
- Press [+] to enter into the setting.
- Press [+] to increase/change the value.
- Press [-] to decrease/change the value.
- When finished, press [MODE].

If the setting has been modified, new value will blink.

- Press [-] or [MODE] to dismiss modifications and go to next setting.
- Press [+] to save changes.

“SAuE” will be displayed to confirm changes have been stored.

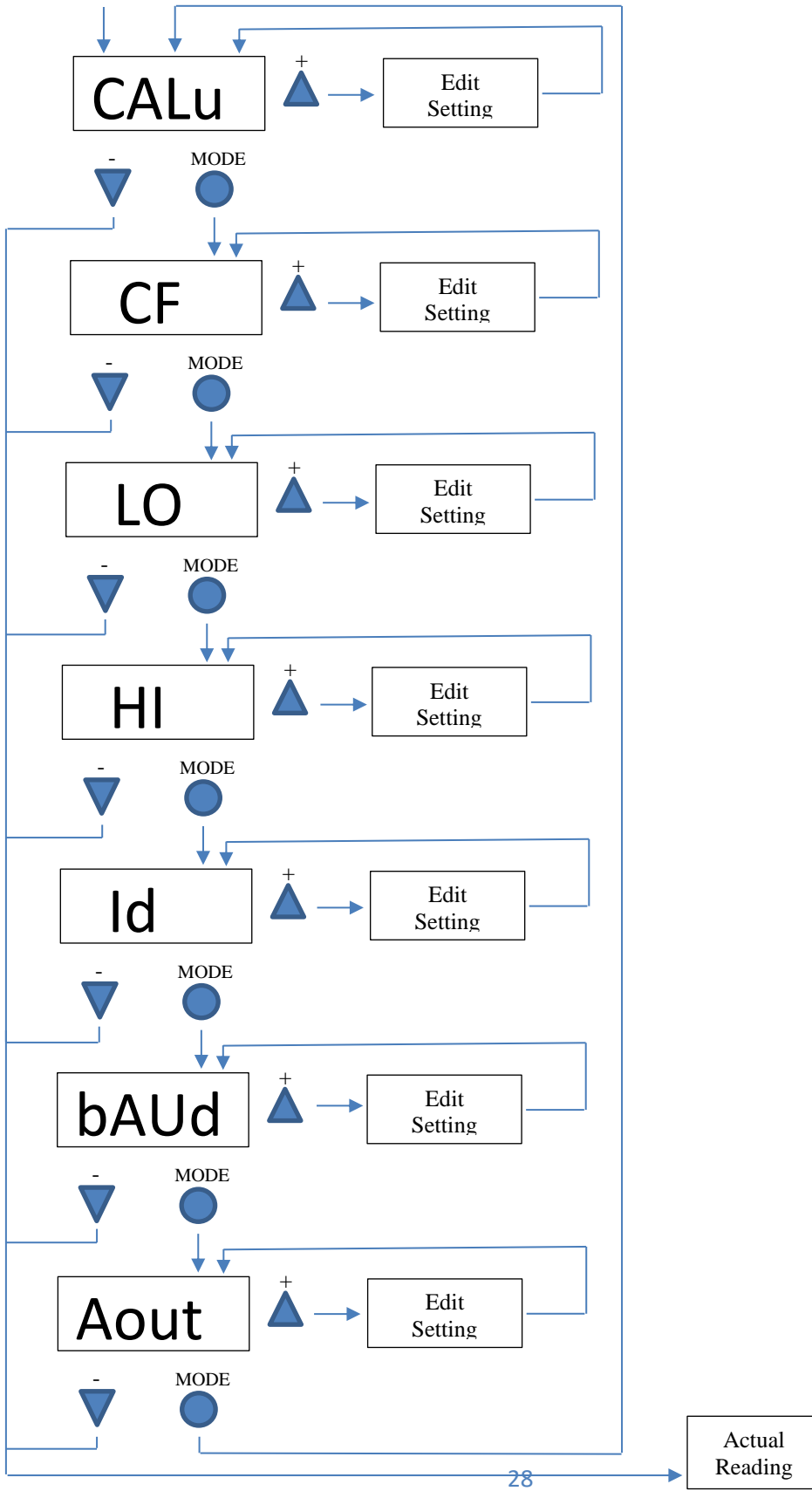

How to edit and modify Settings.

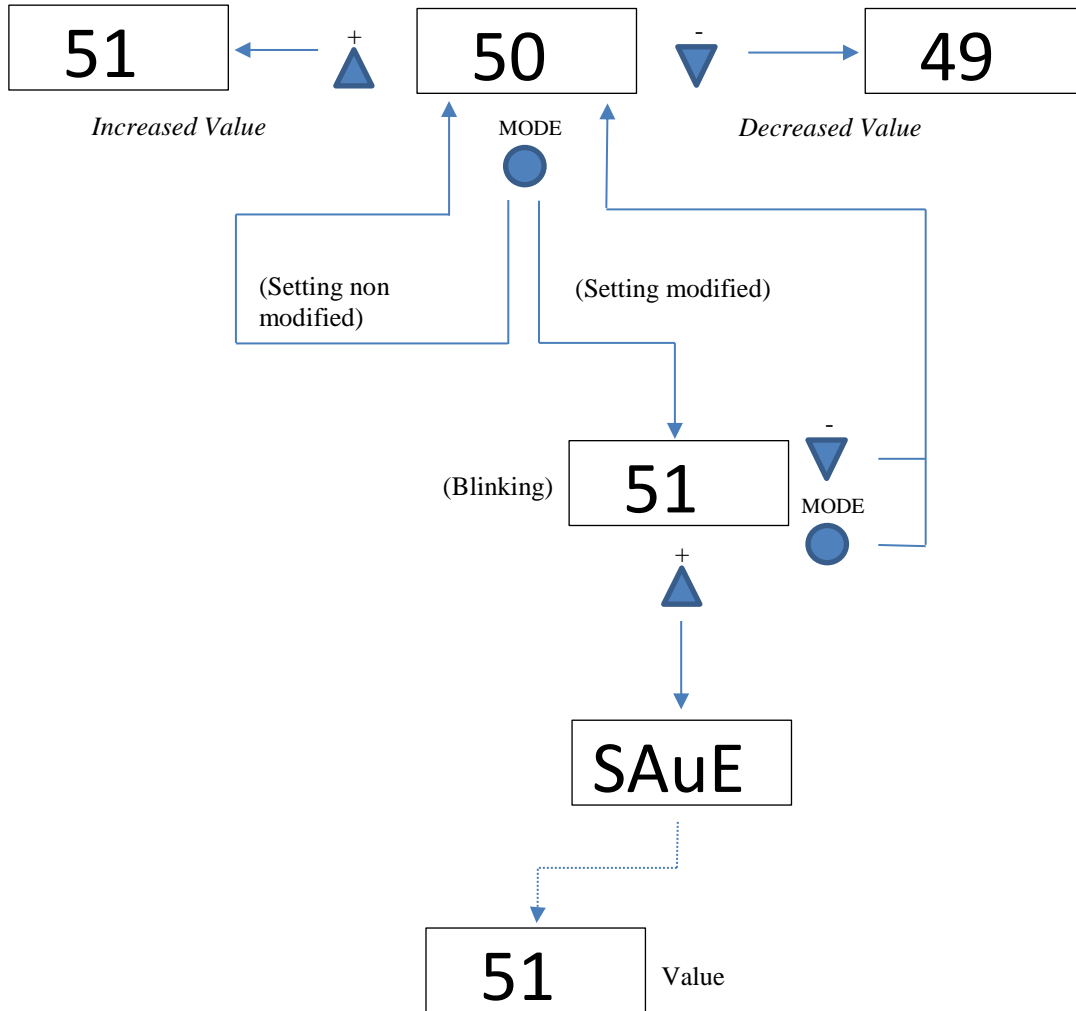

4-20 mA Analogue Output adjustment.

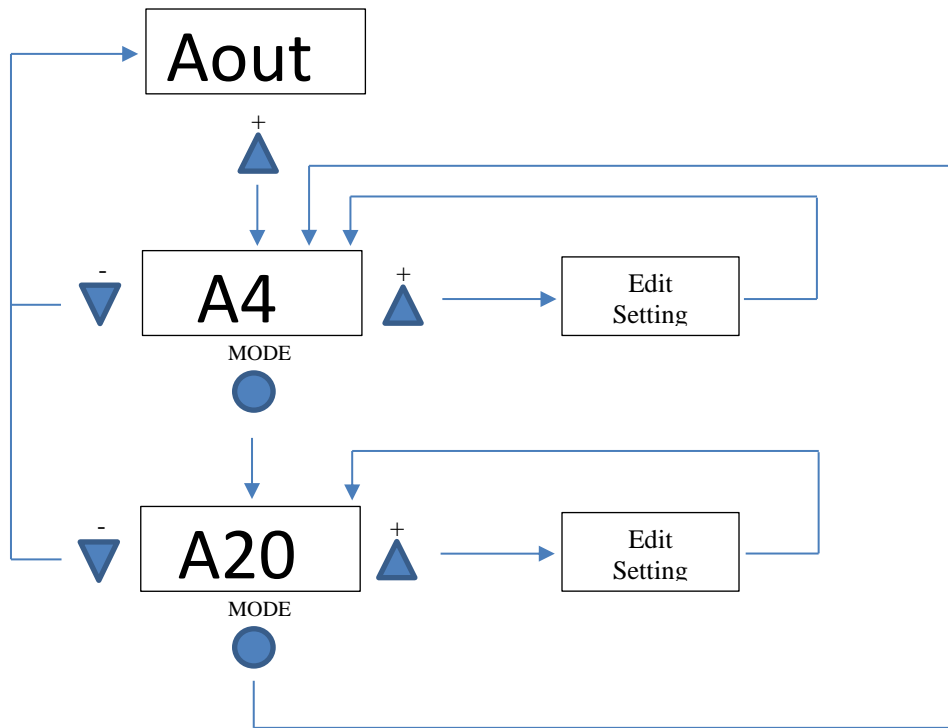

3. Troubleshooting

Error	Description and solution
E003	Description: Calibration error Solution: Make sure there is gas flow circulation and repeat calibration. If still fails, replace the sensor.
E004	Description: Zero Drift Solution: Make sure sensor is in a clean ambient or alternatively, use Nitrogen to do zero calibration.
E005	Description: Sensor Over range Solution: Call an Authorized Service Centre.
E006	Description: Wiring Error Solution: Verify wiring
E007	Description: EEPROM Error Solution: Replace main board. Call an Authorized Service Centre.

4. MODBUS/RS-485

Retrieving gas concentration data from Sensotox 2 through RS-485.

The Sensotox 2 communicates by means of MODBUS RTU. All monitors provide 4-byte register value. Note: Gas concentration is the only value that can be retrieved.

As example 34 hex = 52 decimal.

1. Communication Setting

Transmission MODE:RTU

Controller: PC or GasVisor Controller.

Baud Rate: 4800, 9600, 19200 bps.

Client ID: 1 to 32

2. Message Frame/Communication Procedure

Sensotox 2 only support function code 0x03 (read holding registers), which only supports the "Get Reading Value" from the detector.

Requesting Message:

Device Address	Function Code	Register Address High Byte	Register Address Low Byte	Quantity of Registers High Byte	Quantity of Registers Low Byte	CRC Low Byte	CRC High Byte
Client ID	03	00	02	00	02	CRC	CRC

Answering Message:

Device Address	Function Code	Byte Count	Register Value				CRC Low Byte	CRC High Byte
Client ID	03	04	Reading byte 4	Reading byte 3	Reading byte 2	Reading byte 1	CRC	CRC

Note: Detector data length is 4 bytes.

Example:

Request: 01 03 00 02 00 02 CRC CRC

Answer: 01 03 04 **00 00 00 3A** 7A 20

Note: The maximum distance should be less than 1 Km when using a 1.5 mm² cable.

sensotran, s.l. Avda. Remolar, 31 08820 El Prat de Llobregat Barcelona (Spain) Tel. +34 93 478 5842 www.sensotran.com	DoC En Rev. 2	Date: 10/04/2018 Copy Authorised by: Marc Delgado
---	--------------------------	---

EC DECLARATION OF CONFORMITY	
SENSOTOX 2 (SX-XXX-XX)	Declaration number: 20017001
SENSOTOX BE (SB-XXX-XX)	
Description: Fixed gas detector Use: Toxic, flammable, oxygen, CO2 & VOC monitoring on hazardous area.	
We hereby declare in our sole responsibility that the products above described, are in conformity with the following standard(s) or normative documents:	
ATEX 2014/34/UE	
Notified Body:	Laboratorio Oficial Madariaga (LOM) Eric Kandel, 1 – 28906 Getafe - Spain
Num. Notified Body:	0163
CE Certificate Number:	LOM17ATEX1037X
According to:	
EN 60079-0:2013/A11	Explosive atmospheres - General requirements
EN 60079-1:2014	Explosive atmospheres. Equipment protection by flameproof enclosures "d"
EN 60079-31:2014	Explosive atmospheres. Equipment dust ignition protection by enclosure "t"
Type approval:	 II 2G Ex db IIC T6 Gb II 2D Ex tb IIIC T85°C Db
Production Quality Control	
QC Certificate number:	XXXX XX ATEX X XXX
According to:	
EN ISO/IEC 80079-34:2012	Application of quality systems for equipment manufacture
Electromagnetic Compatibility (EMC) Directive 2014/30UE	
According to:	
EN 50270:2015	Electrical apparatus for the detection and measurement of combustible gases, toxic gases or oxygen.
	
Marc Delgado – Technical Manager El Prat de Llobregat April 10 th , 2018	

sensotran, s.l.

Av. Remolar 31

BARCELONA - SPAIN

Phone: +34 93 478 5842

www.sensotran.com

e-mail: sensotran@sensotran.com