



MP30-EX

# Analytical Diaphragm Pump Series MP®

Version MP30, MP30-EX

## Special Features

- Corrosion resistant
- 100% lubricant free
- Gas tight
- Maintenance free
- Long service life
- Explosion proof version according to ATEX for zone 1
- Small dimensions, high performance

## Application

This diaphragm pump MP30.. is suitable for corrosive gases. It is constructed especially for applications in gasanalysis technique.

## Description

The pump MP30.. has a PVDF-head. All sample contacting parts are made of PVDF, PTFE and FFKM. The pump works absolutely lubricant free, so gases remain analytically unchanged. Due to a special diaphragm and valve system, the pump operates maintenance-free.

The MP30... is available in 230V or 115V and in execution according to ATEX  II2G for applications in hazardous areas as well.

The standard MP30.. is designed for normal applications at a maximum gas flow of 7l/min.

## Dimensions

### Pump MP30

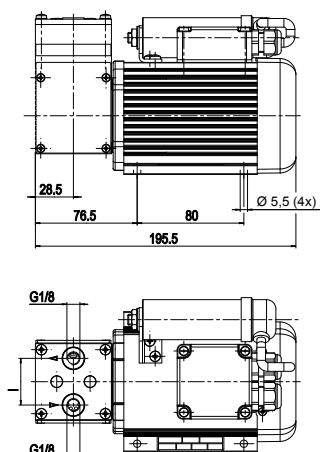

### Pump MP30-EX with an ex-motor

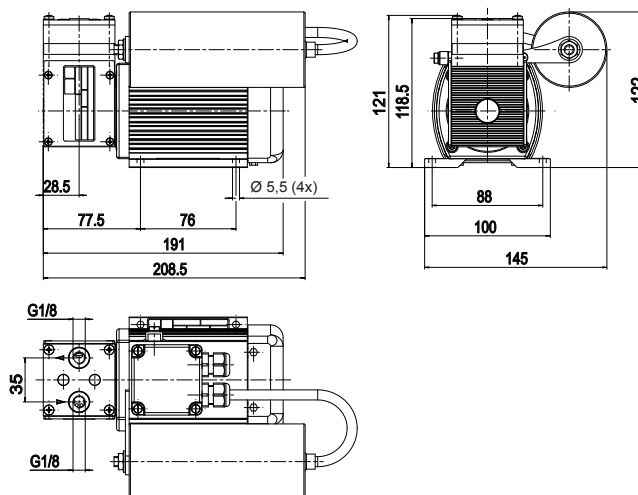

Dimensions in mm

## Performance characteristics MP30..

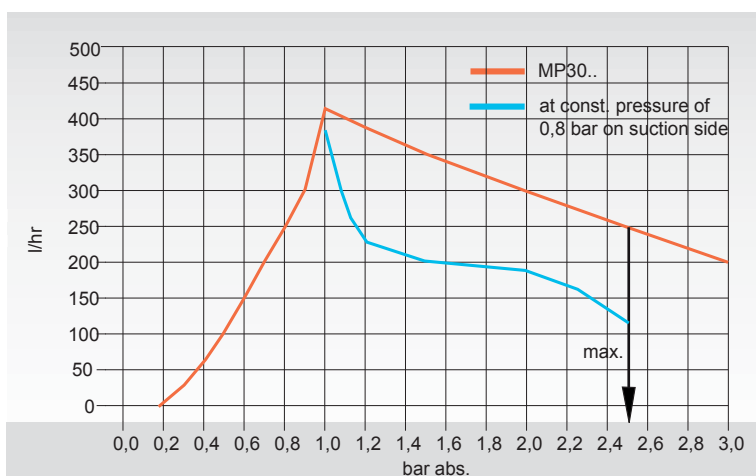

Working pressure for MP30.. is max. 2,5bar abs.

## Technical Data

Diaphragm pump	MP30 230V/50Hz	MP30 115V/60Hz	MP30-EX 230V/50Hz	MP30-EX 115V/60Hz
Part number	02 P 1500	02 P 1500a	02 P 1550	02 P 1550a
Degree of protection	IP 54 EN 60529		II2G EEx de, q IIB T4 IP 54 EN 60529	
Power consumption	70W		65W	60W
Current consumption	0,45A	0,7A	0,3A	0,45A
Capacity max.	7,0 l/min without pressure 0,9 / 2,0 bar abs. on suction / pressure side: 5 l/min			
Operating pressure	0,2 to 2,5 bar abs.			
Sample temperature	+5 to +40 °C			
Ambient temperature	+5 to +40 °C			
Storage temperature	-15 to +60 °C			
Gas connections	G1/8" i DIN ISO 228/1			
Material of sample contacting parts	pump head: PVDF, SS316Ti, diaphragm: PTFE, valves: FFM			
Operation mode	100% continuous duty, start of the pump only without pressure			
Weight	3,1 Kg		3,3 Kg	