



**testa in ottone**  
brass head



**bielle in alluminio**  
connecting-rods in aluminium



**motore idraulico**  
hydraulic drive

CM 228606  
sp\_30060\_HYD\_XM.pdf  
MI 90008+91422

DI 1788515

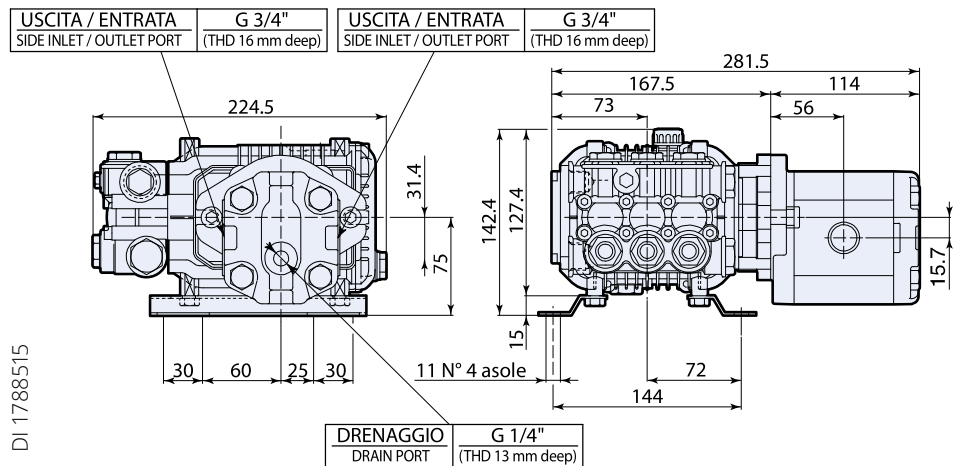

## HYD - XM

MOD	COD	POMPA A PISTONI • HP PISTON PUMP						MOTORE IDRAULICO • HYDRAULIC MOTOR						KG NET
		MAX	MAX	RPM	⚡	MAX	MAX	RPM	⚡	MAX	MAX	RPM	⚡	
		l/min	gpm	bar	psi	N° giri/1'	hp	Type	Cod	cm <sup>3</sup>	bar	l/min	N° giri/1'	kg
<b>HYD-XM</b>														
HYD-XM 15.15	<b>21660</b>	15	3,96	150	2200	1450	5,5	SNM2NN/019 BN06GAM1F5F5N	4769	19,2	105	29	1450	17

### Caratteristiche Generali

Kit pompa a pistoni per il lavaggio dell'irroratrice, a fine trattamento, prima della messa in strada. Mod. XM 15.15, valvola di regolazione Mini Matic 4/B con ritorno automatico della pompa a 0 bar alla chiusura, by-pass, con iniettore detergente regolabile, manometro Ø40mm, 16m tubo AP 5/16" DN8 200bar 100°C, pistola AR 334 con sicura, lancia con testina regolabile Reg Spray 5. Completo di motore idraulico modello Sauer Danfoss.

### General Features

*Piston pump kit for washing the sprayer, at the end of treatment, before use. Model XM 15.15, Mini Matic 4/B regulation valve with automatic return of pump to 0 bar upon closure, by-pass with adjustable detergent injector, Ø40mm pressure gauge, 16m tube AP 5/16" DN8 200bar 100°C, AR 334 spray gun with safety catch, lance with Reg Spray 5 adjustable head. Complete with Sauer Danfoss model hydraulic motor.*