

# PTO Slip Clutch and Overrun Coupler 150HP #225

Allows PTO driven implements to freewheel with adjustable safety protection under load.  
Prevents single clutch tractors from being driven forward by PTO over-run.  
Integral heavy duty adjustable disc type safety clutch protects PTO drive line.

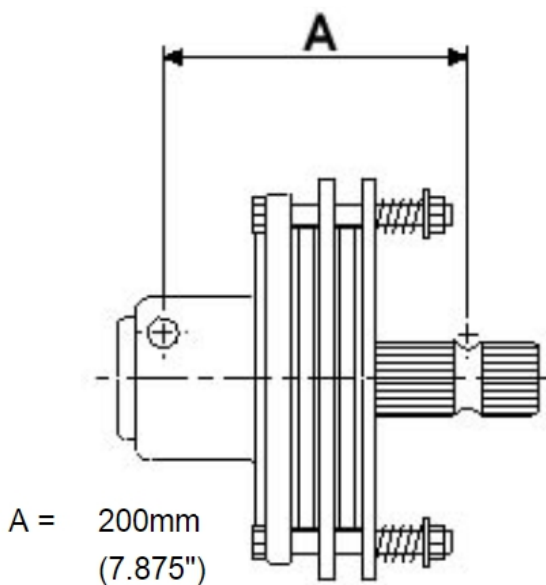

**For rear mounted PTO applications.**  
**1 3/4" 6 Spline Female - 1 3/8" 6 Spline Male.**  
**150HP capacity 4 plate clutch.**  
**Clutch plate Ø: 200mm (8") Ø.**



### REMEMBER THIS!

To adjust these BARE-Co PTO clutches:

Basic Spring Length 31.75mm (1 1/4")

Adjust to slip on overload.

At 6 Months, back off to polish discs.

<i>Tighten Shaft Clamping Bolts as Below.</i>	
<i>Repeat after 8 Hours + every 40 hours.</i>	
Pair of 1/2" dia Clamp Bolts	<b>75 ft lbs</b>
Pair of 5/8" dia Clamp Bolts	<b>150 ft lbs</b>
Single Cotter Clamp Bolt	<b>100 ft lbs</b>

**Note: LOOSE BOLTS = STRIPPED SPLINES.**

**2 spare plates**



2638



2639



+44 1743 850761  
gwaza.co.uk  
sales@gwaza.co.uk