

ELENCO PEZZI DI RICAMBIO
 LISTE PIECES DETACHEES
 SPARE PARTS LIST
 ERSATZTEILLISTE
 PIEZAS DE REPUESTO

MASTERMIG 500

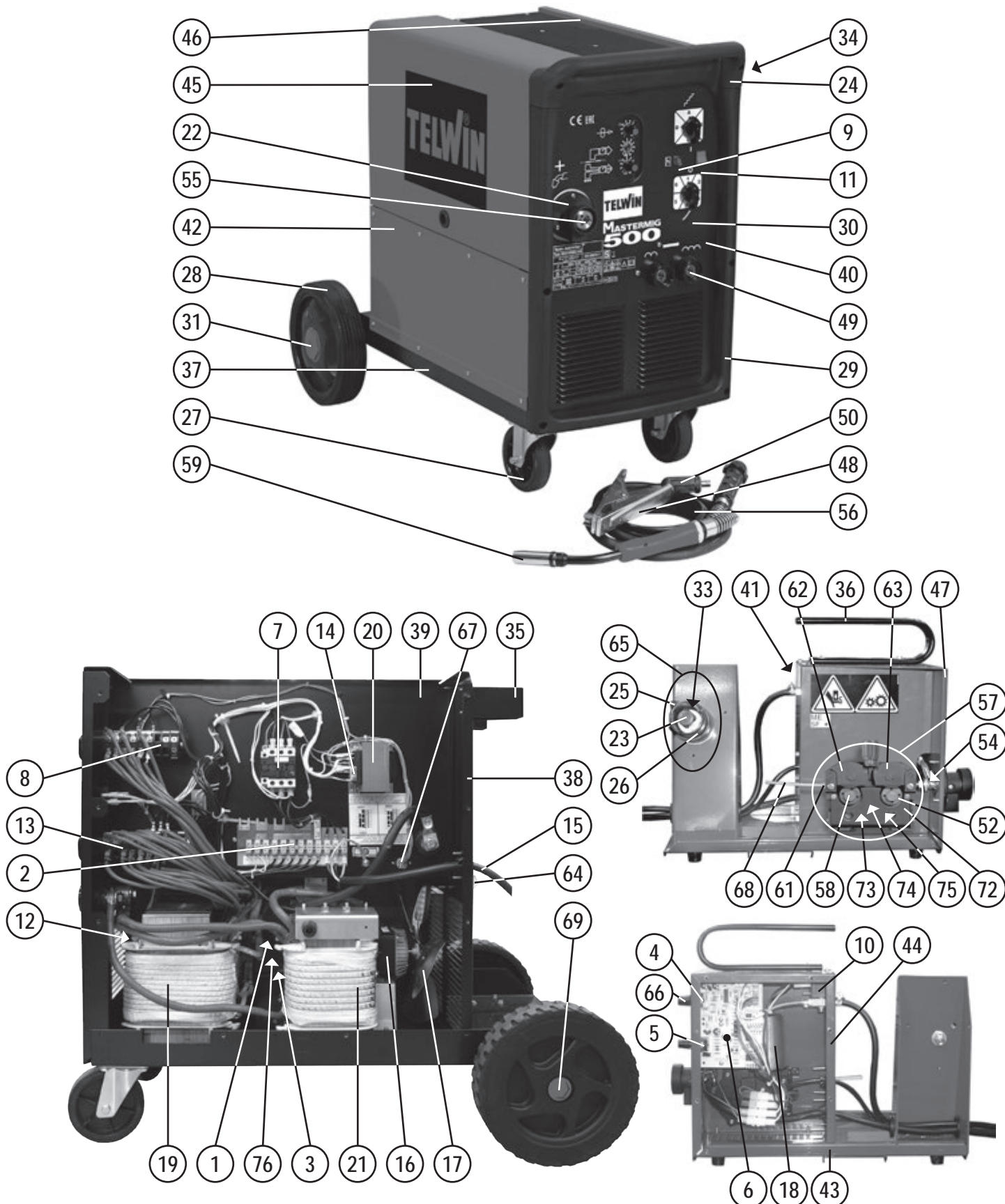

Esplodo macchina, Dessin appareil, Machine drawing, Explosions Zeichnung des Geräts, Diseño seccionado maquina.



REF.	ELENCO PEZZI DI RICAMBIO PIECES DETACHEES SPARE PARTS LIST ERSATZTEILLISTE PIEZAS DE REPUESTO	CODICE CODE KODE
1	Raddrizzatore trifase Redresseur threephasée Three-phase rectifier Dreiphasiger gleichrichter Rectificador trifásico	121391
2	Basetta cambio tensione Platine pour change tension Voltage changing card Wechselspannungskarte Base cambio tension	112163
3	Protezione raddrizzatore Protection redresseur Rectifier protection Gleichrichterschutz Protector rectificador	112182
4	Potenzimetro Potentiometre Potentiometer Potentiometer Potenciometro	116411
5	Potenzimetro Potentiometre Potentiometer Potentiometer Potenciometro	113574
6	Kit scheda controllo timer Kit carte controle timer Timer control pcb kit Timer steuerungskarte kit Kit tarjeta control timer	980714
7	Contattore Contacteur Contactor Kontaktgeber Contactor	121214
8	Commutatore Commutateur Switch Schalter Switch	121399
9	Lampada gialla Temoin lumineux jaune Yellow pilot lamp Gelbe kontrollampe Piloto amarillo	122594
10	Elettrovalvola Electrovanne Electrovalve Elektroventil Electrovalvula	121801
11	Interruttore Interrupteur Switch Schalter Interruptor	122725
12	Kit termostato Kit thermostat Kit thermostat Thermostat kit Kit termostato	981968
13	Commutatore Commutateur Switch Schalter Switch	121400
14	Fusibile Fusible Fuse Sicherung Fusible	122879
15	Cavo alim. 4g6 3 m Cable alim. 4g6 3 m Mains cable 4g6 3 m Netzkabel 4g6 3 m Cable alim. 4g6 3 m	132202
16	Motore Moteur Motor Motor Motor	152083
17	Ventola Helice Fan blade Fluegelrad Aventador	152113
18	Motoriduttore 24v dc Motoriducteur 24v dc Motoreducer 24v dc Motoriduktor 24v dc Motoriductor 24v dc	153039
19	Trasformatore Transformateur Transformer Trafo Transformateur	169640
20	Trasformatore ausiliario Transformateur auxiliaire Auxiliary transformer Hilfsrafo Transformador auxiliar	164991
21	Reattanza Reactance Reactance Drossel Induccion	169512

REF.	ELENCO PEZZI DI RICAMBIO PIECES DETACHEES SPARE PARTS LIST ERSATZTEILLISTE PIEZAS DE REPUESTO	CODICE CODE KODE
22	Protezione attacco torcia Support isolant torche Torch connection protection Brennersisolierlager Sosten isolator antorcha Volantino per aspo Volant pour support bobine Reel handwheel Wicklerhandrad Volant por aspa	312105
23	Volantino per aspo Volant pour support bobine Reel handwheel Wicklerhandrad Volant por aspa	312137
24	Kit manico Kit poignee Handle kit Handgriff kit Kit manija	980082
25	Aspo Support bobine Reel Wickler Aspa	322081
26	Distanziale Entretoise Spacer Abstandstueck Anillo por distanciar	322180
27	Ruota girevole Roue tournante Swivel wheel Bewegliches rad Rueda giratoria	322194
28	Ruota Roue Wheel Rad Rueda	321389
29	Cornice Cadre Frame Rahmen Marco	322736
30	Assieme manopola per commutatore Set poigne pour commutateur Switch knob set Umschaltergriff set Set manija para conmutador	323101
31	Asse ruote Axe roues Wheels axle Radachse Eje ruedas	422020
32	Adattatore bombola argon it Adaptateur bouteille argon it Argon gas bottle it adaptor Argongasflasche it passtück Adaptador bombona argon it	432036
33	Molla per aspo Ressort pour support bobine Reel spring Wicklerfeder Muelle por aspa	452057
34	Gancio appendi torcia Accrocheur torche Torch hook Haken fuer brenner Gancho fijacion antorcha	644444
35	Portabombola Porte-bouteille Bottle holder Flaschenhalter Apoyo bombona	644447
36	Manico trainafilo Poignee por devidoir Wire feed handle Drahtvorschubhandgriff Manija por arrastre hilo	644449
37	Fondo Chassis Bottom Bodenteil Fondo	645102
38	Retro Partie arriere Back panel Rueckseite Trasera	645103
39	Diaphragma Diaphragme Diaphragm Diaphragma Diafragma	645105
40	Frontale Partie frontal Front panel Geraetefront Frontal	642051
41	Fianco Partie lateral Side panel Seitenblech Flanco	645236
42	Fianco Partie lateral Side panel Seitenblech Flanco	651059

REF.	ELENCO PEZZI DI RICAMBIO PIECES DETACHEES SPARE PARTS LIST ERSATZTEILLISTE PIEZAS DE REPUESTO	CODICE CODE KODE
43	Fondo Chassis Bottom Bodenteil Fondo	645235
44	Retro Partie arriere Back panel Rueckseite Trasera	645419
45	Kit sportello Kit guichet Door kit Tuer kit Kit portezuela	980918
46	Kit mantello Kit capot Cover kit Deckelkit Kit panel de cobertura	980866
47	Frontale Partie frontal Front panel Geraetefront Frontal	649829
48	Toledo 400 pinza di massa 400a Toledo 400 pince de masse 400a Toledo 400 work clamp 400a Toledo 400 masseklemme 400a Toledo 400 pinza de masa 400a	712032
49	Presadina dx 50 Prise dix dx 50 Dinse socket dx 50 Dinse steckdose dx 50 Enchufe dinse dx 50	712036
50	Spina dinse dx 50 Fiche dinse dx 50 Dinse plug dx 50 Dinse stecker dx 50 Enchufe dinse dx 50	712040
51	Rullino traino 4r 0,6fe-0,8fe Galet 4r 0,6fe-0,8fe Feed roll 4r 0,6fe-0,8fe Vorschubrolle 4r 0,6fe-0,8fe Roldana 4r 0,6fe-0,8fe	742576
52	Rullino d. 0,8-1 Mm fe Galet d. 0,8-1 Mm fe Feed roll d. 0,8-1 Mm fe Vorschubrolle d. 0,8-1 Mm fe Roldana d. 0,8-1 Mm fe	722227
53	Riduttore pressione 2 manometri Reducteur pression 2 manometres Gas regulator 2 manometers Druckminderer 2 manometer Reductor presion 2 manometros	722346
54	Tubo capillare ø 2x5 Tuyau capillaire ø 2x5 Wire conduit ø 2x5 Kapillarrohr ø 2x5 Tubo capilar ø 2x5	742365
55	Attacco torcia Attelage torche Torch connection Brenneranschluss Enganche soplete	723229
56	Pinza di massa + cavo 50mmq 3m dx50 Pince de masse + cable 50mmq 3m dx50 Work clamp + cable 50mmq 3m dx50 Massezange + kabel 50mmq 3m dx50 Pinca de masa + cable 50mmq 3m dx50	804125
57	Traino 4 rulli Devidoir 4 rouleaux 4 Roll wirefeeder 4 Räder drahtvorschub Alimentador de hilo 4 rodillos	981928
58	Vite bloccarullino Vis ferme galet Rollerfixing screw Rollerhalterschraube Tornillo bloque roldana	742397
59	Mi36 torcia mig 3 m Mi36 torche mig 3 m Mi36 mig torch 3 m Mi36 mig brenner 3 m Mi36 antorcha mig 3 m	742186
60	Rullino d. 0,8-1 Mm al Gmm alet d. 0,8-1 Mm al Feed roll d. 0,8-1 Mm mm al Vorschubrolle d. 0,8-1 Mm al Roldana d. 0,8-1 Mm al	742304
61	Entrata guida filo Entree guide fil Wire guide inlet Drahtfuehrungsseeleingang Entrada vaina guialdera alambre	742064
62	Ancora controrullino sinistra Ancre contre-galet gauche Left anchor for pressure roller Linker anker für gegenrolle Ancora izquierda para contra roldana	981929
63	Ancora controrullino destra Ancre contre-galet droit Right anchor for pressure roller Rechter anker für gegenrolle Ancora derecha para contra roldana	981930

MASTERMIG 500

REF.	ELENCO PEZZI DI RICAMBIO PIECES DETACHEES SPARE PARTS LIST ERSATZTEILLISTE PIEZAS DE REPUESTO	CODICE CODE KODE
64	Kit spina 8 poli Kit fiche 8 contacts 8 Pin plug kit 8 Pin steckerkit Kit enchufe 8 contactos	990226
65	Kit aspo Kit support bobine Reel kit Wickler kit Kit aspa	990264
66	Kit manopola Kit poignee Switch knob kit Schaltergriff kit Kit manija	990328
67	Kit presa Kit prise Socket kit Steckdosekit Kit tomacorriente	990330
68	Kit guaina entrata motore Kit gaine entree moteur Gas hose kit Drahtfuehrungsseelekit Kit vaina guiadera alambre	990097
69	Tappo per ruota Bouchon pour roue Wheel cap Rad stopfen Tapon rueda	322773
70	Rullino d. 1,2-1,6 Mm fe Galet d. 1,2-1,6 Mm fe Feed roll d. 1,2-1,6 Mm fe Vorschubrolle d. 1,2-1,6 Mm fe Roldana d. 1,2-1,6 Mm fe	722241
71	Rullino d. 1-1,2 Mm fe Galet d. 1-1,2 Mm fe Feed roll d. 1-1,2 Mm fe Vorschubrolle d. 1-1,2 Mm fe Roldana d. 1-1,2 Mm fe	742366
72	Protezione Protecion Cover Deckel Proteccion	322814
73	Adattatore Adapteur Adapter Zahnrad Adaptador	742166
74	Ingranaggio motore Engrenage motor Motor drive gear Motorszahnrad Engranaje motor	742348
75	Ingranaggio Engrenages Gears Zahnrad Engranaje	742590

REF.	ELENCO PEZZI DI RICAMBIO PIECES DETACHEES SPARE PARTS LIST ERSATZTEILLISTE PIEZAS DE REPUESTO	CODICE CODE KODE

REF.	ELENCO PEZZI DI RICAMBIO PIECES DETACHEES SPARE PARTS LIST ERSATZTEILLISTE PIEZAS DE REPUESTO	CODICE CODE KODE

Schema elettrico, Schéma électrique, Diagram, Schaltplan, Esquema de conexiones.

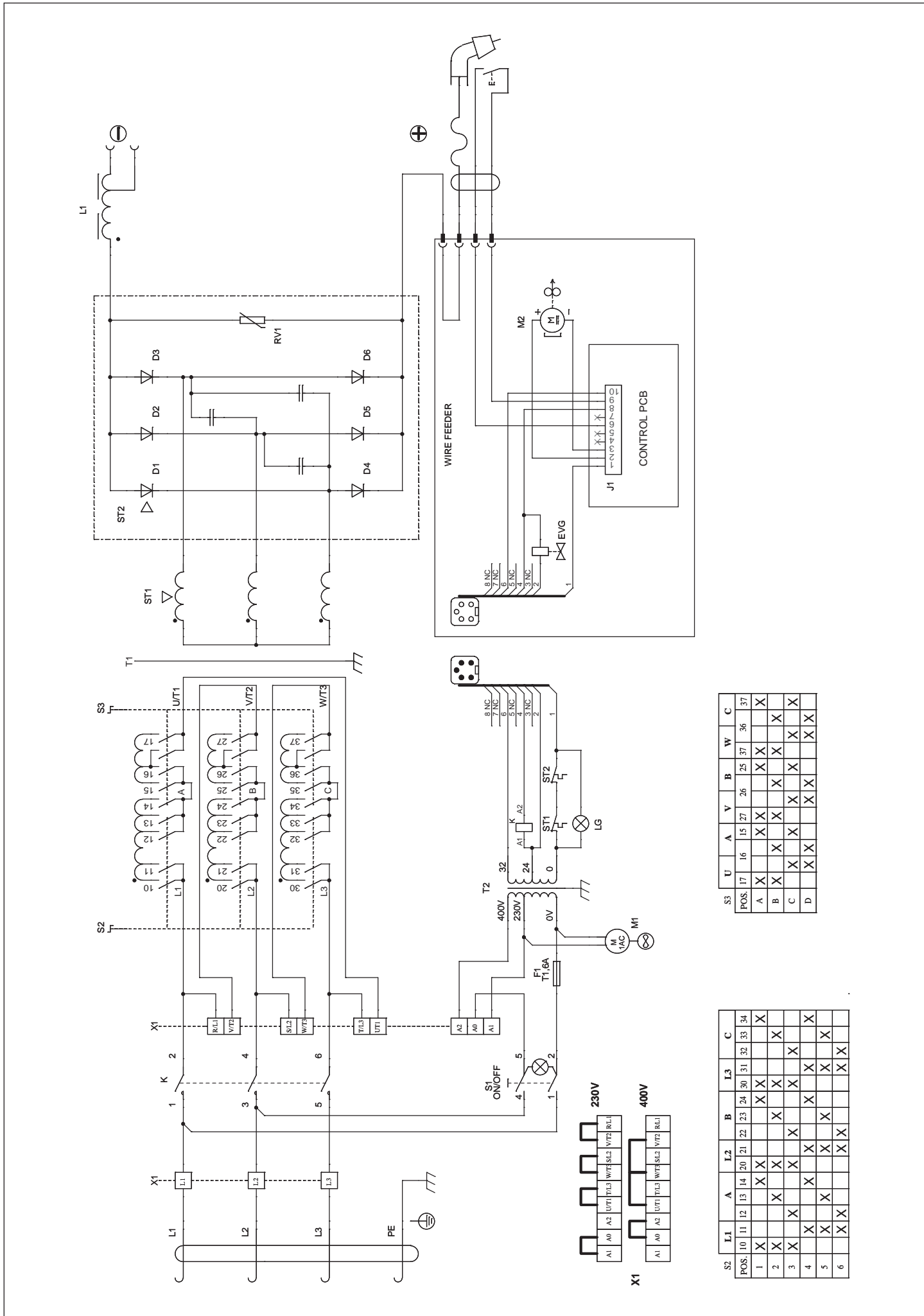

S3	U	A	V	B	W	C
POS. 17	16	15	27	26	25	37
A	X	X	X	X	X	X
B	X	X	X	X	X	X
C	X	X	X	X	X	X
D	X	X	X	X	X	X

S2	L1	A	L2	B	L3	C
POS. 10	11	12	13	14	20	21
1	X	X	X	X	X	X
2	X	X	X	X	X	X
3	X	X	X	X	X	X
4	X	X	X	X	X	X
5	X	X	X	X	X	X
6	X	X	X	X	X	X

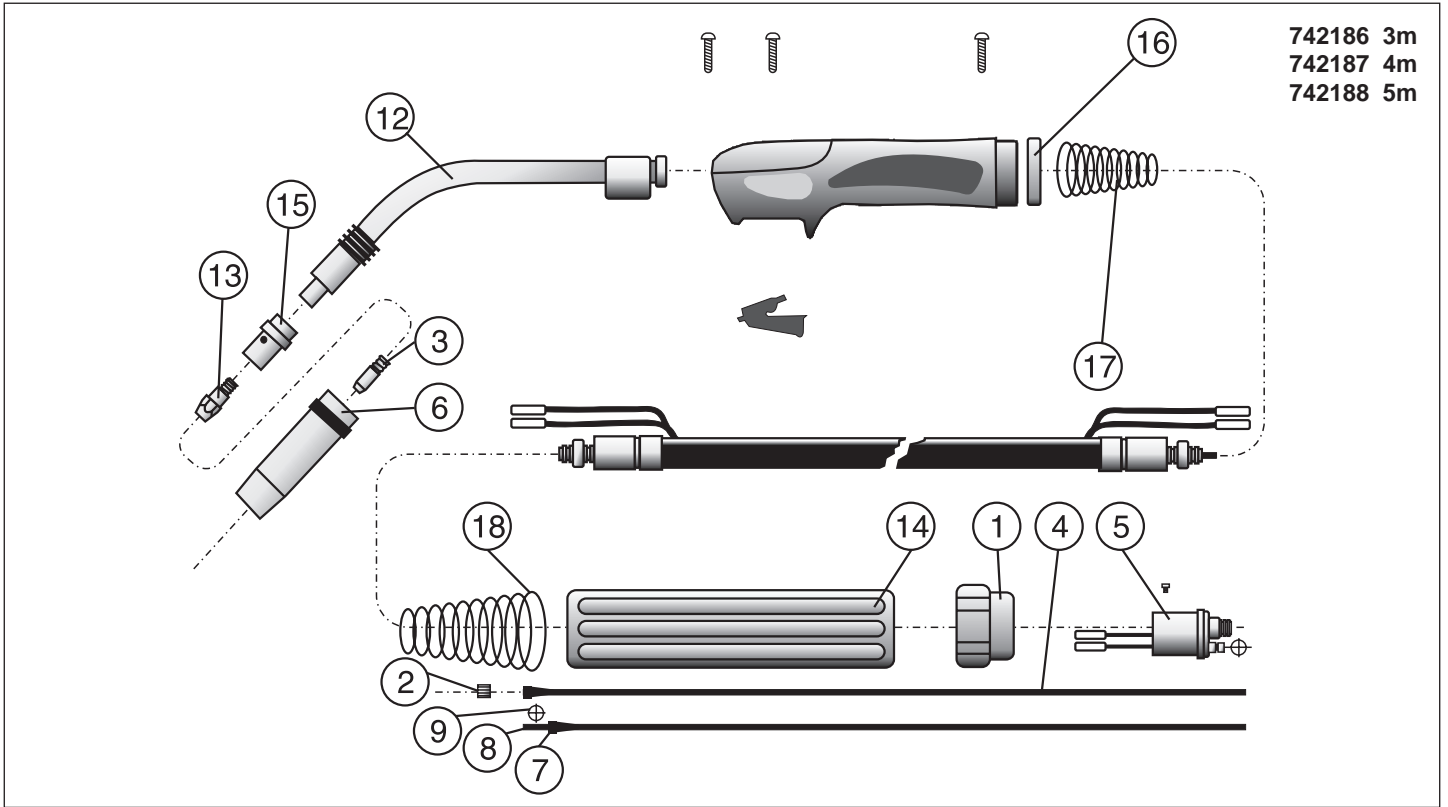

REF.	ELENCO PEZZI RICAMBIO TORCIA LISTE PIECES DETACHEES TORCHE SPARE PARTS LIST TORCH ERSATZTEILLISTE SCLAUCHPAKET PIEZAS DE REPUESTO ANTORCHA	CODICE CODE KODE
1	Ghiera Fissaggio Embout Fixage Ring Nut Nutmutter Virola Por Fijacion	722007
2	Dado Fissaggio Guaina Ecrou Fixage Gaine Liner Nut Befestigungsmutter Dado Por Fijacion Vaina	722013
3	Tubetto Di Contatto D. 0,6 Mm Tube Contact D. 0,6 Mm Contact Tip D. 0,6 Mm Kontaktroehrrchen D. 0,6 Mm Tubito De Contacto D. 0,6 Mm	722415
3	Tubetto Di Contatto Al/flux D. 1 Mm Tube Contact Al/flux D. 1 Mm Al/flux Contact Tip D. 1 Mm Al/flux Kontaktroehrrchen D.1 Mm Tubito De Contacto Al/flux D. 1 Mm	722552
3	Tubetto Di Contatto Al/flux D. 1,2 Mm Tube Contact Al/flux D. 1,2 Mm Al/flux Contact Tip D. 1,2 Mm Al/flux Kontaktroehrrchen D.1,2 Mm Tubito De Contacto Al/flux D. 1,2 Mm	722553
3	Tubetto Di Contatto D.0,8 Tube Contact D.0,8 Contact Tip D.0,8 Kontaktroehrrchen D.0,8 Tubito De Contacto D.0,8	722680
3	Tubetto Di Contatto D. 1 Mm Tube Contact D. 1 Mm Contact Tip D. 1 Mm Kontaktroehrrchen D. 1 Mm Tubito De Contacto D. 1 Mm	722681
3	Tubetto Di Contatto D. 1,2 Mm Tube Contact D. 1,2 Mm Contact Tip D. 1,2 Mm Kontaktroehrrchen D. 1,2 Mm Tubito De Contacto D. 1,2 Mm	722682
3	Tubetto Di Contatto D. 1,6 Mm Tube Contact D. 1,6 Mm Contact Tip D. 1,6 Mm Kontaktroehrrchen D. 1,6 Mm Tubito De Contacto D. 1,6 Mm	722797
3	Tubetto Di Contatto Al D. 1,6 Mm Tube Contact Al D. 1,6 Mm Contact Tip Al D. 1,6 Mm Kontaktroehrrchen Al D. 1,6 Mm Tubito De Contacto Al D. 1,6 Mm	722818
4	Guaina Guidafile D. 0,6-0,8 3M Gaine Pour Fil D. 0,6-0,8 3M Liner D. 0,6-0,8 3M Drahtfuehrungsseele D. 0,6-0,8 3M Vaina Guia Hilo D. 0,6-0,8 3M	722437
4	Guaina Guidafile D. 1,6-2 Mm Gaine Guide Fil D. 1,6-2 Mm Wire Guide Hose D. 1,6-2 Mm Drahtfuehrungsseele D. 1,6-2 Mm Vaine Guidera Alambre D. 1,6-2 Mm	722597

REF.	ELENCO PEZZI RICAMBIO TORCIA LISTE PIECES DETACHEES TORCHE SPARE PARTS LIST TORCH ERSATZTEILLISTE SCLAUCHPAKET PIEZAS DE REPUESTO ANTORCHA	CODICE CODE KODE
4	Guaina Guidafile D. 1-1,2 Mm 3 M Gaine Pour Fil D. 1-1,2 Mm 3 M Liner D. 1-1,2 Mm 3 M Drahtfuehrungsseele D. 1-1,2 Mm 3 M Vaina Guia Hilo D. 1-1,2 Mm 3 M	722689
4	Guaina Guidafile D. 1-1,2 Mm Gaine Pour Fil D. 1-1,2 Mm Wire Guide Hose D. 1-1,2 Mm Drahtfuehrungsseele D. 1-1,2 Mm Vaina Guia Hilo D. 1-1,2 Mm	742164
5	Corpo Torcia Corp De Torche Torch Assy Brennerskupplung Enganche Antorcha	722441
6	Ugello Conico Buse Conique Conical Nozzle Konische Duesse Inyector Conico	722792
6	Ugello Testa Fine Buse A Tete Fine Thin Headed Nozzle Verengte Duesse Inyector Cabeza Fina	722793
6	Ugello Puntatura Buse Pour Pointage Spot Welding Nozzle Punkschweisduesse Inyector Por Puntos	722794
7	Nipples Ferma Guaina Nipples Serre Gaine Wire Guide Locking Nipples Drahtseeleklemmnippel Nipples De Bloqueo Vaina	722598
7	Nippel Ferma Guaina Nippel Serre Gaine Wire Guide Locking Nipples Drahtseeleklemmnippel Nippel De Bloqueo Vaina	722599
8	Tubetto Ferma Guaina Tuyau Serre Gaine Wire Guide Locking Tube Drahtseeleklemmrohr Tubito De Bloqueo Vaina	722600
9	Anello Or Bague Or Or Ring Or Ring Anillo Or	722601
9	Anello Or Anneau Or Or Ring Or Ring Anillo Or	722606
12	Lancia Lance Swan Neck Brennerhals Encorvado	722788

REF.	ELENCO PEZZI RICAMBIO TORCIA LISTE PIECES DETACHEES TORCHE SPARE PARTS LIST TORCH ERSATZTEILLISTE SCLAUCHPAKET PIEZAS DE REPUESTO ANTORCHA	CODICE CODE KODE
13	Supporto Tubetto Contatto Support Tube Contact Contact Tip Holder Kontaktroehrrchenraeger Sosten Tubito De Contacto	722789
14	Attacco Torcia Attelage Torche Torch Connection Schlauchpaketanschluss Enganche Antorcha	742175
15	Diffusore Gas Isolante Diffuseur Gaz Gas Diffuser Gas Diffusor Difusor Gas	722791
16	Ghiera Per Torcia Embout Pour Torche Torch Ring Nut Brennermutter Virola Antorcha	742171
17	Supporto + Molla Torcia Support + Ressort Torche Torch Holder + Spring Brennerhalter + Feder Sosten Antorcha + Muelle	742173
18	Molla Torcia Ressort Torche Torch Spring Brennerfeder Muelle Antorcha	742174

Esploso torcia, Dessin torche, Torch drawing, Schlauchpaket - Explosionszeichnung, Diseño seccionado antorcha.

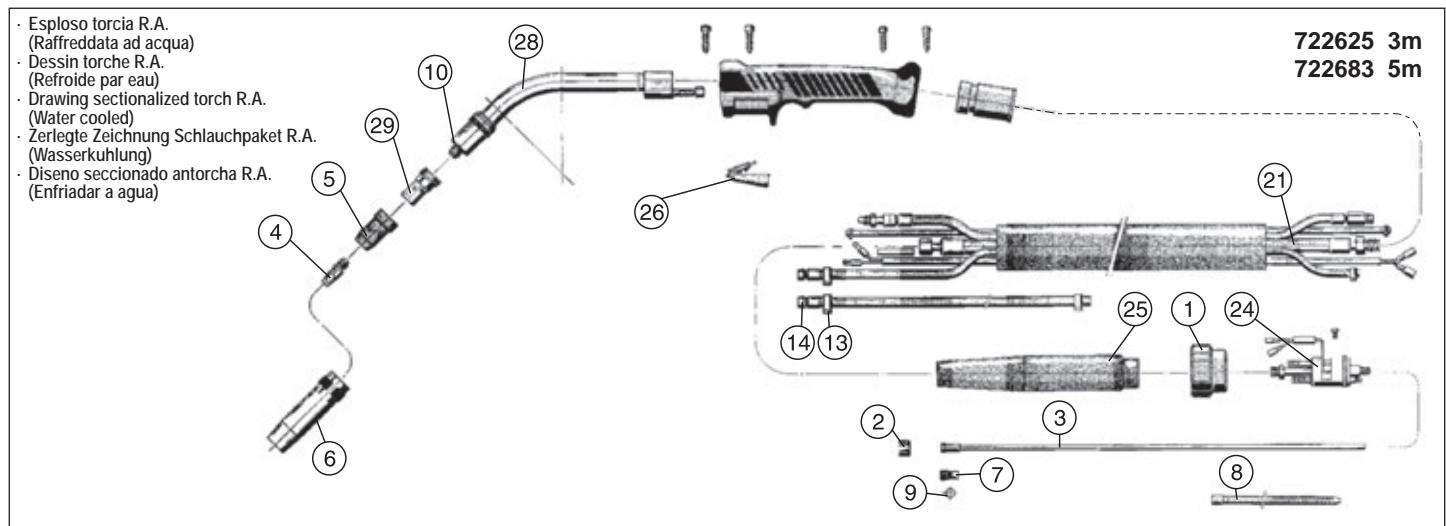

REF.	ELENCO PEZZI RICAMBIO TORCIA LISTE PIECES DETACHEES TORCHE SPARE PARTS LIST TORCH ERSATZTEILLISTE SCLAUCHPAKET PIEZAS DE REPUESTO ANTORCHA	CODICE CODE CODE
1	Ghiera Fissaggio Embout Fixage Ring Nut Nutmutter Virola Por Fiyacion	722007
2	Dado Fissaggio Guaina Ecrour Fixage Gaine Liner Nut Befestigungsmutter Dado Por Fiyacion Vaina	722013
3	Guaina Guidafile D. 1,2-1,6 Mm Gaine Pour Fil D. 1,2-1,6 Mm Liner D. 1,2-1,6 Mm Drahtführungsseele D. 1,2-1,6 Mm Vaina Guia Hilo D. 1,2-1,6 Mm	722588
3	Guaina Guidafile D. 1-1,2 Mm Gaine Pour Fil D. 1-1,2 Mm Liner D. 1-1,2 Mm Drahtführungsseele D. 1-1,2 Mm Vaina Guia Hilo D. 1-1,2 Mm	722590
3	Guaina Guidafile D. 1,6-2 Mm Gaine Guide Fil D. 1,6-2 Mm Wire Guide Hose D. 1,6-2 Mm Drahtführungsseele D. 1,6-2 Mm Vaine Guidadera Alambre D. 1,6-2 Mm	722597
3	Guaina G.f. D.2-2,4 Mt.3 Gaine Guide Fil D.2-2,4 M3 Wire Guide Hose D.2-2,4 M3 Drahtführungsseele D.2-2,4 M3 Vaina Guidadera Alambre D. 2-2,4 M3	722820
3	Guaina Guidafile D. 1-1,2 Mm Gaine Pour Fil D. 1-1,2 Mm Wire Guide Hose D. 1-1,2 Mm Drahtführungsseele D. 1-1,2 Mm Vaina Guia Hilo D. 1-1,2 Mm	742164
4	Tubetto Contatto D.0,8 Tube Contact D.0,8 Contact Tip D.0,8 Kontaktroehrchen D.0,8 Tubito De Contacto D.0,8	722581
4	Tubetto Contatto D.1,0 Tube Contact D.1,0 Contact Tip D.1,0 Kontaktroehrchen D.1,0 Tubito De Contacto D.1,0	722582
4	Tubetto Contatto D.1,2 Tube Contact D.1,2 Contact Tip D.1,2 Kontaktroehrchen D.1,2 Tubito De Contacto D.1,2	722583
4	Tubetto Contatto D.2,0 Tube Contact D.2,0 Contact Tip D.2,0 Kontaktroehrchen D.2,0 Tubito De Contacto D.2,0	722586
4	Tubetto Contatto D.1,6 Tube Contact D.1,6 Contact Tip D.1,6 Kontaktroehrchen D.1,6 Tubito Di Contacto D.1,6	722587
4	Tubetto Di Contatto Flux D.1 Mm Tube Contact Flux D.1 Mm Flux Contact Tip D.1 Mm Flux Kontaktroehrchen D.1 Mm Tubito De Contacto Flux D.1 Mm	722769
4	Tubetto Di Contatto Flux D.1,2 Mm Tube Contact Flux D.1,2 Mm Contact Tip Flux D.1,2 Mm Kontaktroehrchen Flux D.1,2 Mm Tubito De Contacto Flux D.1,2 Mm	722770
4	Tubetto Di Contatto Flux D.1,6 Mm Tube Contact Flux D.1,6 Mm Contact Tip Flux D.1,6 Mm Kontaktroehrchen Flux D.1,6 Mm Tubito De Contacto Flux D.1,6 Mm	722771

REF.	ELENCO PEZZI RICAMBIO TORCIA LISTE PIECES DETACHEES TORCHE SPARE PARTS LIST TORCH ERSATZTEILLISTE SCLAUCHPAKET PIEZAS DE REPUESTO ANTORCHA	CODICE CODE CODE
4	Tubetto Di Contatto Al/flux D.2 Mm Tube Contact Al/flux D.2 Mm Contact Tip Al/flux D.2 Mm Kontaktroehrchen Al/flux D.2 Mm Tubito De Contacto Al/flux D.2 Mm	722772
4	Tubetto Di Contatto D. 2,4 Mm Tube Contact D. 2,4 Mm Contact Tube D. 2,4 Mm Kontaktroehrchen D. 2,4 Mm Tubito De Contacto D. 2,4 Mm	722773
4	Tubetto Di Contatto Al D.1 Mm Tube Contact Al D.1 Mm Contact Tip Al D.1 Mm Kontaktroehrchen Al D.1 Mm Tubito De Contacto Al D.1 Mm	742159
4	Tubetto Di Contatto Al D.1,2 Mm Tube Contact Al D.1,2 Mm Contact Tip Al D.1,2 Mm Kontaktroehrchen Al D.1,2 Mm Tubito De Contacto Al D.1,2 Mm	742160
4	Tubetto Di Contatto Al D.1,6 Mm Tube Contact Al D.1,6 Mm Contact Tip Al D.1,6 Mm Kontaktroehrchen Al D.1,6 Mm Tubito De Contacto Al D.1,6 Mm	742161
5	Isolante Diffusore Gas Douille Isolante Gas Diffuser Insulation Gasdiffuser Isolierteil Aislador Difusor Gas	722593
6	Ugello Conico Buse Conique Conical Nozzle Konische Duese Inyector Conico	722585
6	Ugello Puntatura Buse Pointage Spot Welding Nozzle Punktschweissduese Inyector Por Puntos	722594
6	Ugello Cilindrico Buse Cylindrique Cylindrical Nozzle Zylindrische Duese Inyector Cilindrico	722595
7	Nipples Ferma Guaina Nipples Serre Gaine Wire Guide Locking Nipples Drahtseelekllemnippel Nipples De Bloqueo Vaina	722598
7	Nippel Ferma Guaina Nippel Serre Gaine Wire Guide Locking Nipples Drahtseelekllemnippel Nippel De Bloqueo Vaina	722599
8	Tubetto Ferma Guaina Tuyau Serre Gaine Wire Guide Locking Tube Drahtseeleklmrohr Tubito De Bloqueo Vaina	722600
9	Anello Or Bague Or Or Ring Or Ring Anillo Or	722601
9	Anello Or Anneau Or Or Ring Or Ring Anillo Or	722606
10	Rondella Isolante Rondelle Isolante Insulating Washer Isolierschraube Arandela Aislante	722603

REF.	ELENCO PEZZI RICAMBIO TORCIA LISTE PIECES DETACHEES TORCHE SPARE PARTS LIST TORCH ERSATZTEILLISTE SCLAUCHPAKET PIEZAS DE REPUESTO ANTORCHA	CODICE CODE CODE
13	Fascetta Collier Hose Ring Schelle Cintura	232114
14	Riduzione Innesti Rapidi Reducteur Reduction Schnelle Kupplungreduktion Reduccion Inyertos Rapidos	722608
21	Cavo Acqua/corrente Mt.3 Cable Eau 3 M Water Pipe 3M Wasser Kabel 3M Cabel Por Agua 3M	722615
24	Corpo Torcia Posteriore Partie Torche Posterieure Back Torch Part Hinterschlauchpaket Cuerpo De Antorcha Posterior	722619
25	Copri Adattatore Completo Couvre Adaptateur Complet Complete Adaptor Cover Brennerkupplungdeckel Proteccion De Enganche	722621
26	Pulsante Poussoir Pushbutton Druckknopf Pulsador	722677
28	Lancia Lance Swan Neck Brennerhals Encorvado	722708
29	Supporto Tubetto Contatto Suport Tube Contact Contact Tip Holder Kontaktroehrcentraeger Sosten Tubito De Contacto	722709