

ST WITH METER AND FILTER

FEATURES

- **READY TO USE**
- **VERSATILE**
- **EASY TO INSTALL**
- **COMPACT DESIGN**
- **FILTRATION GUARANTEED**
- **AVAILABLE WITH DIFFERENT PUMPS**

PIUSI ST WITH METER AND FILTER is a range of dispensers particularly suited for all applications in which a filtration is required. The stations integrate PIUSI CLEAR or WATER CAPTOR FILTERS and are available with mechanical meter K33 or electronic meter K24/K600 B/3. They come with integrated check valve and 4-meter delivery hose.

PERFORMANCE

UP TO 90 L/MIN	AC CONTINUOUS DUTY POWER
FLOW RATE	
± 1%	UP TO 6MT LENGHT DELIVERY HOSE
ACCURACY	



ST PANTHER 56, K33, A60 E WATER CAPTOR

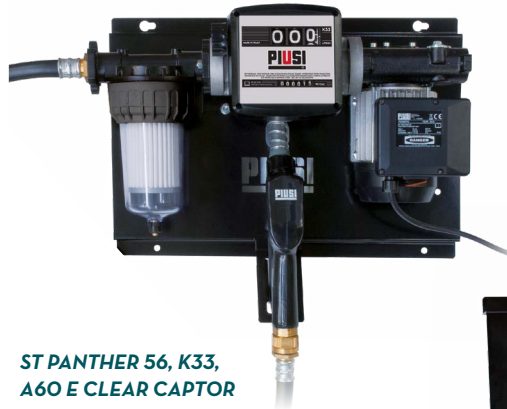

ST PANTHER 56, K33, A60 E CLEAR CAPTOR



ST PANTHER 72, K33, A70 - BIODIESEL FILTER



PACKAGING

CODE	WEIGHT		PACKAGING		
	KG	LBS	MM	INCH	PCS/BOX
FOO386FOA	25	55	580X380X320	22,8X15X12,6	1
FOO265FOA	26	57	580X380X320	22,8X15X12,6	1
FOO395FOA	32	71	545X435X340	21,5X17,1X13,4	1
FOO386F60	22	48	380X380X480	15X15X18,9	1
FOO386R70	22	48	380X380X480	15X15X18,9	1
FOO265F40	26	57	580X380X320	22,8X15X12,6	1
FOO265S80	26	57	580X380X320	22,8X15X12,6	1
FOO395F60	32	71	545X435X340	21,5X17,1X13,4	1
FOO265S20	18	40	480X370X260	18,9X14,6X10,2	1
FOO265R70	18	40	480X370X260	18,9X14,6X10,2	1
FOO395B00	29	63	560X450X370	22X17X14,5	1
FOO265B00	21	46	580X400X340	22,8X15,7X13,3	1



AVAILABLE WITH DIFFERENT PUMPS AND METERS



AC PUMP - PANTHER 56/72
PANTHER 72 BIO

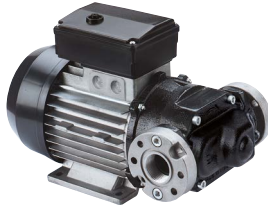

AC PUMP - E120
E120 BIO



AUTOMATIC NOZZLES
AUTOMATIC NOZZLES BIO



MECHANICAL METER - K33
K33 BIO



ELECTRONIC METER. - K24



ELECTRONIC METER - K600 B/3

DIMENSIONS

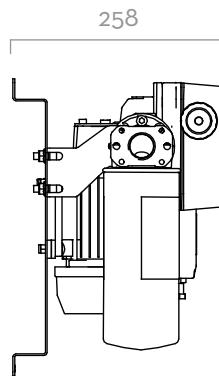
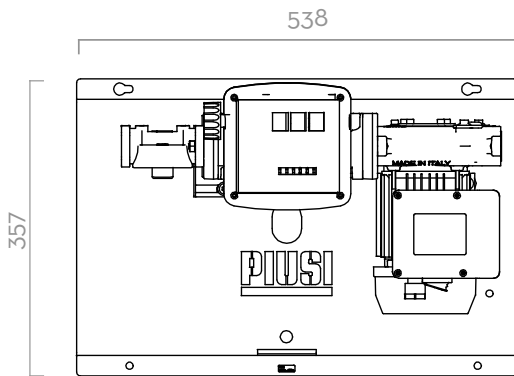

Dimensions expressed in millimeters

IN THE BOX

- ST WITH METER AND FILTER
- METER
- FILTER
- DELIVERY HOSE
- NOZZLE
- NOZZLE HOLDER
- INSTRUCTION MANUAL

DETAILS



WATER CAPTOR FILTER
/ BIODIESEL FILTER



MAN. / AUTOM. NOZZLE



K24 / K600 B/3 METER



K33 METER

COMPONENTI

- PUMPS:
PANTHER AC
E80/E120
- NOZZLE:
PISTOLA AUTOM.
- METER:
K33
K24
K600 B/3
- FILTER
WATER CAPTOR

TECHNICAL DATA

CODE	DESCRIPTION	FLUIDS TYPE	FLOW RATE		VOLTAGE			METER	NOZZLE	FILTER	DELIVERY HOSE	SUCTION HOSE	INLET		
			L/MIN	GPM	AC V/ HZ	DC VOLT	POWER WATT							AMP. MAX.	LENGTH
FOO386FOA	ST PANTHER 56 FILTER + A6O	D	52	14	230/50	350	3	K33	A6O	YES	NO	6M	3/4"	4M	1"
FOO265FOA	ST PANTHER 72 FILTER + A6O	D	70	18	230/50	500	4,2	K33	A6O	YES	NO	6M	3/4"	4M	1"
FOO395FOA	ST E120 FILTER + A12O	D	85	22	230/50	1150	5,7	K33	A12O	YES	NO	6M	1"	4M	1"
FOO386F6O	ST PANTHER 56 FILTER + A6O	D	52	14	230/50	350	3	K33	A6O	YES	NO	6M	3/4"	-	-
FOO386R7O	ST PANTHER 56 + CLEAR CAPTOR + A6O	D	52	14	230/50	350	3	K33	A6O	YES	NO	6M	3/4"	-	-
FOO265F4O	ST PANTHER 72 FILTER + A6O	D	70	18	230/50	500	4,2	K33	A6O	YES	NO	6M	3/4"	-	-
FOO265S8O	ST PANTHER 72 K600 B/F/6T/PA6O	D	70	18	230/50	500	4,2	K600 B/3	A6O	YES	NO	6M	1"	-	-
FOO395F6O	ST E 120 FILTER + A12O	D	85	22	230/50	1150	5,7	K33	A12O	YES	NO	6M	1"	-	-
FOO265S2O	ST PANTHER 72 FILTER + K24 METER	D	70	18	230/50	500	4,2	K24	A8O	YES	NO	6M	3/4"	-	-
FOO265R7O	ST PANTHER 72 + CLEAR CAPTOR + A8O	D	70	18	230/50	500	4,2	K24	A8O	YES	NO	6M	1"	-	-
NEW FOO395B0O	ST E120 K15O/F/6MT/PA12O B10O	BIO D	85	22	230/50	1150	5,7	K15O B1O	A12O B1O	NO	YES	6M	1"	-	-
NEW FOO265B0O	ST PANTHER 72 K33/F/6MT/PA7O B10O	BIO D	70	18	230/50	500	4,2	K33 B1O	A7O B1O	NO	YES	6M	3,4"	-	-