



FUEL MANAGEMENT SYSTEMS



DISPENSERS



KITS



PUMPS



METERS



NOZZLES

EX50 DRUM

FEATURES

- STURDY STRUCTURE
- FLANGED COMPONENTS
- ANTI-NOISE FILTER
- THERMAL PROTECTION
- BUILT-IN BYPASS VALVE
- SUCTION PIPE WITH INTEGRATED FILTER
- UL LISTED VERSION AVAILABLE

The PIUSI EX50 DRUM is a complete pump transfer kit expressly engineered for ATEX/IECEx areas. This system is composed of a high-efficiency pump, manual or automatic nozzle and a telescopic suction hose. Thanks to the flanged components, this transfer set allows users to replace any component without using sealants thus creating maximum versatility and adaptability to any kind of condition. K33 mechanical meter available on request.



PIUSI EX50 DRUM WITH METER AND FILTER



PERFORMANCE

UP TO
50 L/MIN

FLOW RATE

1100 MM

SUCTION PIPE

±1%

ACCURACY

200β/30μ

FILTERING CAPACITY



EX50 DRUM WITH AUTOMATIC NOZZLE



EX50 DRUM WITH MANUAL NOZZLE

OUR PUMPS COMPLIES WITH THE FOLLOWING MARKING ATEX/IECEx

II	2	G	Ex	d	IIA	T4	Gb
GROUP	CATEGORY	TYPE OF EXPLOSIVE ATMOSPHERE	PERMANENT PREFIX	PROTECTION METHOD	GAS GLASS	TEMPERATURE CLASS	EQUIPMENT PROTECTION LEVEL

PACKAGING

CODE	WEIGHT		PACKAGING			
	KG	LBS	MM	INCH	PCS/BOX	
WITHOUT METER						
FO0372000	10	22	600X400X290	23,6X13,7X11,4	1	
FO0372010	10	22	600X400X290	23,6X13,7X11,4	1	
FO0372020	7,9	17,4	345X175X225	-	1	
WITH METER						
FO037500A	12	22	600X400X290	23,6X13,7X11,4	1	
FO037501A	12	22	600X400X290	23,6X13,7X11,4	1	



FILTRATION



TANK MONITORING



HOSE REEL



ACCESSORIES



MERCHANDISE

PIUSI

INDEX

BIS

ANY BIODIESEL

A

AIR

A

ANTIFREEZE

Ad

AdBlue®

B

BIODIESEL

D

DIESEL

F

FOOD

G

GASOLINE

G

GREASE

K

KEROSENE

O

OIL

W

WATER

W

WINDSCREEN

CHART

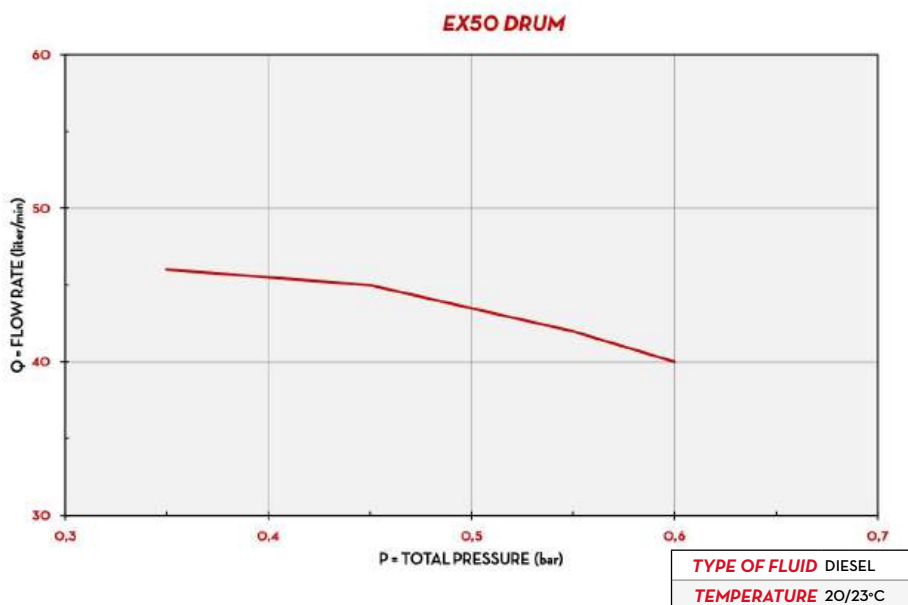

IN THE BOX

- EX50 PUMP
- TELESCOPIC SUCTION PIPE
- DELIVERY HOSE
- WATER CAPTOR FILTER
- A60 ATEX NOZZLE
- 2" CONNECTOR
- K33 ATEX METER (ON SELECTED VERSION)
- INSTRUCTION MANUAL

DETAILS



DIMENSIONS

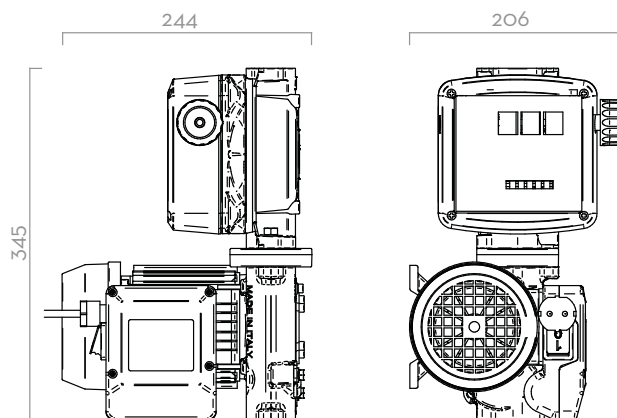

Dimensions expressed in millimeters

COMPONENTS

- **PUMP:**
EX50
- **METER:**
K33 ATEX
- **NOZZLE:**
A60 ATEX
SELF3000
- **FILTER:**
WATER CAPTOR

TECHNICAL DATA

CODE	DESCRIPTION	FLUIDS TYPE	FLOW RATE		VOLTAGE			METER	NOZZLE	FILTER	INLET	HOSE	
			L/MIN	GPM	AC V/ HZ	DC VOLT	POWER WATT					AMP. MAX.	BSP
WITHOUT METER													
FO0372000	DRUM EX50 12V DC ATEX + MAN. NOZZLE	B G K	50	13	12	250	21	-	SELF3000	YES	1"	4	3/4"
FO0372010	DRUM EX50 12V DC ATEX + AUT. NOZZLE	B G K	50	13	12	250	21	-	A60	YES	1"	4	3/4"
FO0372020	KIT DRUM EX50 12V DC ATEX	B G K	50	13	12	250	21	-	NO	NO	1"	-	-
WITH METER													
FO037500A	DRUM EX50 12V DC K33 ATEX + MAN. NOZZLE	B G K	50	13	12	250	21	K33	SELF3000	YES	1"	4	3/4"
FO037501A	DRUM EX50 12V DC K33 ATEX + AUT. NOZZLE	B G K	50	13	12	250	21	K33	A60	YES	1"	4	3/4"

() UPON REQUEST IT IS AVAILABLE WITH DIFFERENT VOLTAGES AND 60 HZ FREQUENCY. COMPATIBLE FLUIDS: DIESEL, KEROSENE, PETROL, PETROL ALCOHOL MIXED MAX 15%, AVGAS 100/100LL (ONLY PUMP&METER), JET A/A1 (ONLY PUMP&METER), ASPEN 2/4