

Operating Instructions

— Pneumatic Notching Machine

— AKM 130-3 P

— AKM 150-2 P



AKM 130-3 P

AKM 130-3/150-2

Imprint

Product identification

Pneumatic Notching Machine	Item number
AKM 130-3 P	3833130
AKM 150-2 P	3832150

Manufacturer

Stürmer Maschinen GmbH
Dr.-Robert-Pfleger-Str. 26
D-96103 Hallstadt

Fax: 0049 (0) 951 96555 - 55
E-Mail: info@metallkraft.de
Internet: www.metallkraft.de

Indications regarding the operating instructions

Original operating instructions

Edition 14.02.2019
Version: 1.07
Language: English

Author: FL/KP

Indications regarding the copyright

Copyright © 2019 Stürmer Maschinen GmbH, Hallstadt, Germany.

The content of these operating instructions is the sole property of the company Stürmer Maschinen GmbH. Passing on as well as copying of this document, the use and distribution of its content are prohibited if not explicitly permitted. Contraventions are liable to compensation.

Subject to technical modifications and errors.

Contents

1 Introduction	3
1.1 Copyright.....	3
1.2 Customer service.....	3
1.3 Limitation of liability	3
2 Safety.....	3
2.1 Symbol explanation	3
2.2 Obligations of the operating company	4
2.3 Requirements to staff.....	4
2.4 Personal protective equipment.....	5
2.5 General safety regulations.....	5
2.6 Safety labels on the notching machine	6
2.7 Safety devices	6
3 Intended Use.....	7
3.1 Improper use	7
3.2 Residual risks	7
4 Technical Data	7
4.1 Table.....	7
4.2 Type plate.....	8
5 Transport, packaging, storage.....	8
5.1 Delivery and transport	8
5.2 Packaging.....	9
5.3 Storage	9
6 Description of device	9
6.1 Representation	9
6.2 Scope of delivery.....	10
6.3 Accessories	10
7 Installation	10
7.1 Requirements for the location.....	10
7.2 Unpacking and setting up	11
7.3 Electrical connection	12
7.4 Connecting the compressed air	12
8 Settings	12
8.1 Setting of the cutting gap	12
8.2 Replace of the knife.....	14
8.3 Cutter bar-Stroke limit.....	15
8.4 Setting the limit stops	15
9 Operation	16
9.1 Initial operation	17
9.2 Workflow	17
9.3 Switching off the machine	17
10 Care, maintenance and repair	18
10.1 Cleaning and lubricating the machine	18
10.2 Maintenance of the machine	19
11 Disposal, recycling of used device.....	19
11.1 Decommissioning.....	19
11.2 Waste disposal of electric equipment	19
11.3 Disposal of lubricants.....	19
12 Disturbances, possible causes and measures ...	20
13 Spare parts.....	20
13.1 Spare parts ordering	20
13.2 Spare parts drawing	21
14 Pneumatic plan	22
15 EC Declaration of Conformity	23

1 Introduction

You have made a good choice by purchasing the notching machine made by METALLKRAFT.

Thoroughly read the operating instructions before commissioning the machine.

It informs you about the proper commissioning, the intended use as well as the safe and efficient operation and maintenance of your notching machine.

The operating instructions are part the notching machine. Always keep it at the place of use the notching machine. Furthermore, the local accident prevention regulations and the general safety notes are applicable for the field of application the notching machine.

The illustrations in these operating instructions serve the general comprehension and may deviate from the actual type.

1.1 Copyright

The contents of these instructions are copyright. Their application is admissible in the frame the notching machine utilisation. An application beyond the described application is not allowed without written approval of the manufacturer. For the protection of our products, we shall register trademark, patent and design rights, as this is possible in individual cases. We strongly oppose any infringement of our intellectual property.

1.2 Customer service

Please contact your dealer if you have questions concerning your notching machine or if you need technical advice. They will help you with specialist information and expert advice.

Germany:

Stürmer Maschinen GmbH
Dr.-Robert-Pfleger-Str. 26
D-96103 Hallstadt

Repair service :

Fax: 0049 (0) 951 96555-111
E-Mail: service@stuermer-maschinen.de

Spare part orders:

Fax: 0049 (0) 951 96555-119
E-Mail: ersatzteile@stuermer-maschinen.de

We are always interested in valuable experience and knowledge gained from using the application-which then could be shared and be valuable to develop our products even further.

1.3 Limitation of liability

All information and notes in these operating instructions were summarised taking the applicable standards and rules, the state-of-the-art and our long-term knowledge and experiences into consideration.

In the following cases the manufacturer is not liable for damages:

- Non-observance of the operating instructions,
- Inappropriate use,
- Use of untrained staff,
- Unauthorised modifications,
- Technical changes,
- Use of not allowed spare parts.

The actual scope of delivery may deviate from the explanations and presentations described here in case of special models, when using additional ordering options or due to latest technical modifications.

The obligations agreed in the delivery contract, the general terms and conditions as well as the delivery conditions of the manufacturer and the legal regulations at the time of the conclusion of the contract are applicable.

2 Safety

This paragraph will give you an overview of all important safety packages for the protection of persons as well as for the safe and undisturbed operation. Other task-based safety notes are included in the individual chapters.

2.1 Symbol explanation

Safety instructions

The safety notes in these operating instructions are highlighted by symbols. The safety notes are introduced by signal words which express the concern of the risk.



DANGER!

This combination of symbol and signal words indicate an imminently dangerous situation which may lead to death or severe injuries if they are not avoided.



WARNING!

This combination of symbol and signal words indicate a possibly dangerous situation which may lead to death or severe injuries if they are not avoided.

**CAUTION!**

This combination of symbol and signal words indicate a possibly dangerous situation which may lead to minor or light injuries if they are not avoided.

**NOTE !**

This combination of symbol and signal words indicate a possibly dangerous situation which may lead to property and environmental damages if they are not avoided.

Tips and recommendations**Tips and recommendations**

This symbol highlights useful tips and recommendations as well as information for an efficient and trouble-free operation.

It is necessary to observe the safety notes quoted in these operating instructions in order to reduce the risks for personal injuries and damages to property.

2.2 Obligations of the operating company

The operating company is the person who operates the the notching machine for business or commercial reasons by herself, or leaves it to a third party for use or application, and who bears the legal product responsibility for the protection of the user, the staff or for third parties.

Obligations of the operating company

If the the notching machine is used for commercial purposes, the operating company of the notching machine must comply with the legal working safety regulations.

Therefore, the safety notes in this operating manual, as well as the safety, accident prevention and environment protection regulations applying for the area of application of the notching machine must be met. The following applies in particular:

- The operating company must be informed about the applying industrial safety regulations and further analyse hazards resulting from the special working conditions at the place of use of the notching machine. She must implement these in form of operating manuals for the operation of the notching machine.
- During the entire lifetime the notching machine, the operating company must verify whether the operating manuals prepared by her correspond to

the current status of the regulations, and must adapt these if necessary.

- The operating company must unambiguously regulate and determine the responsibilities for installation, operation, troubleshooting, maintenance and cleaning.
- The operating company must ensure that all persons who work with the notching machine, have read and understood this manual. Furthermore she must instruct the staff in regular intervals and inform them about the hazards.
- The operator must provide the necessary protective equipment to the staff and order the use of the necessary protective equipment in a binding way.

Furthermore the operating company is responsible to keep the notching machine always in a technically flawless state. Thus, the following applies:

- The operator must ensure that the maintenance intervals described in this manual are kept.
- The operator must have all safety devices checked regularly for their good working order and their integrity.

2.3 Requirements to staff**Qualifications**

The different tasks described in this manual represent different requirements to the qualification of the persons entrusted with these tasks.

**WARNING!****Danger in case of insufficient qualification of the staff!**

Insufficiently qualified persons cannot estimate the risks while using the notching machine and expose themselves and others to the danger of severe or lethal injuries.

- Have all works only performed by qualified persons.
- Keep insufficiently qualified persons out of the working area.

Only persons reliable working procedures can be expected from, are allowed to perform all works. Persons the responsiveness of which is affected by e. g. drugs, alcohol or medication, are not allowed to work with the machine.

The qualifications of the personnel for the different tasks are mentioned below:

Operator

The operator is instructed by the operating company about the assigned tasks and possible risks in case of improper behaviour. Any tasks which need to be performed beyond the operation in the standard mode must only be performed by the operator if it is indicated in these instructions and if the operating company expressly commissioned the operator.

Electrically qualified person

Electrically qualified person is due to their professional training, knowledge and experience as well as knowledge of the relevant standards and regulations, in a position to carry out work on the electrical systems and to independently recognize and avoid possible dangers.

Qualified personnel

Due to their professional training, knowledge and experience as well as their knowledge of relevant regulations the specialist staff is able to perform the assigned tasks and to recognise and avoid any possible dangers themselves.

Manufacturer

Certain works may only be performed by specialist personnel of the manufacturer. Other personnel is not authorized to perform these works. Please contact our customer service for the execution of all arising work.

2.4 Personal protective equipment

The personal protective equipment serves to protect persons against impairments of safety and health while working. The staff has to wear personal protective equipment while performing different works on and with the notching machine which are indicated in the individual paragraphs of these instructions.

The personal protective equipment is explained in the following paragraph:



Protective goggles

The goggles protect the eyes from flying parts and liquid splashes



Hearing protection

The hearing protection protect the ears from hearing damage caused by noise..



Breathing protection

Breathing protection serve to protect the respiratory tract and lungs from the absorption of dust particles.



Protective gloves

The protective gloves serve to protect the hands against sharp components as well as against friction, abrasions or deep injuries.



Safety boots

Safety boots protect the feet from being crushed, falling parts and slipping over on slippery ground.



Protective clothes

Protective clothes are made of a tightly fitted fabric without the protruding parts of low tear strength.

2.5 General safety regulations

Please observe the following points:

- Use the guards and secure them securely. Never work without guards and keep them functional.
- Always keep the machine and its working environment clean. Provide adequate lighting.
- Always secure your workpiece when working with suitable clamping devices. Ensure a sufficient contact surface.
- The design of the notching machine must not be changed and it must not be used for purposes other than those foreseen by the manufacturer.
- Never work under the influence of illnesses that impair concentration, drugs, alcohol or medication.
- Keep children and persons unfamiliar with the notching machine away from their work environment.
- Immediately eliminate malfunctions that reduce safety.
- Protect the notching machine against humidity (short-circuit hazard!)
- Before each use of the notching machine, make sure that no parts are damaged. Damaged parts must be replaced immediately to avoid sources of danger.
- Do not overload the notching machine. You will work better and safer in the specified performance range.
- Never cut material with a thickness or characteristics that differ from the technical data of the machine.
- Use only original spare parts and accessories to avoid possible dangers and accident risks..
- Before starting the machine, make sure that there are no dangerous environmental conditions for the operator which could pose a danger during operation.
- Make sure that there are no tools or objects inside or on the machine before starting the machine.
- Keep the worktable and work area clean and clear to prevent any obstruction caused by cut material.
- Check that the fixed hand guards are properly installed.

2.6 Safety labels on the notching machine

The following safety labels and instructions are attached to the notching machine (Fig. 1) and must be observed.

	Luft Aufbereitung / AIR UNIT MACP300-10A Maximaler Druck 9,9 kgf/cm ² Temp. -5°C--+60°C (KEIN einfrieren) Max. pressure 9,9 kgf/cm ² Temp -5°C--+60°C (NO freezing)
	<ul style="list-style-type: none"> • Verwenden Sie ein gleichwertiges Öl - ISO-VG32 • Von flüchtigen Stoffen wie Verdünnern und Trichloräthen fernhalten • Von direkter Sonneneinstrahlung fernhalten • Use Oil ISO-VG32 Equivalent • Kept off volatility environment like thinner and trichloroethylene • Kept off direct sunrays
Die Schutzabdeckung NICHT bei laufendem Betrieb entfernen. Wird dieser Warnhinweis nicht befolgt, können schwerwiegende Verletzungen die Folge sein. DO NOT remove the safety cover under operation. Failure to follow warning may result in serious injury.	

Befolgen Sie bitte nachstehende Anweisungen: <ul style="list-style-type: none"> • Bedienen Sie die Maschine niemals, wenn Sie nicht über die notwendigen Kenntnisse verfügen. • Öffnen oder entfernen Sie niemals Schutzabdeckungen bei laufendem Betrieb. • Halten Sie Ihre Hände fern von sich bewegenden Teilen oder sich bewegendem Material. • Bedienen Sie die Maschine nicht unter Einfluss von Drogen, Alkohol oder Medikamenten. • Warten Sie die Maschine niemals bei laufendem Motor. • Lesen und verinnerlichen Sie die Bedienungsanleitung vor der Anwendung. • Werden diese Warnhinweise nicht befolgt, können schwerwiegende Verletzungen die Folge sein.
DO NOT'S: <ul style="list-style-type: none"> • Never operate machine unless properly trained. • Never open or remove guards until machine is stopped. • Never place hands in area near moving parts or moving material. • Do not operate while under influence of drugs, alcohol, or medication. • Never service machine with motor on. • Read and understand the instruction manual before operation. • Failure to heed these warnings can result in serious injury.

WICHTIG! IMPORTANT!
Bitte schmieren Sie die Maschine regelmäßig an dafür vorgesehenen Schmierstellen. Please lubricate the machine from lubrication points periodically.



Schmierstelle Lubrication injection point

Fig. 1: Safety labels and instructions

Bitte trennen Sie die Luft- oder Stromversorgung vor allen Service- oder Wartungsarbeiten. Wird dieser Warnhinweis nicht befolgt, können schwerwiegende Verletzungen die Folge sein. Before making any service or maintenance, please make sure air or electric power supply is disconnected. Failure to follow caution may result in serious injury.

Die Schutzabdeckung NICHT entfernen und die Hände während des Betriebs und Schneidvorgangs von der Maschine fern halten. DO NOT remove the protection guard and keep hands away during operation and cutting.

Fig. 2: Safety labels and instructions

The safety markings which are applied on the machine must not be removed. Damaged or missing safety markings may lead to errors, personal and material damages. Immediately replace them.

Decommission the machine if the security symbols cannot be recognised nor understood at the first glance, until the new security symbols are applied.

2.7 Safety devices

	WARNING! Danger to life due to non-functioning safety devices!
--	---

If the safety devices are not functioning or have been rendered inoperative, there is a risk of serious injury or even death.

- Before starting work, check that all safety devices are functional and correctly installed.
- Never bypass or disable the safety devices.
- Ensure that all safety devices are always accessible.

	WARNING! Risk of uncontrolled restart!
--	---

The uncontrolled restart of the notching machine can lead to serious injuries.

- Before restarting, ensure that the cause of the emergency stop has been eliminated and that all safety devices have been fitted and are fully functional.
- Only unlock the emergency stop button when there is no longer any danger.

3 Intended Use

The notching machine is designed exclusively for notching steel or stainless steel sheets. Notching is done with a fixed angle (90°). The machine is intended and suitable for commercial use. The machine must not be used in explosive environments.

The proper use also includes observing all indications in these operating instructions. Any use beyond the proper use or any other use is regarded as misuse.

For structural and technical changes to the notching machine the company Stürmer Maschinen GmbH assumes no liability. Claims of any kind due to damage due to improper use are excluded.

3.1 Improper use



WARNING!

Danger in case of misuse!

Misuse of the notching machine can lead to dangerous situations.

- Only operate the notching machine in the power range listed in the technical data.
- Never bypass or override the safety devices.
- Only operate the notching machine in a technically perfect condition.

The notching machine must not be used for notching materials made of light metals (e.g. aluminium or similar).

3.2 Residual risks

Even if all safety instructions are observed, and the machine is put to its intended use, there are still residual risks, which are listed below:

- Risk of injury of upper limbs while equipment is operating.
- Danger from the falling workpieces.

4 Technical Data

4.1 Table

Technical Data	AKM 130-3 P
Dimensions (LxWxH) max.	1020x660x1260 mm
Weight	160 kg
Max. cutting pressure	2,2 t
Cutting area length	130 mm
Cutting area width	130 mm
Table length	600 mm
Table width	460 mm
Table height	945 mm
Cutting capacity 90° (material with tensile strength 400 N/mm ²)	3 mm
Cutting capacity 90° (material with tensile strength 600 N/mm ²)	1,5 mm (only with optional knife set)
Notching angle	90°
Strokes/min	50
Stroke adjustment	3 mm
Working pressure	7 bar
Sound pressure level 1 m Distance	68 dB

Technical Data	AKM 150-2 P
Dimensions (LxWxH) max.	860x800x1260 mm
Weight	170 kg
Max. cutting pressure	2,2 t
Cutting area length	154 mm
Cutting area width	154 mm
Table length	600 mm
Table width	460 mm
Table height	945 mm
Cutting capacity 90° (material with tensile strength 400 N/mm ²)	2 mm
Cutting capacity 90° (material with tensile strength 600 N/mm ²)	1 mm (only with optional knife set)
Notching angle	90°
Strokes/min	40
Stroke adjustment	2 mm
Working pressure	7 bar
Sound pressure level 1 m Distance	68 dB



CAUTION!

In case of daily and continuous exposure to such high noise levels, the user is recommended to wear suitable protective equipment.

4.2 Type plate

Pneumatische Ausklinkmaschine pneumatic notching machine		CE	
Typ Type	AKM 130-3 P	Serien-Nr. Serial no.	<input type="text"/>
Artikel-Nr. Item no.	3833130	Baujahr Year of manufacture	<input type="text"/>
Max. Druckluftanschluss Max. compressed air supply	7 bar	Max. Schnittdruck Max. cutting pressure	2,2 t
		Stürmer Maschinen GmbH Dr.-Robert-Pfleger-Str. 26, 96103 Hallstadt Deutschland / Germany	

Pneumatische Ausklinkmaschine pneumatic notching machine		CE	
Typ Type	AKM 150-2 P	Serien-Nr. Serial no.	<input type="text"/>
Artikel-Nr. Item no.	3832150	Baujahr Year of manufacture	<input type="text"/>
Max. Druckluftanschluss Max. compressed air supply	7 bar	Max. Schnittdruck Max. cutting pressure	2,2 t
		Stürmer Maschinen GmbH Dr.-Robert-Pfleger-Str. 26, 96103 Hallstadt Deutschland / Germany	

Fig. 3: Type plates AKM 130-3 P and AKM 150-2 P

5 Transport, packaging, storage

5.1 Delivery and transport

Delivery

Check the notching machine on delivery for any visible transportation damage. If you notice any damage to the device please report this immediately to the carrier or dealer.

Transport



NOTE!

Oil may leak during transport of the notching machine. Secure the machine accordingly and take precautions against possible environmental pollution.

The notching machine may only be transported standing up and with the motor switched off.



NOTE!

The notching machine should be protected from humidity.

Transport with a forklift/lift truck:

For shipping, the notching machine is firmly mounted on a pallet so that it can be transported with a forklift truck or a lift truck.

Always use a forklift truck with the appropriate characteristics for lifting the packaging, taking into account the weight and dimensions:

- Adjust the forks so that the crate is properly balanced (Fig. 4).
- Place the crate on the floor.
- Remove the packaging from the machine.

Transport with a crane:



WARNING!

Danger to life due to falling load!

If the weight of the notching machine and the permissible load capacity of the lifting equipment are not observed during transport or lifting work, the machine may tilt or fall.

- Transport with a crane may only be carried out by specialists!
- When transporting and lifting, observe the weight of the notching machine and also the permissible load capacity of the lifting equipment.
- Use the intended attachment points for transport.
- The notching machine must not be rocked.

A transport eyebolt can be attached to the upper side of the notching machine housing in which the transport rope can be inserted (Fig.4).

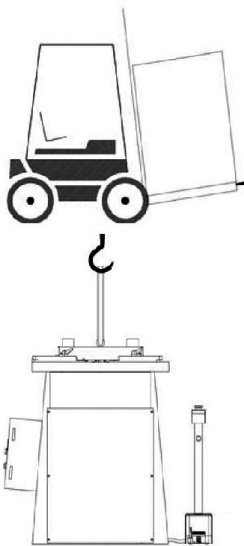

Fig. 4: Transport

- Remove the screws that secure the machine to the pallet.
- Remove the scrap container located on the machine worktable to prevent it from falling to the floor while moving. The container must be positioned on the left side of the machine.

The machine loading and unloading should always and only occur through a rope hooked up to the hoisting eyebolt placed on the upper side of the machine.



WARNING!

Never move the machine by hand or by any other means of transport not specified to avoid injury to persons or damage to the machine.

5.2 Packaging

All used packaging materials and packaging aids are recyclable and should be taken to a materials recycling depot to be disposed of.

The delivery packaging is made of cardboard, so please dispose carefully by having it chopped up and given to the recycling collection.

The film is made of polyethylene (PE) and the cushioned parts of polystyrene (PS). Deliver these substances to a collection point for recyclable materials or to the waste disposal company which looks after your region.

5.3 Storage

Store the notching machine thoroughly cleaned in a dry, clean and frost-free environment.

Apply protective oil to the upper and lower tools to prevent rusting.

Protect the machine from sunlight.

Keep the machine packed in a suitable place, e.g. protected and not exposed to bad weather. If the machine is to be taken out of operation for a short period of time, clean it thoroughly and cover it with a cloth.

6 Description of device

6.1 Representation

Illustrations in these operating instructions are for basic understanding only and may differ from the actual version.

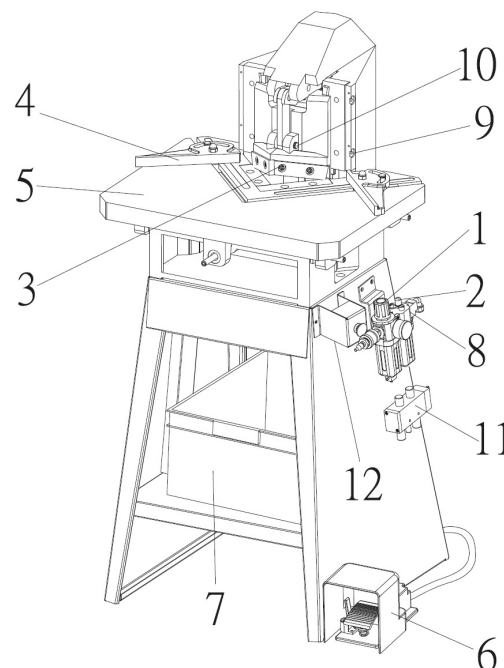

Fig. 5: Description of device AKM 130-3 P, AKM150-2 P

- 1 Pressure regulator valve
- 2 Air pressure gauge
- 3 Punching tool
- 4 Adjustable fence
- 5 Table
- 6 Foot control pedal
- 7 Scrap Collecting Box (NOT INCLUDED)
- 8 Air control unit
- 9 Safety cover
- 10 Head set
- 11 Multi-purpose valve
- 12 Emergency stop switch

6.2 Scope of delivery

- Pneumatic Notching Machine
- Foot pedal
- 2 adjustable angle stops
- Internal stop
- Operating instructions

6.3 Accessories

- Top knife set for steel

7 Installation

7.1 Requirements for the location



ATTENTION!

Check the load-bearing capacity of the ground before you install the machine. The installation place must be capable of bearing the weight of the machine and the workpieces.

In order to ensure good functioning of the notching machine and a long service life, the installation site should meet the following criteria.

- The notching machine may only be installed and operated in dry, frost-free, well-ventilated rooms.
- Avoid places near machines that cause chips or dust.
- The place of installation must be vibration-free, i.e. away from presses, planing machines, etc.
- The substrate must be suitable for the work. Pay attention to the load-bearing capacity and evenness of the substrate.
- If necessary, protruding parts, such as support tables, etc., must be secured by on-site measures so that persons are not endangered.
- There must be enough space for the operating personnel, for the transport

- of material as well as for adjusting and maintenance.
- Also consider the accessibility for adjustment and maintenance.
- The working area must have the sufficient lighting (minimum value: 300 lux).
- The air humidity should be in the range of 10% to 90% and the measured room temperature should be between 0°C - 50°C max.

Setting up the machine:

Step 1: Make sure that the space around the machine is sufficient for the application (Fig. 6). There must be sufficient space for the operator and material transport.

Step 2: Check each part of the machine for proper condition before starting to set it up.

Step 3: Place the control foot pedal in the best position for the application in front of the work area.

Ensure that there is an area around the machine in all four directions at a distance of $X = 1000$ mm from the working area (Fig. 6).

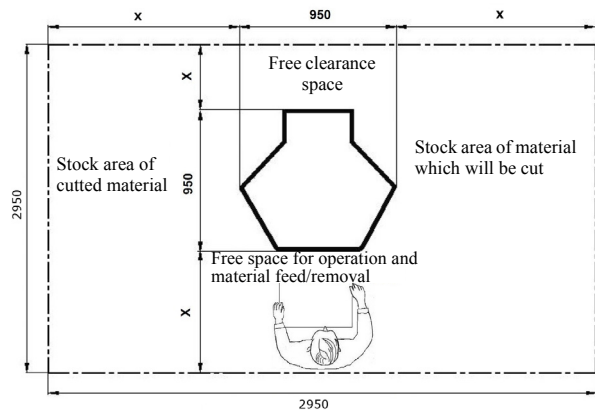

Fig. 6: Installation plan



ATTENTION!

The machine is delivered unfilled. Before commissioning, hydraulic oil must be filled into the tank. Only use suitable hydraulic oil for refilling.

7.2 Unpacking and setting up

The machine is packed with wooden crate box and seal with plastic bag.

Step 1: Please check the it has any damage or not before operation.



NOTE!

On the upper side of the notching machine housing, a transport eyebolt can be fitted into which the transport rope for crane transport can be inserted (Fig. 4).

Step 2: Remove the screws (Fig. 7) that secure the machine to the pallet.

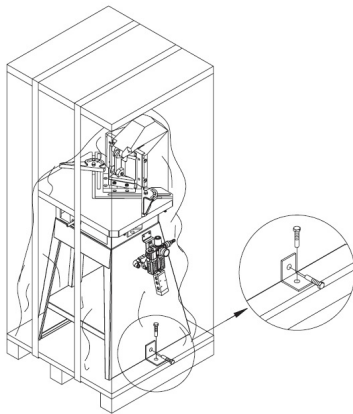

Fig. 7: Unscrew the pallet from the transport

Step 3: Remove the scrap container located on the machine worktable to prevent it from falling to the floor while moving. The container must be positioned on the left side of the machine.

Step 4: The machine may only be loaded and unloaded using a rope for attachment to a crane. This rope must be attached to the eyebolt, which must be placed on top of the machine.

Step 5: Use a crane to lift the machine from the pallet and move it to the working position (Fig. 10).

Step 6: Ensure the correct position of the forks when attaching (Fig. 8) when transporting with a forklift truck. The forks must be placed under the table with the largest possible bearing surface. The table must be balanced before lifting.



WARNING!

Danger to life!

When lifting the machine with the forklift, the forks must be properly balanced to prevent the machine from falling down.

Never lift the machine by placing the forks on the edges of the worktable or in the lower part of the base frame.



WARNING!

Danger to life!

If the weight of the notching machine and the maximum load capacity of the lifting equipment are not observed during transport or lifting, the notching machine may tip or fall.

- When transporting and lifting, observe the weight of the notching machine and the permissible load capacity of the lifting equipment.

Check that the hoists and load slings are in perfect condition.

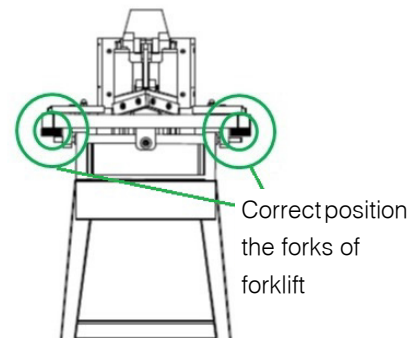
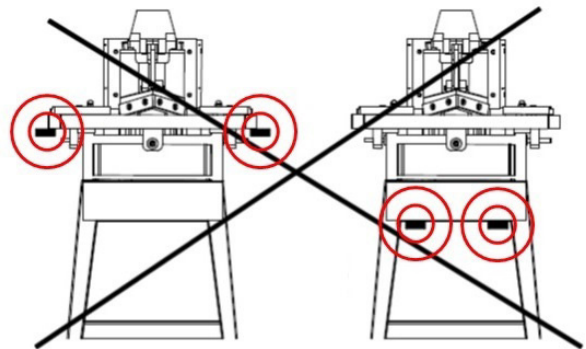

Fig. 8: Correct position of forklift for lifting



NOTE!

After installation, remove the grease from the blank metal parts which has been applied for protection.

- Use common solvent for this purpose, e.g. petroleum.
- Do not use water, nitro solvents, etc.!

After the machine has been thoroughly cleaned, all blank parts must be lightly oiled. Only use resin- and acid-free machine oil!



Tips and recommendations

For a safe stand, it is recommended that the machine is fastened to a firm, stable and level surface using the holes provided in the machine base.

7.3 Electrical connection



ATTENTION!

Never operate the foot pedal when:

- The electrical supply or air pressure supply is not yet connected.
- Carry out maintenance.

7.4 Connecting the compressed air

After connecting the compressed air to the local supply, check that there are no leaks in the air circuit at hoses 2 and connectors 1 (Fig.9).

The compressed air unit is preset to 6 bar working pressure.

If it is necessary to adjust the air pressure, proceed as follows:

- Turn the adjusting handle of the pressure regulator (Pos. 3, Fig. 9) of the compressed air supply unit until the required pressure is set. Check the set pressure on the pressure gauge (Pos. 4, Fig. 9).



ATTENTION!

The compressed air to the machine must be free of dirt and have a low air humidity to prevent damage to the machine and cylinder!

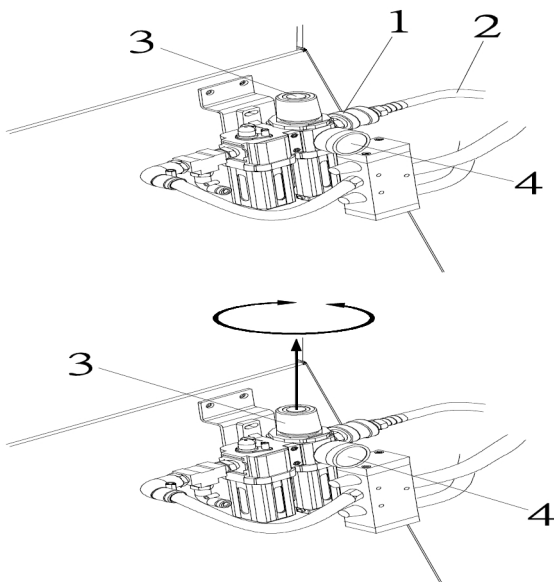

Fig. 9: Compressed air unit

8 Settings



DANGER!

Incorrect mechanical settings can change the safety of the machine in such a way that it poses a permanent danger. Negligent behaviour can endanger both the personnel and the machine when it is switched on again.

- Before making any mechanical adjustments, always switch off the machine at the main switch and secure the main switch against unintentional re-starting, e.g. by attaching a warning sign.
- After carrying out the adjustment works, make sure that all covers and guards have been properly installed on to the machine.
- Do not leave any tools unintentionally inserted during adjustment activities. Before switching on the machine again, make sure that all setting tools have actually been removed. Make sure that no tools are left inside the machine, especially in the working area of the machine mechanics.



ATTENTION!

Settings on mechanically acting machine elements may only be carried out on the machine by trained specialists or specially trained and instructed persons.

8.1 Setting of the cutting gap

Setting of the cutting gap is carried out after initial commissioning and after each knife change.



ATTENTION!

There is a risk that the machine will be damaged if the cutting gap is set incorrectly.



Use protective gloves!

The machine is pre-adjusted for cutting 3 mm thick material with a tensile strength of 42 kg/mm² and a gap knife tolerance of 0.3 mm.

- If the cutting gap is set too large, burrs and chips may form during the notching process. If the cutting gap is set too small, the knives may be damaged and the stroke may block.
- After adjusting the cutting gap, make a few test cuts.
- It is necessary to change the equipment if the notching metal sheet is thinner than 2 mm (R=70 kg/mm²).

Setting of the cutting gap

Step 1: Lower the release head by holding down the foot pedal.

Step 2: Pull the handle E located on the air supply unit (Fig. 10).

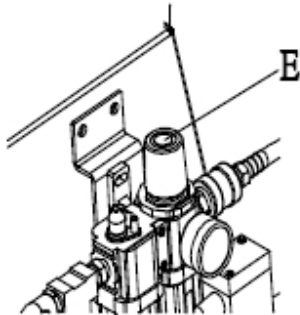

Fig. 10: Rotary handle on pressure regulating valve

Step 3: Leave the compressed air to drain completely.

Step 4: Release the pedal.

Step 5: Disconnect the air supply hose.

Step 6: Remove the safety cover 1 by unscrewing the screws (Pos. 2, Fig. 11).

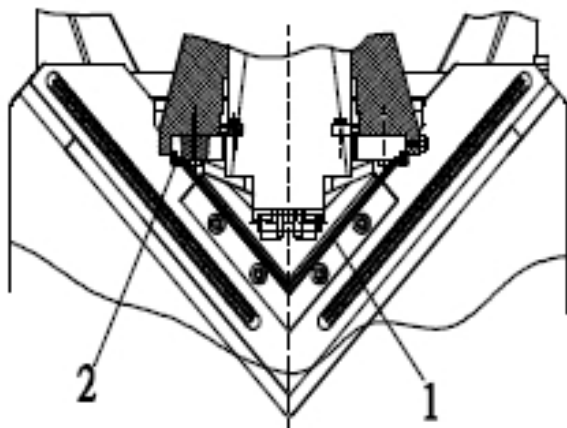

Fig. 11: Remove the safety cover

Step 7: Remove screw (Pos. 3, Fig.12).

Step 8: Increase or decrease the cutting gap using the adjusting screw in areas (Pos. 4 and 5, Fig. 12).

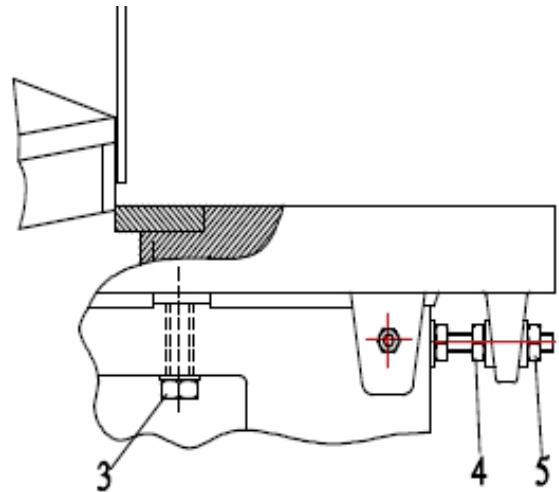

Fig. 12: Adjusting the cutting gap

Step 9: When adjusting the cutting gap, consider the following values (Fig. 13):

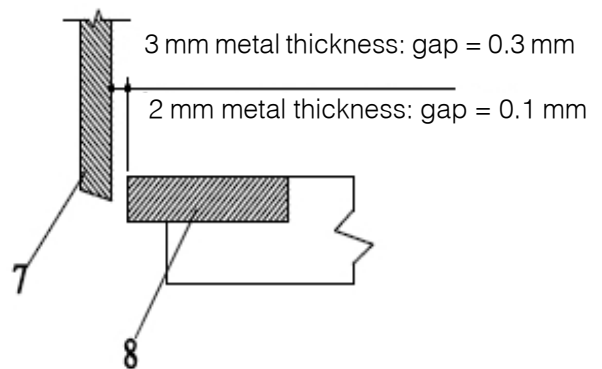

Fig. 13: Ratio of material thickness and cutting gap

Step 10: Use the thickness gauge to adjust the cutting gap (Fig. 14).

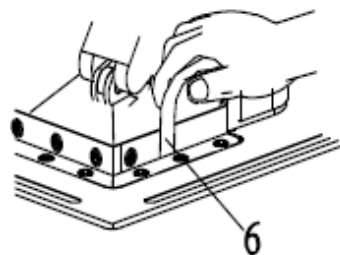

Fig. 14: Cutting gap detection via the thickness gauge

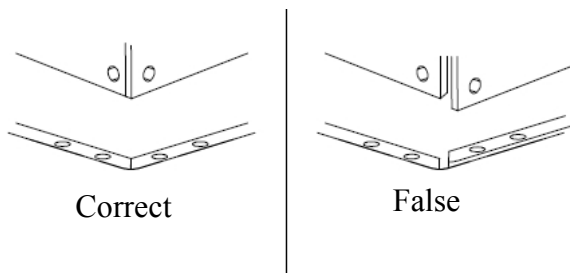

Fig. 15: Correct knife position

8.2 Replace of the knife

Replace the knives in time. Blunt knives lead to poorer cutting performance.



Use protective gloves!



CAUTION!

Only use the recommended original spare knives. There is a risk that poorer material properties will lead to knife breakage and cause injury and damage to the machine.

- Poor knife quality reduces the service life of the knives.
- There is a danger that after a knife change the cutting gap will be set incorrectly and the machine will be damaged.
- Use protective gloves when changing the knives.
- After each knife change, make sure that the cutting gap is within the permissible setting range.
- Readjust the cutting gap.

Replacing the upper knives

Step 1: Move the knife bar to the upper end position, adjust the knife angle to 30° and switch off the machine. Now secure the machine against accidental restarting.

Step 2: Remove the protective cover from the movable cutter bar as follows:

- Remove the retaining screws.
- Lift the protective cover off the cutter bar and keep it in a safe place.

Step 3: Replace both upper knives as follows:

- Loosen three of the four fastening screws.
- Then unscrew the middle fixing screw and carefully remove the knife.
- To remove the second upper knife, proceed as described in steps 1 and 2.

- When installing, screw in the middle fixing screw first and then the other screws.
- When tightening all screws, make sure that there is no gap at the abutting points of the knives.
- Now replace the lower knives and then check the cutting gap. If necessary, readjust it immediately.

Step 4: If no further work is to be carried out in the knife area, place the protective cover back on the

Replacing the lower knives

Step 1: Move the knife bar to the upper end position, adjust the knife angle to 140° and switch off the machine by actuating the main switch. Now secure the main switch against being accidentally switched on again.

Step 2: Remove the protective cover from the movable knife bar as described in chapter „Replacing the upper knives“.

Step 3: Replace the two lower knives as follows:

- Unscrew the guide bearing.
- Unscrew the fixing screws in each case.
- Remove the knives.
- Unscrew the two adjusting screws from each knife and screw them into the new knives.
- Insert the new knives into the knife holders in the correct position so that the fastening screws can be easily screwed into the fastening threads.
- When tightening all screws, make sure that there is no gap at the abutting points of the knives.
- **Now** - as the upper knives should already have been replaced - check the cutting gap and adjust it immediately if necessary.

Step 4: If no further work is to be carried out in the knife area, place the protective cover back on the guide columns of the movable knife bar and screw it tight.

8.3 Cutter bar-Stroke limit

The stroke limitation of the movable cutter bar is set by an upper or lower limit switch. Both limit switches are actuated mechanically by adjustable switching cams. The setting of the switching cams is carried out in the factory. The setting must not be changed.



ATTENTION!

There is a risk that the machine will be damaged if the knife bar stroke is set incorrectly.

- Never change the factory setting of the switching cams!
- Improper adjustment of the switching cams may invalidate the warranty claim.
- Repairs to the knife bar stroke limiter, e.g. the replacement of defective parts, may only be carried out by skilled personnel with experience in setting limit switches!

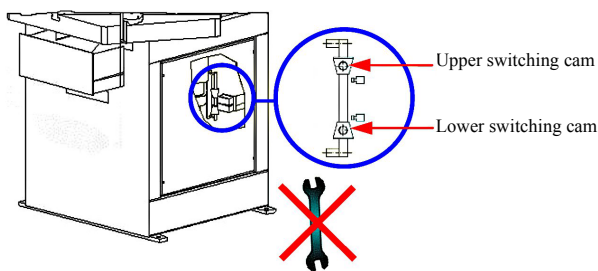

Fig. 16: Stroke limiting

8.4 Setting the limit stops

Step 1: Move the knife bar to the upper end position and switch off the machine by actuating the main switch. Now secure the main switch against being accidentally switched on again.

Step 2: Set the currently required stops according to the following information.

Adjustable stops are used to limit or guide the processing of the sheets.

Adjustment elements/accessories (Fig. 17):

A Angle display

B Hexagon socket wrench 5 mm

C 0,3 mm thickness gauge

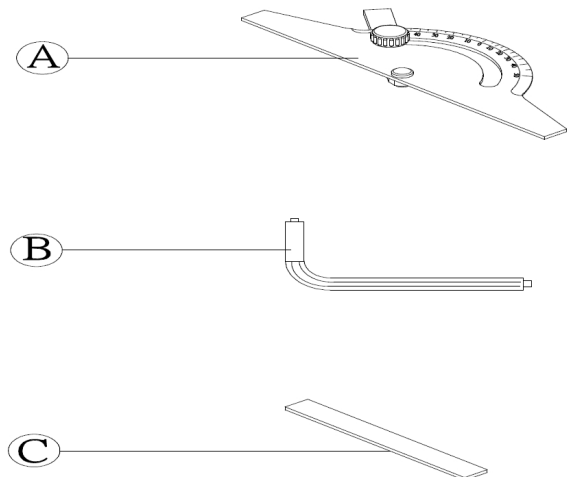

Fig. 17: Adjustment elements

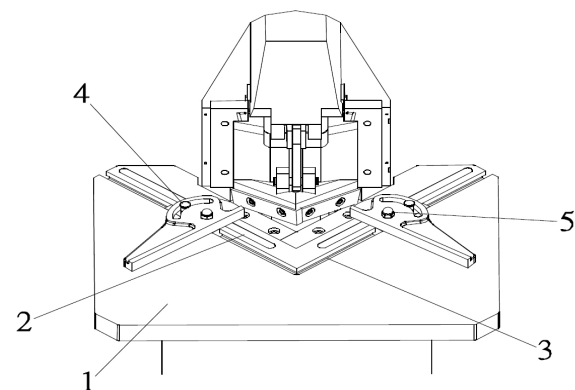

Fig. 18: Scales

1 Work table

2 Scale

3 T-slot

4 Slot hole for angle adjustment

5 Limit stop

Step 3: Place the punching material on the worktable.

Step 4: Adjust the stops over the angle scales and the diagonal scales according to the workpiece dimensions.

Step 5: Fix the left and right workpiece stops by tightening the screws over the nuts.

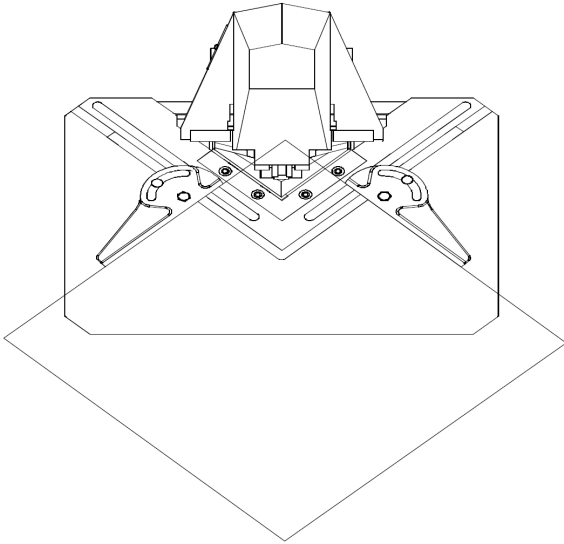

Fig. 19: Scales

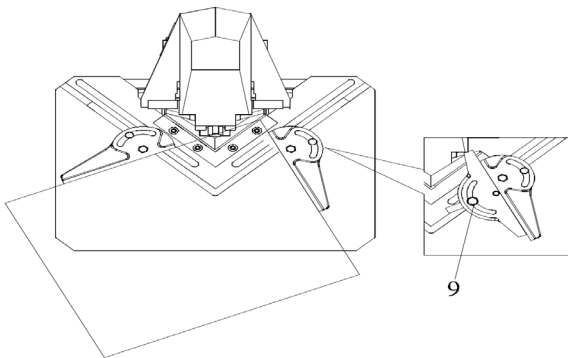

Fig. 20: Scales

9 Operation



WARNING!

Danger to life!

Failure to observe the following rules entails a risk of fatal injury for the operator and other persons.

- The operator must not work under the influence of drugs, alcohol or medication.
- The operator must not work in case of tiredness or if suffering from an illness that impairs concentration.
- The notching machine must be operated by one person only. Additional persons must keep out of the work area during operation



DANGER!

Risk of injury!

When working on the notching machine

- wear close-fitting clothing.
- do not wear jewellery.
- do not wear scarves, ties or similar.
- tie back long hair with hair net.



ATTENTION!

- Never change the settings for the hydraulic system. This is especially true for valves present there.
- Never change the setting of the cutter bar stroke limit.
- Only operate the machine from the front.
- Ensure that the workpieces are fixed when working. Use the stops for this purpose.
- Adjust the stops only when the machine is switched off (main switch in the position "OFF").
- When setting the stops, observe the minimum and maximum cutting length.
- When adjusting the inner stop, make sure that no collision with the upper knives can occur.
- When cutting metal strips to length, make sure that the cutting line is not longer than the knife length.
- Always place the metal sheets over their entire surface on the worktable. If necessary, support laterally protruding material with stable and stable material stands.



Wear hearing protection!



Use protective goggles!



Use protective gloves!



Wear safety boots!



Wear protective clothes!

9.1 Initial operation

Before initial operation, make sure that the following points are fulfilled:

- The machine is anchored to the ground at the place of installation, safety regulations (BetrSichV) have been implemented
- Any defects have been eliminated,
- Upper and lower knives cannot (accidentally) collide.

Make yourself familiar with all switching functions as described in chapter 7. Do not omit any switching function to ensure that you can operate all electrical controls correctly during subsequent operation:

- Make sure that all guards are fitted. The side maintenance protection covers must be firmly screwed to the machine.
- Check that the foot pedal is connected and can be operated with the foot in front of the machine.
- Now switch on the machine.
- Test all functions of the controls. Note that some functions are only available if another function is switched on at the same time.
- If possible, check the emergency stop function now. If everything is working correctly, switch off the machine again afterwards.



ATTENTION!

The machine is delivered unfilled. Before commissioning, hydraulic oil must be filled into the tank. Only use suitable hydraulic oil for refilling.

9.2 Workflow



Tips and recommendations

Before starting production, make a few test cuts!

Step 1: Connect the notching machine to compressed air.

Step 2: Check all fuses in the control box.

Step 3: Adjust the cutting gap.

Step 4: Adjust the angle stops to the notch dimension.

Step 5: Place the workpiece on the work surface and place it against the stops.

Step 6: Press the pedal for the cut depending on the setting.

Step 7: Remove the workpiece.

Press the EMERGENCY STOP button in emergencies. The movement of the top beam stops and the top beam automatically returns to its highest position.

9.3 Switching off the machine

Step 1: Switch off the machine and disconnect it from the compressed air supply.

10 Care, maintenance and repair



Tips and recommendations

In order that the device is always in good operating status, it is necessary to regularly perform care and maintenance works.



WARNING! Danger from the insufficient qualification of persons!

Insufficiently qualified persons cannot assess the risks involved in repair work on the notching machine and expose themselves and others to the risk of serious injury.

Have all maintenance work carried out by qualified personnel only.



DANGER!

When carrying out maintenance and repair work, make sure that the compressed air supply hose is disconnected from the supply and that the MAIN switch is set to OFF.



NOTE!

After cleaning, maintenance and repairs, make sure that all panels and protective guards are once again correctly in place on the machine and that there are no tools on the inside or outside of the machine.

Damaged protective guards and machine parts must be professionally repaired by an approved workshop, or replaced.



ATTENTION!

When carrying out inspections and maintenance tasks, pay attention to protruding parts of the machine in order to avoid injuries due to impacts!

10.1 Cleaning and lubricating the machine



ATTENTION!

- Before starting cleaning and lubrication, switch off the machine and disconnect the mains plug!
- Never use solvents to clean plastic parts or painted surfaces. Loosening of the surface and resulting consequential damage can occur.
- Never use a water jet for cleaning.

The notching machine should always be cleaned after each use.

Sweep or wipe all open machine parts with a broom or cloth at regular intervals.

Treat bare metallic work surfaces with anti-rust spray.

Lubricate all moving parts and bearings monthly.

Step 1: Fill oil lubrication holes (Pos. A, Fig. 21) and lubricate connector (Pos. B, Fig. 21). Do this daily to ensure smooth running of the machine.

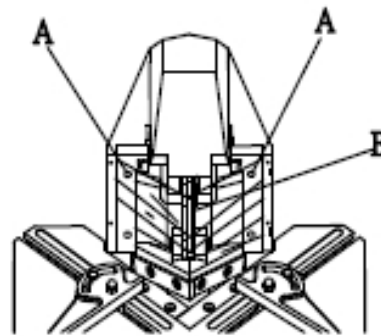

Fig. 21: Lubricating points

Step 2: Check the oil level in lubrication system (Pos. 1, Fig. 22) and top up with high viscosity oil.

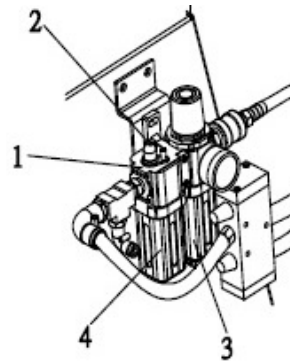

Fig. 22: Filter change and lubrication

Step 3: Add lubricant to lubricator 1 as follows:

- Release the air and disconnect the supply hose by pulling off the coupling.
- Press the safety switch and turn container (Pos. 4 Fig.22) counterclockwise.
- Fill it up and restore it to its original condition.

Regularly check the oil flow in the lubricator (Pos. 1, Fig. 22). One drop must fall after each fifth cycle.

In case of incorrect lubrication, please proceed as follows and adjust the lubrication if necessary:

- Turn the screw (Pos. 2, Fig. 22) on the lubricator clockwise to reduce the oil flow.
- Turn the screw (Pos. 2, Fig. 22) counterclockwise to increase the oil flow.



ATTENTION!

Supply the recyclable materials to the appropriate disposal channels.

10.2 Maintenance of the machine



ATTENTION!

- Maintenance and repair work may only be carried out by qualified personnel.
- Only use original spare parts.
- All protective and safety devices must be reinstalled immediately after completion of repair and maintenance work.
- Before starting cleaning and lubrication, always switch off the machine at the MAIN switch and disconnect it from the compressed air connection!

Check filter (Pos. 3, Fig. 22) regularly for condensate accumulation. Condensate accumulation can endanger the machine application.

Change the oil filter once a month.



ATTENTION!

Never step on the foot pedal when:

- You have connected the electrical supply and the air pressure supply.
- You want to start the application during operation.
- You have completed a started maintenance.

If the notching machine does not function properly, contact a specialist dealer or our customer service. The contact details can be found in chapter 1.2 Customer service.

11 Disposal, recycling of used device

Please take care in your own interest and in the interest of the environment that all component parts of the machine are only disposed of in the intended and permitted way.

11.1 Decommissioning

Immediately decommission disused machines in order to avoid later misuse and endangering of the environment or personal safety.

- Eliminate all environmentally hazardous operating materials from the used device.
- If required, disassemble the machine into easy-to-handle and usable components and parts.
- Dispose of machine components and operating materials by the disposal channels provided.

11.2 Waste disposal of electric equipment

Please note that electrical devices contain a variety of recyclable materials as well as environmentally harmful components.

You contribute to that these components are disposed of separately and properly. In case of doubt, please contact your municipal waste disposal. As necessary, a specialized waste disposal company can help be used for the treatment.

11.3 Disposal of lubricants

Please pay attention to an environmentally friendly disposal of the used coolants and lubricants.

Observe the disposal instructions of your municipal disposal companies.

Disposal notes for used lubricants are available from the manufacturer of the lubricants. If necessary, request the product-specific data sheets.

12 Disturbances, possible causes and measures



ATTENTION!

If one of the following errors occurs, immediately stop working with the notching machine. Before you begin troubleshooting, turn off the notching machine and unplug the power card. Otherwise it could lead to serious injuries. All repairs or replacement work may only be carried out by qualified and trained specialist personnel.



NOTE!

You cannot solve the problems with the notching machine yourself, then please contact your nearest CLEANCRAFT dealer. Please write down the following information from the notching machine or the operating instructions in advance to help you solve your problem in the best possible way.

- Model name of the device
- Serial number of the device
- Construction year/Exact error description

Malfunction	Possible cause	Solution
Control elements on the control panel are functionless.	1. Emergency stop button has been actuated.	1. Unlock the emergency stop button.
Upper knife does not react to a button actuations in the hand mode.	1. Selector switch for manual/foot operation on the control panel is defect.	1. Have it checked by a qualified technician.
Upper knife does not react to pedal actuations in pedal mode.	1. Limit switch for upper/lower limit is defect	1. Have it checked by a qualified technician.
Upper knife does not react	1. Relief pressure valve is dirty or defect. 2. The oil level is not correct. 3. Oil filter is blocked.	1. Have checked and repaired by a qualified hydraulic technician. 2. Have checked and filled by a hydraulic specialist. 3. Check, clean or have changed by a qualified hydraulic technician.

13 Spare parts

13.1 Spare parts ordering



NOTE!

The manufacturer's warranty will become null and void if non-permissible spare parts are used.



DANGER!

Danger of injury by the use of wrong spare parts!

Dangers may result for the user and damages as well as malfunctions may be caused by using wrong or damaged spare parts

- Only use original spare parts of the manufacturer or spare parts admitted by the manufacturer.
- Always contact the manufacturer in case of uncertainties.

The spare parts may be purchased with the authorised dealer or directly with the manufacturer. Please find the corresponding contact data in Chapter 1.2 Customer service.

Indicate the following basic information for requests or orders of spare parts:

- Type of device
- Item No.
- Position No.
- Year of construction:
- Quantity
- Required mode of dispatch (mail, freight, sea, air, express)
- Address of dispatch

Spare part orders which do not include the above indications may not be taken into consideration. If the indications regarding the mode of dispatch are missing, the product is dispatched at the discretion of the supplier. You will find information regarding the device type, item No. and year of manufacture on the type plate fixed to the device.

Example

The foot pedal for the notching machine AKM 150-2 P must be ordered. The pedal is identified in the spare parts drawing with the number 65.

When ordering spare parts, send a copy of spare parts drawing with marked foot pedal component and marked position number 65 to the authorised dealer or to the spare parts department and provide the following information:

Type of device: **Pneumatic Notching Machine AKM 150-2 P**
 Item number: **3832150**
 Position number: **65**

13.2 Spare parts drawing

In case of the service, the following drawing shall help to identify the necessary spare parts. If necessary, send a copy of the parts drawing with the marked components to your dealer.

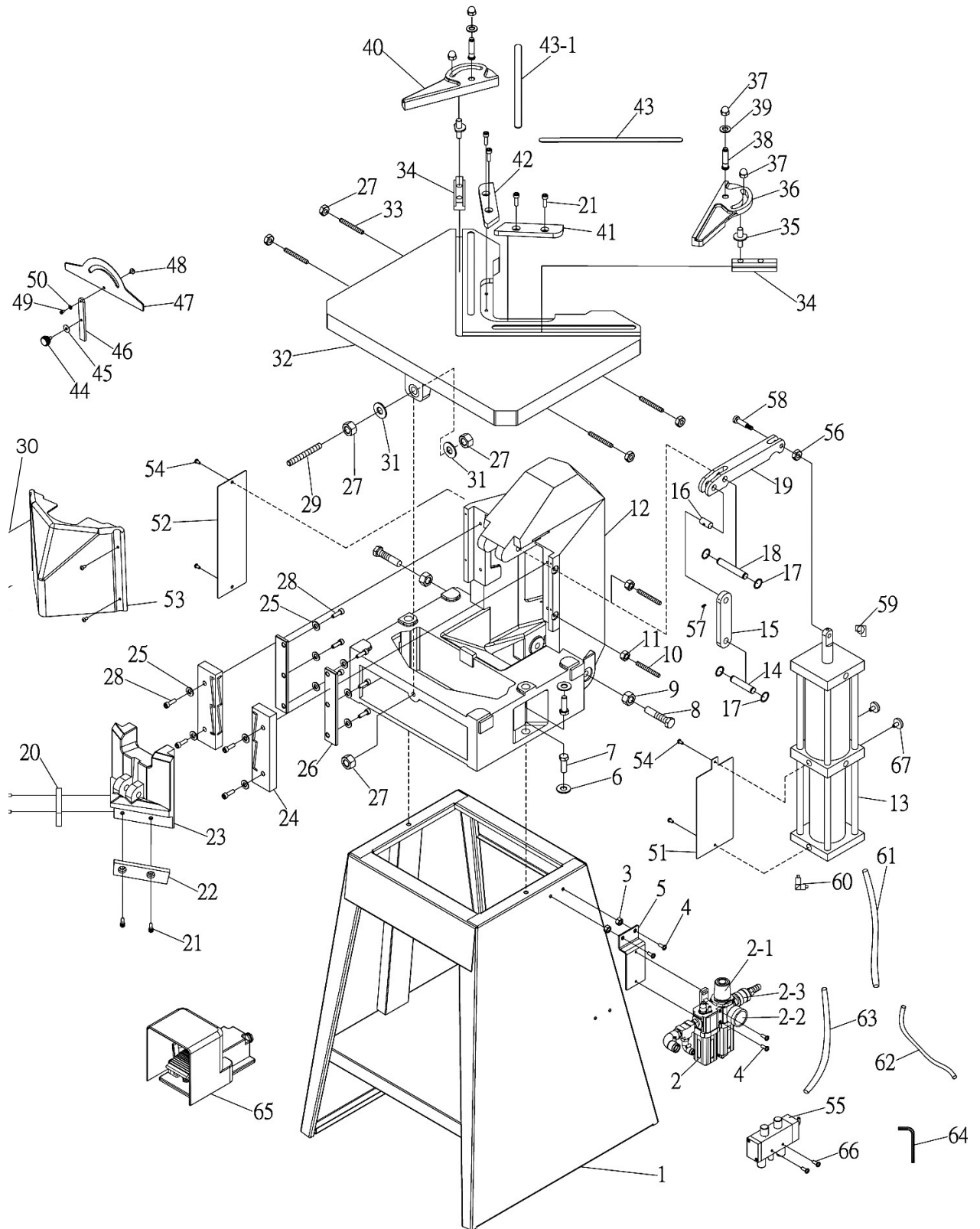

Fig. 23: Spare parts drawing

14 Pneumatic plan

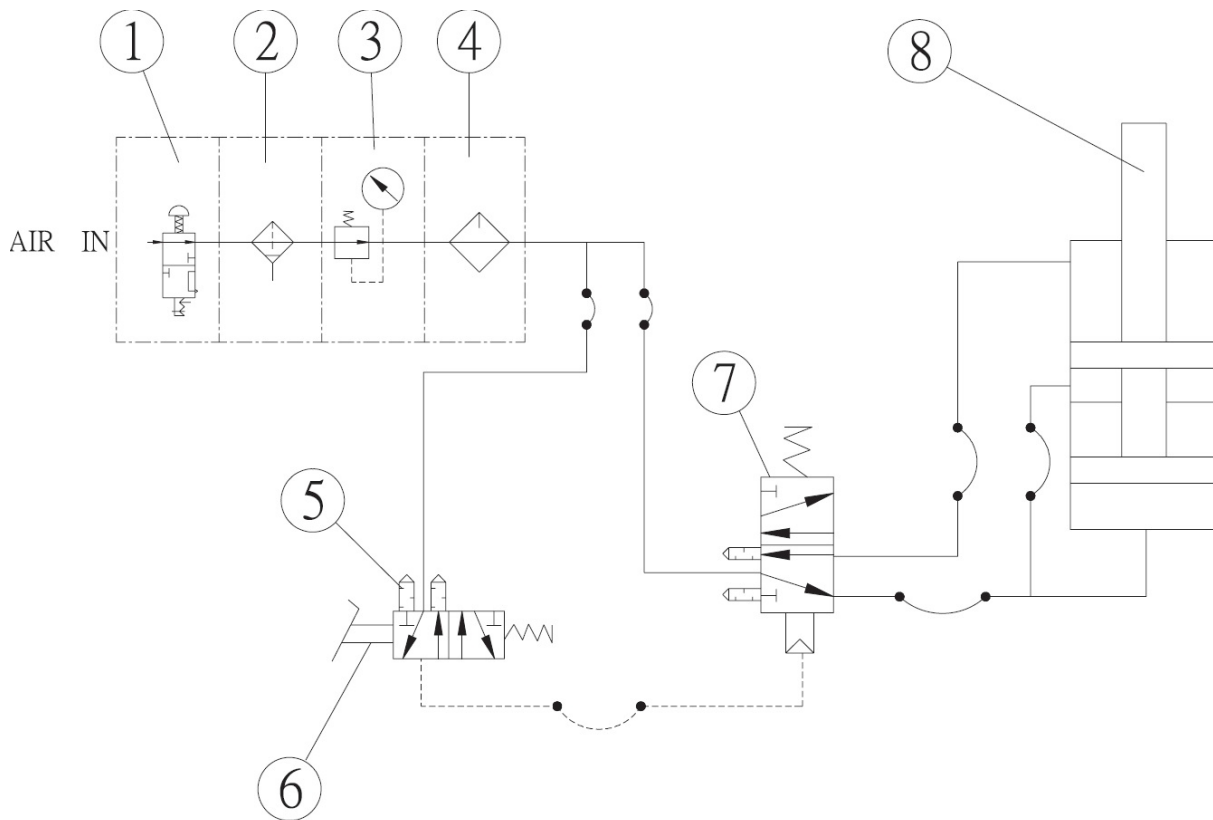

Fig. 24: Pneumatic plan

15 EC Declaration of Conformity

According to Machinery Directive 2006/42/EC, Annex II 1.A

Manufacturer / distributor: Stürmer Maschinen GmbH
Dr.-Robert-Pfleger-Str. 26
D-96103 Hallstadt

hereby declares that the following product

Product group: Metalkraft® Metal Working Machines

Machine type: Pneumatic Notching Machine

Designation of the machine: AKM 130-3 P
AKM 150-2 P

Item number: 3833130
3832150

Serial number: _____

Year of manufacture: 20____

complies with all relevant provisions of the above mentioned directive as well as the other applied directives (below) - including their applicable modifications at the time of the declaration.

Following harmonized norms were applied:

DIN EN ISO 12100:2010 Safety of machinery - General principles for design -
Risk assessment and risk reduction

DIN EN 60204-1:2014-10 Safety of machinery - Electrical equipment of machines -
Part 1: General requirements

Responsible for documentation: Kilian Stürmer, Stürmer Maschinen GmbH
Dr.-Robert-Pfleger-Str. 26, D-96103 Hallstadt

Hallstadt, 17.10.2017



Kilian Stürmer
CEO, Manager



