

Instruction Manual

— Plate rolling machines

- RBM 1050-30 E
- RBM 1270-25 E
- RBM 1550-20 E
- RBM 2050-15 E



RBM 1270-25 E

RBM E SERIES

Imprint

Product identification

Metallkraft

Plate rolling machine

Model	Item number
RBM 1050-30 E	3813201
RBM 1270-25 E	3813202
RBM 1550-20 E	3813203
RBM 2050-15 E	3813204

Manufacturer

Stürmer Maschinen GmbH
Dr.-Robert-Pfleger-Str. 26
D-96103 Hallstadt

Fax: 0049 (0) 951 96555 - 55

E-Mail: info@metallkraft.de
Internet: www.metallkraft.de

Indications regarding the operating instructions

Original instructions

Edition: 14.05.2019

Version: 1.07

Language: English

Author: ES/MS

Indications regarding the copyright

Copyright © 2019 Stürmer Maschinen GmbH, Hallstadt, Germany.

The contents of these operating instructions are the sole property of the company Stürmer.

Passing on as well as copying of this document, the use and distribution of its content are prohibited if not explicitly permitted. Contraventions are liable to compensation.

Subject to technical modifications and error.

Contents

1 Introduction	4
1.1 Copyright.....	4
1.2 Customer service	4
1.3 Limitation of liability.....	4
2 Safety.....	5
2.1 Symbol explanation.....	5
2.2 Responsibility of the operator	6
2.3 Requirements to staff.....	7
2.4 Personal protective equipment	7
2.5 General safety regulations	8
2.6 Safety labels on the machine.....	8
3 Intended Use	9
3.1 Misue	9
3.2 Residual risks.....	9
4 Technical Data	10
4.1 Type plate	10
5 Transport, packaging, storage	10
5.1 Delivery and transport.....	10
5.2 Packaging	11
5.3 Storage	12
6 Description of the machine	12
6.1 Specification and standard equipment.....	12
6.2 Optional equipment.....	13
6.3 Safety switch.....	13
7 Set up and connection	14
7.1 Set up.....	14
7.2 Danger zones.....	15
7.3 Assembly of the safety line	16
7.4 Lubricate bearings	16
7.5 Electrical connection	17
7.6 Direction of rotation of the motor.....	18
8 Commissioning	19
8.1 Operation	20
8.2 Bending operation.....	22
9 Maintenance and Cleaning	28
9.1 Cleaning and lubrication of the machine	28
9.2 Troubleshooting	30
10 Disposal, recycling of used devices.....	30
10.1 Decommissioning.....	30
10.2 Disposal of electrical equipment	30
10.3 Disposal of lubricants.....	30
11 Spare parts.....	31
11.1 Ordering spare parts	31
11.2 Spare parts drawing.....	32
12 Electrical-schematic	33
13 EC Declaration of Conformity	34
14 Notes	35

1 Introduction

You have made a good choice by purchasing the METALLKRAFT machine.

Read the operating manual thoroughly before commissioning the machine.

It gives you information about the proper commissioning, intended use and safe and efficient operation and maintenance of your machine.

The operating manual is part of the Machine package. Always keep this operating manual in the location where your Machine is being operated. All local accident prevention regulations and general safety instructions for the operating range of your Machine must also be complied with.

Illustrations in this operating manual serve the general understanding and may deviate from the actual design.

1.1 Copyright

The contents of these instructions are copyright. They may be used in conjunction with the operation of the machine. Any application beyond those described is not permitted without the written approval of Stürmer GmbH.

For the protection of our products, we shall register trademark, patent and design rights, as this is possible in individual cases. We strongly oppose any infringement of our intellectual property.

1.2 Customer service

Please contact your dealer if you have questions concerning your bending machine or if you need technical advice. They will help you with specialist information and expert advice.

Germany:

Stürmer Maschinen GmbH
Dr.-Robert-Pfleger-Str. 26
D-96103 Hallstadt

Repair service:

Fax: 0049 (0) 951 96555-111
E-Mail: service@stuermer-maschinen.de

Spare part orders:

Fax: 0049 (0) 951 96555-119
E-Mail: ersatzteile@stuermer-maschinen.de

We are always interested in valuable experience and knowledge gained from using the application-which then could be shared and be valuable to develop our products even further.

1.3 Limitation of liability

All information and notes in these operating instructions were summarised while taking applicable standards and rules, the state-of-the-art technology and our long-term knowledge and experiences into consideration.

In the following cases the manufacturer is not liable for damages:

- Non-observance of the operating instructions,
- Inappropriate use
- Use of untrained staff,
- Unauthorized modifications
- Technical changes,
- Use of not allowed spare parts.

The actual scope of delivery may deviate from the explanations and presentations described here in case of special models, when using additional ordering options or due to latest technical modifications.

The obligations agreed in the delivery contract, the general terms and conditions as well as the delivery conditions of the manufacturer and the legal regulations at the time of the conclusion of the contract are applicable.

2 Safety

This section provides an overview of all important safety packages for the protection of operating personnel as well as for safe and fault-free operation. Other task-based safety notes are included in the paragraphs of the individual phases of life.

2.1 Symbol explanation

Safety instructions

The safety notes in these operating instructions are high-lighted by symbols. The safety notes are introduced by signal words which express the concern of the risk.

DANGER!



This combination of symbol and signal words indicates an imminently dangerous situation which may lead to death or severe injury if not avoided.

WARNING!



This combination of symbol and signal words indicates a potentially dangerous situation which may lead to death or severe injury if not avoided.

CAUTION!



This combination of symbol and signal words indicates a potentially dangerous situation which may lead to slight or minor injury if not avoided.

ATTENTION!



This combination of symbol and signal words indicates a possibly dangerous situation which may lead to property and environmental damages if they are not avoided.

NOTE!

This combination of symbol and signal words indicates a potentially dangerous situation which may lead to material or environmental damage if not avoided.

Tips and recommendations**Tips and recommendations**

This symbol highlights useful tips and recommendations as well as information for an efficient and trouble-free operation.

It is necessary to observe the safety notes written in these operating instructions in order to reduce the risk of personal injuries and damages to property.

2.2 Responsibility of the operator**Operator**

The operator is the person who operates the machine for commercial or economic purposes himself or leaves it to a third party for use or application and bears legal product responsibility during the operation for the protection of the user, the personnel or third parties.

Operator obligations

If the machine is used in the commercial sector, the operator of the machine is subject to the legal obligations for occupational safety. For this reason, the safety instructions in this operating manual as well as the safety, accident prevention and environmental protection regulations applicable to the area of application of the machine must be observed. The following applies in particular:

- The operator must obtain information about the applicable occupational safety regulations and, in a risk assessment, must also determine additional hazards resulting from the special working conditions at the place of use of the machine. He must implement these in the form of operating instructions for the operation of the machine.
- The operator must check during the entire period of use of the machine whether the operating instructions he has prepared comply with the current state of the regulations and adjust them if necessary.
- The operator must clearly regulate and determine the responsibilities for installation, operation, troubleshooting, maintenance and cleaning.
- The operator must ensure that all persons handling the machine have read and understood this manual. In addition, he must train the staff at regular intervals and inform them about the dangers.
- The operator must provide the personnel with the necessary protective equipment and bind the wearing of the required protective equipment.

Furthermore, the operator is responsible for ensuring that the machine is always in perfect technical condition. Therefore, the following applies:

- The operator must ensure that the maintenance intervals described in this manual are observed.
- The operator must have all safety equipment regularly checked for functionality and completeness.

2.3 Requirements to staff

The different tasks described in this manual represent different requirements to the qualification of the persons entrusted with these tasks.



WARNING!

Danger in case of insufficient qualification of the staff!

Insufficiently qualified persons cannot estimate the risks while using the vacuum cleaner and expose themselves and others to the danger of severe or lethal injuries.

- Have all works only performed by qualified persons.
- Keep insufficiently qualified persons out of the working area.

Only persons reliable working procedures can be expected from, are allowed to perform all works. Persons the responsiveness of which is affected by e. g. drugs, alcohol or medication, are not allowed to work with the machine.

The qualifications of the personnel for the different tasks are mentioned below:

Operator

The operator is instructed by the operating company about the assigned tasks and possible risks in case of improper behaviour. Any tasks which need to be performed beyond the operation in the standard mode must only be performed by the operator if it is indicated in these instructions and if the operating company expressly commissioned the operator.

Electrically qualified person

Electrically qualified person is due to their professional training, knowledge and experience as well as knowledge of the relevant standards and regulations, in a position to carry out work on the electrical systems and to independently recognize and avoid possible dangers.

Qualified personnel

Due to their professional training, knowledge and experience as well as their knowledge of relevant regulations the specialist staff is able to perform the assigned tasks and to recognise and avoid any possible dangers themselves.

Manufacturer

Certain works may only be performed by specialist personnel of the manufacturer. Other personnel is not authorized to perform these works. Please contact our customer service for the execution of all arising work.

2.4 Personal protective equipment

The personal protective equipment serves to protect persons against impairments of safety and health while working. The staff member has to wear personal protective equipment while performing different tasks on and with the machine which are indicated in the individual paragraphs of these instructions.

The personal protective equipment is explained in the following paragraph:



Protective gloves

The protective gloves serve to protect the hands against sharp components as well as against friction, abrasions or deep injuries.

Safety boots
 Safety boots protect the feet from being crushed, falling parts and slipping over on slippery ground.

Protective clothes
 Protective clothes are made of a tightly fitted fabric without the protruding parts of low tear strength.

2.5 General safety regulations

Please note the following:

- Use the guards and secure them securely. Never work without protections and get them working.
- Keep the machine and its working environment always clean. Ensure adequate lighting.
- The machine may not be modified in its design and may not be used for purposes other than those foreseen by the manufacturer.
- Never work under the influence of concentration-disturbing illnesses, fatigue, drugs, alcohol or medicines.
- Keep children and people unfamiliar with the machine away from their work environment.
- Do not pull on the mains lead to pull the plug out of the socket. Protect the cable from heat, oil and sharp edges.
- Disruptions that affect safety are eliminated immediately.
- Protect the machine against moisture (danger of short circuit)
- Before using the machine, make sure that no parts are damaged. Damaged parts must be replaced immediately to avoid any danger.
- Do not overload the machine! You work better and safer in the specified performance range.
- Only use original spare parts and accessories to avoid possible dangers and accident risks.

2.6 Safety labels on the machine

Safety markings and instructions are attached to the bending machine (Fig. 1, 2), which must be observed and followed.

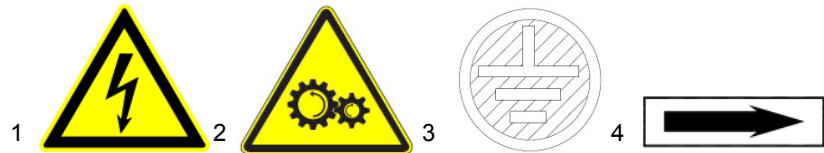

Fig. 1: Safety labels

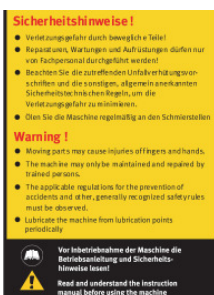

Fig. 2: Safety labels

The safety markings and instructions attached to the bender must not be removed. Damaged or missing safety markings can lead to malfunctions, personal injury and property damage. They are to be replaced immediately. If the safety markings and instructions are not immediately recognizable and comprehensible, the round bending machine must be taken out of operation until new safety markings have been made.

3 Intended Use

The RBM E plate rolling machine is used exclusively for the production of round shaped parts such as pipes, cones, cylinders, etc. The material to be bent must not exceed the maximum sheet thickness specified for the machine. The machine may only be operated by a single person who has been instructed in the use and maintenance of the machine.

Proper use also includes compliance with all information in this manual. Any use beyond the intended use or otherwise is considered misuse.

WARNING!



Dangers in case of unintended use!

Misuse of the machine can lead to dangerous situations.

- Only operate the bender in the power range specified in the technical data.
- Never bypass or override the safety devices.
- Only operate the round bending machine in a technically perfect condition.

Unauthorized modifications or alterations to the Bending Machine can invalidate the CE conformity of the Bending Machine and are prohibited. The company Stürmer Maschinen GmbH assumes no liability for design and technical changes to the bending machine.

The improper use of the bender and the disregard of the safety regulations or the operating instructions exclude liability of the manufacturer for resulting damage to persons or objects and cause the warranty to expire!

3.1 Misuse

If the intended use is observed, no reasonably foreseeable misuse is possible, which could lead to dangerous situations with personal injury.

3.2 Residual risks

Even if all safety regulations are observed and the machine is used correctly, there are still residual risks listed below:

- There is a risk of injury to the upper limbs (e.g., hands, fingers).
- Danger of falling workpieces
- During set-up and set-up work, it may be necessary to dismantle on-site protective devices. This creates various residual risks and potential dangers that every operator must be aware of.

4 Technical Data

	RBM 1050-30 E	RBM 1270-25 E	RBM 1550-20 E	RBM 2050-15 E
Bending width	1050 mm	1270 mm	1550 mm	2050 mm
Max. sheet thickness*	3 mm	2,5 mm	2 mm	1,5 mm
Roller Ø	90 mm	90 mm	90 mm	95 mm
Bending Ø min.	135 mm	135 mm	135 mm	145 mm
Motor output (400 V)	1,1 kW	1,1 kW	1,5 kW	1,5 kW
Roller Speed	6 m/min.	6 m/min.	6 m/min.	6 m/min.
Dimensions (LxBxH) [mm]	1630x700x1200	1850x700x1200	2130x700x1200	2630x700x1200
Weight	480 kg	520 kg	580 kg	715 kg
Noise level	< 70 dB(A)	< 70 dB(A)	< 70 dB(A)	< 70 dB(A)

*Performance data for material with tensile strength of 400 N/mm²; conical bending performance = factor 0.5; bending performance aluminium = 1.2; bending performance stain-less steel (VA) = factor 0.75; the optional tempered rollers are necessary for bending stainless steel (VA) ** Please turn over for descriptions of the packaging surcharges;

4.1 Type plate

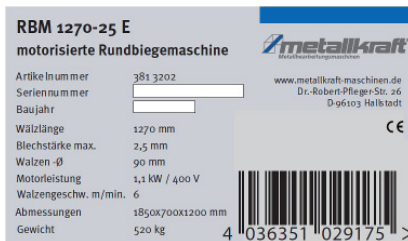

The type plate with the following data for identification as well as the CE marking are attached to the round bending machine (Fig. 3).

Fig. 3: Type plate

5 Transport, packaging, storage

5.1 Delivery and transport

Delivery

Check the machine on delivery for any visible transportation damage. If you notice any damage to the device please report this immediately to the carrier or dealer.

Transport

WARNING!



Danger to life!

If the weight of the machine and the permissible lifting capacity of the lifting equipment are not observed during transport or lifting, the machine may tip over or fall.

- Observe the weight of the machine and the permissible lifting capacity of the lifting equipment during transport and lifting operations.
- Check lifting gear and load handler for perfect condition.

The machine may only be loaded and unloaded by qualified personnel.

To avoid accidents, the necessary precautions must be taken when unloading and transporting the machine.

DANGER!



Before transporting, check that the upper roller lock is in the closed position and that the transport ropes are tightened.

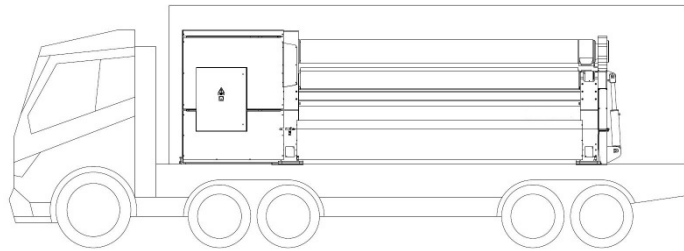
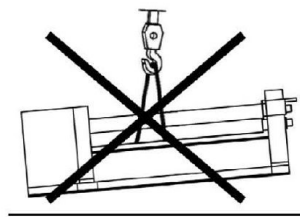
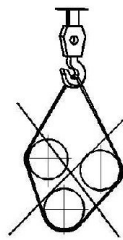
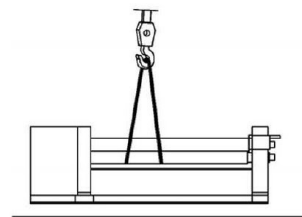
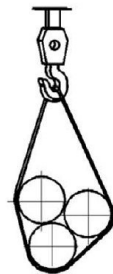

Fig. 4: Transport by LKW



Wrong



Right

Fig. 5: Transport by crane

5.2 Packaging

All used packaging materials and packaging aids are recyclable and should be taken to a materials recycling depot to be disposed of.

The delivery packaging is made of cardboard, so please dispose carefully by having it chopped up and given to the recycling collection.

The film is made of polyethylene (PE) and the cushioned parts of polystyrene (PS). Deliver these substances to a collection point for recyclable materials or to the waste disposal company which looks after your region.

5.3 Storage

The machine must be thoroughly cleaned before storing it in a dry, clean, dust- and frost-free environment. It must not be shut down with chemicals in a room. If the machine must be stored in a damp room, all electrical components in the control cabinet as well as the hydraulic system must be protected by moisture-absorbing agents. If the machine is stored for a long time, all bare metal parts must be greased against rusting.

6 Description of the machine

Illustrations in this operating manual serve the general understanding and may deviate from the actual design.

- 1 Compensating screw for top roller
- 2 Top rollers fold out
- 3 Bottom roller
- 4 Hand crank for height adjustment
- 5 EMERGENCY STOP button
- 6 Electric box with main switch
- 7 Pedals:
 - right pedal rotation right,
 - left pedal turning left
- 8 Anchoring point
- 9 Safety line



Fig. 6: Description of the RBM E

Pedal

The standard pedal is equipped with an EMERGENCY STOP button, which immediately interrupts all machine movements when disconnected from the power connection until it is released.

Function:

right pedal: turn right,

left pedal: direction of rotation left

6.1 Specification and standard equipment

- Asymmetric 3-roller system with swing-out top roller
- Two rollers driven by gears
- Hardened rollers (ST 1050 high-pressure steel)
- Cast iron frame
- Mobile control panel
- Conical-bender
- Operating manual
- EU standard according to (CE mark)

6.2 Optional equipment

- Motor-adjustable / deliverable rear roller
- Hardened rollers for stainless steel

6.3 Safety switch

For the safety of the operating personnel, the machine is equipped with a safety switch and a safety line. When the leash is operated, the ring shown below is pulled like the EMERGENCY STOP, stopping all machine activities.

To restart, pull the blue button (Fig. 7). When the line is pulled, a green mark is visible. The machine can be restarted from the control panel with the START button.

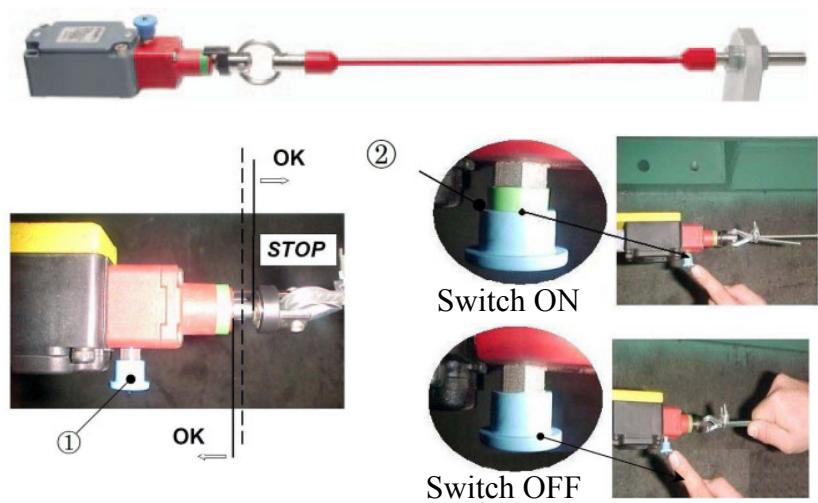

Fig. 7: Safety switch and safety line

7 Set up and connection

7.1 Set up

Requirements for the installation site

In order to achieve good functionality and long life of the bender, the site should meet the following criteria.

- The substrate must be level, firm and vibration-free.
- The installation or working room must be dry and well ventilated.
- Do not operate machines that cause dust and chips near the bender.
- There must be sufficient space for the operating personnel, for material transport as well as for adjustment and maintenance work.
- The site must have good lighting.

Space requirement

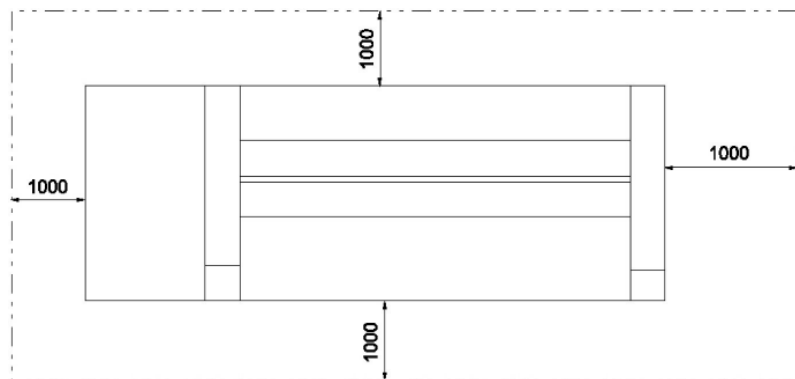

Fig. 8: Space requirement of the machine

The measure of the space requirement on the right side of the machine should be slightly larger than a roll length and allow easy material removal.

The amount of space required in front of and behind the machine should be calculated so that the operator can easily feed the material and remove it from the machine.

Set up the plate rolling machine



WARNING!

Risk of crushing!

The machine may tilt during deployment and cause serious injury.

- The machine must be set up by at least 2 people together.



Wear safety gloves!



Wear safety shoes!



Wear protective clothing!

Step 1: Check the ground for a horizontal alignment, if necessary, compensate for slight unevenness.

Step 2: Attach the round bending machine with ground anchors to the ground and align horizontally with a spirit level.



NOTE!

After setting up, remove the protective agent from the bare metal parts, which have been applied to protect against rusting.

- Use usual solvents.
- No water, no nitrolic solvents or similar use!



NOTE!

The moving parts must be free of dirt and dust.

- If necessary, lubricate the moving parts as listed in the chapter on cleaning and maintenance.

7.2 Danger zones

The plate rolling machine is provided with the necessary protective equipment to prevent injuries that may be caused by the worm gear or other gears. Another area of danger that must be carefully observed during the machining process is the turning range of the rollers.

The danger area shown below must be kept clear during operation.



Fig. 9: Danger zones

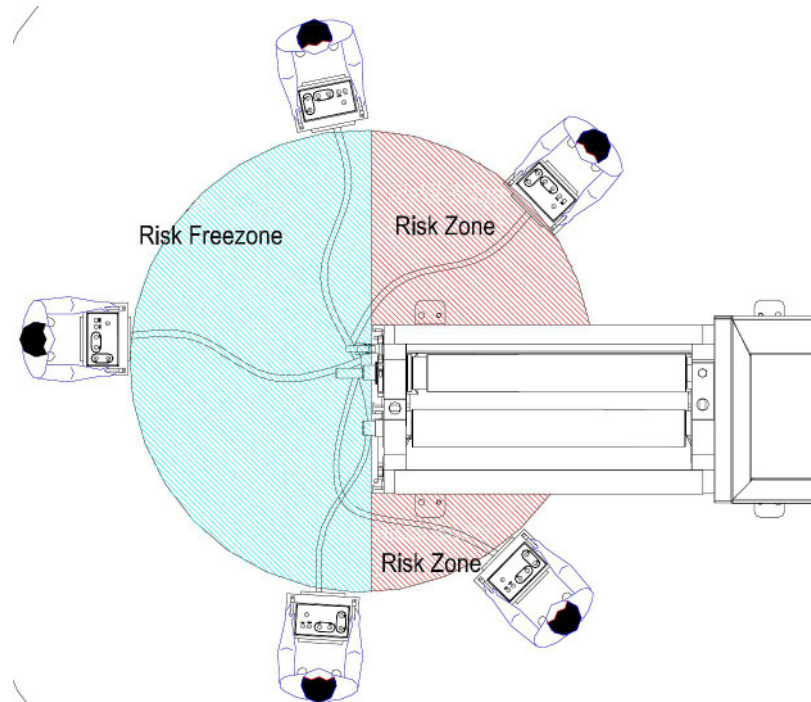



Fig. 10: Position of the operator during the bending process (green area)

7.3 Assembly of the safety line

DANGER!



The safety line is an important safety device and must never be removed during machine operation. Disassembly is only permitted for transport purposes.

The safety line is supplied in its individual components for packaging reasons and must be attached to the machine by the customer as shown below.

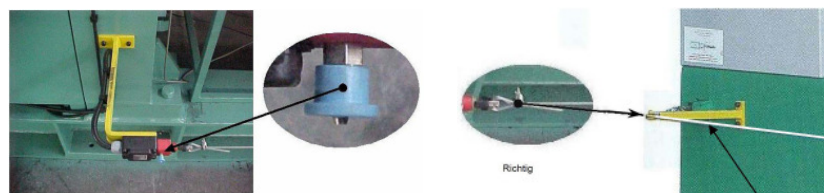

Fig. 11: Assembly of the safety line

It is essential that the leash is firmly attached to the safety switch.

7.4 Lubricate bearings

Before using the machine for the first time, check and lubricate the bearings and gears, see chapter "Cleaning and lubrication".

7.5 Electrical connection

DANGER!



Danger to life due to electric current!

There is an immediate danger of electrocution on contact with live components.

- The machine may only be connected by qualified electricians.
- Work on the electrical system should only be carried out by qualified electricians.

It is important to note that

- the power connection has the same characteristics (voltage, mains frequency, phase) as the motor,
- the mains voltage of 400 V is used,
- For the purpose of a safe working operation the grounding has to be checked.

DANGER!



After connecting the plug, check the direction of rotation of the motor. If this is wrong, two phases must be exchanged.

Step 1: Connect the power cord to the mains.

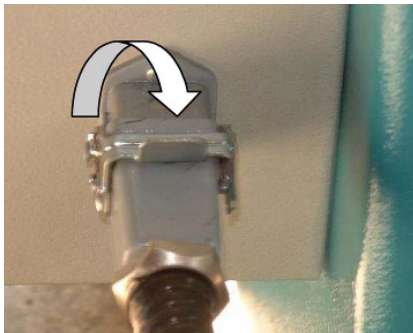

Step 2: Plug the pedal connector into the machine.

In some cases, a reverse connection may cause the motor to burn out. To avoid this, after making the electrical connection, make sure that the direction of rotation corresponds to the indicated direction of the arrow. It can also be checked whether the rolling direction of rotation is carried out according to the operation of the respective keys on the control panel or according to the operation of the respective pedal; right pedal: direction of rotation right; left pedal: direction of rotation left. Possibly. If the direction of rotation is reversed, re-connect the cables.

Fig. 12: Insert pedal plug

Electrical Box

The electric box contains the control elements of the machine and is connected to the pedals.

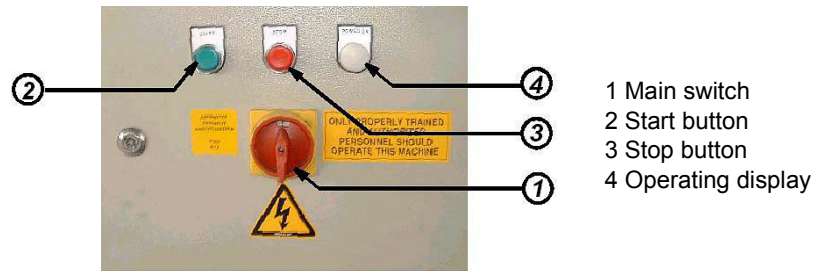



Fig. 13: Electrical box

WARNING!



The main power supply should be protected by circuit breakers against possible overvoltages!

DANGER!



The electric box may only be opened for maintenance and adjustment work!

7.6 Direction of rotation of the motor

Step 1: Turn on the main switch and the ON / OFF switch.

Step 2: Press the START button.

Step 3: Operate the pedals and check the direction of rotation of the rollers.

If necessary, the connections must be reconnected by an electrician to obtain the correct direction of rotation.

8 Commissioning

WARNING!



Danger due to insufficient qualification of persons!

Insufficiently qualified personnel can not assess the risks involved in handling the device and expose themselves and others to the risk of serious or fatal injuries.

- All work should only be carried out by qualified persons.
- Keep inadequately qualified persons out of the work area.

WARNING!



Risk of crushing!

The upper limbs must be kept away from the machine during insertion and during machining of the workpiece.

DANGER!



The following rules must be followed.

- Never carry out any work on the device under the influence of alcohol, drugs or medication and / or in case of fatigue or concentration-impairing illnesses.
- The machine may only be operated by a trained person.



Wear safety gloves!



Wear safety shoes!



Wear protective clothing!

NOTE!



Before commissioning, the following must be observed.

- The mains voltage must correspond to the voltage specifications on the rating plate.
- The main switch must be set to "0".
- The safety devices as well as the protective covers must be functional.

The machine is designed for steel processing and not for processing flammable or harmful substances. The customer is responsible for the choice of the material to be processed. Likewise, care must be taken to ensure the safety of nearby operating personnel.

The material should meet the following requirements:

- Dry and clean, free of oil.
- The diameter must correspond to the specifications.
- The material should have a degree of hardness throughout.
- Buying high quality material is advisable
- The surface of the areas to be bent should be smooth.

NOTE!



It is important to thoroughly clean the rollers to avoid possible slippage of the profile due to grease residues on the rollers.

DANGER!



- The operator should have basic knowledge of this type of machine.
- Operators should not wear loose clothing, necklaces, rings, etc. to prevent them from being pulled into the running machine.
- If faults occur, immediately actuate the EMERGENCY STOP button.

8.1 Operation

CAUTION!



First read the operating instructions!

Please read the operating instructions completely before you start the machine for the first time!

DANGER!



Before using the round bending machine for the first time, lubricate the chains and bearings!

We assume no liability for damage due to improper commissioning.

DANGER!



When operating the rollers: Do not drive the rollers against the lower stop!

The RBM E models have a driven rear roller. It is moved by the engine and a transmission system. The lower roller is driven by the transmission system. Therefore, the bending process is simple and smooth; however, some experience is needed to work efficiently.

A complete bend with one pass is not possible. To get the desired radius, several passes are required. Narrow arcs and full radii always require multiple passes.

Standard operation

In order to be able to remove a bent workpiece from the machine, the lock of the top roller must be released and the top roller must be removed from the guide.



Fig. 14: Release lock of top roller

Step 1: Before starting the machine, check the locking of the top roller.

Step 2: Check the parallelism of the rollers with a gauge and spirit level.

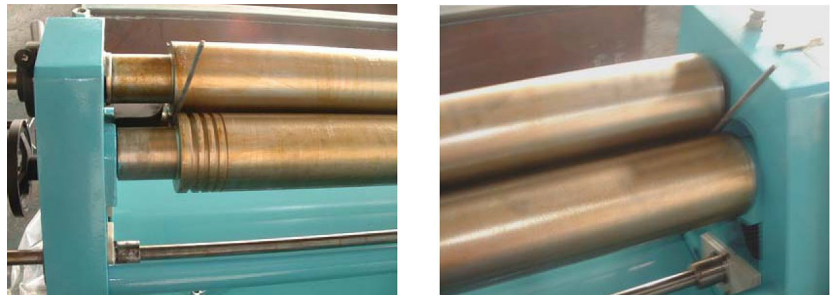

Fig. 15: Check parallelism of rollers

Step 3: Turn on the main switch. The operating display lights up.

Step 4: Press the START button.

Step 5: Press the rollers with the pedals.

Step 6: Perform Bending.

Step 7: Stop the rollers after completing the bending process. Move the front and rear rollers downwards.

Step 8: Loosen the lock of the upper roller, fold out the upper roller and remove the workpiece. Use a crane to support the workpiece.

DANGER



The unfolded top roller must not be overloaded by the workpiece. The workpiece must be supported by a crane.

Step 9: Fold in the top roller and lock.

Step 10: Turn off the machine with the main switch.

8.2 Bending operation

Bending may only be performed by qualified personnel experienced in these machines. All steps of bending, pre-bending and conical bending must be carried out extremely carefully. It should be noted that a small radius is made by repeating the bending process several times; Once too much bent, this step can not be undone.

WARNING



It is not allowed to use profiles exceeding the specification strength. Do not work on more than one piece at a time. Use the machine only for the intended purpose.

8.2.1 Before operation with the machine

- Remove dirt and oil from the material.
- The material ends must be free of chips and burnt residues.
- Burnt material is harder at the points of separation than in the remaining area.
- The material has to be level.
- It is recommended to make a stencil made of cardboard or cardboard for the desired radius
- Always work the workpiece in the center of the rollers

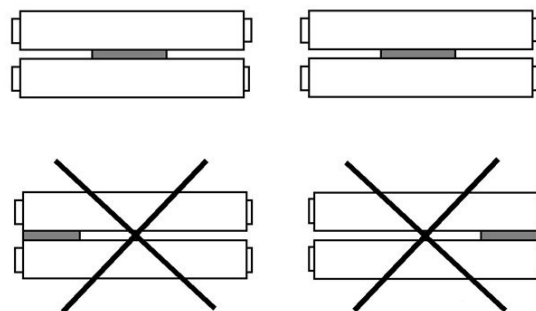
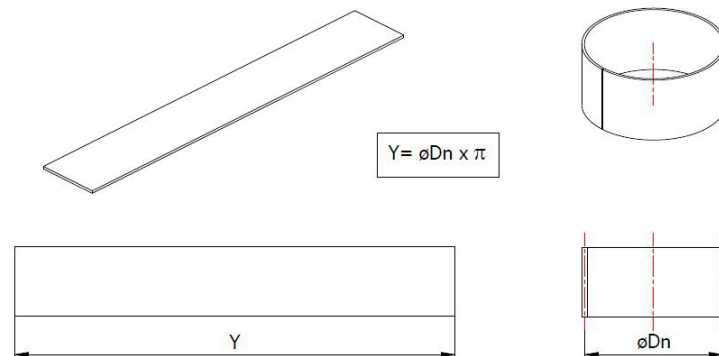

Fig. 16: Position workpiece in the middle of the rollers

Calculation of the workpiece length



8.2.2 Sheet position

Bending chart

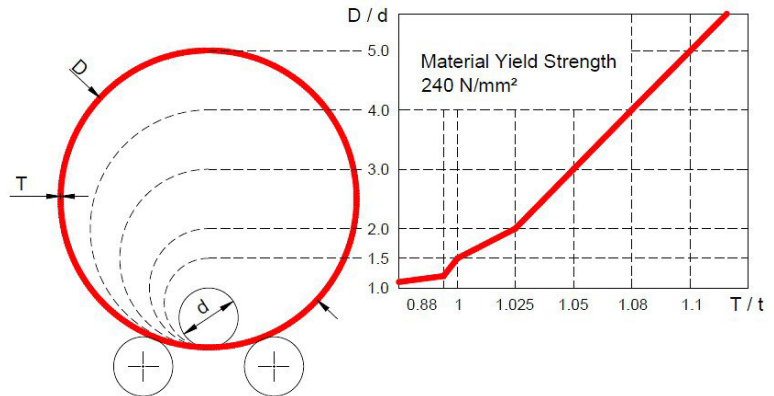

8.2.3 Pre-bending

Pre-bending is the operation whereby the ends of the material are bent to the same radius as the final radius. This will give the best results at full radii (eg making tubes) or for operations where no flat ends are desired.

8.2.4 Bending

NOTE!



The material hardens after each pass. When processing stainless steel, several passes must be made because this material is work hardening material.

Top and bottom roll in straight position

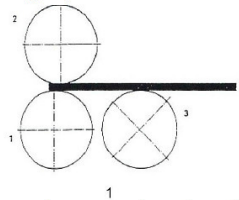

For finishing pre-bending bring the rear roll upwards

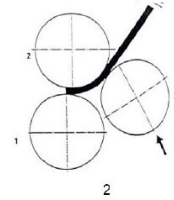

Turn sheet metal and position it for the second pre-bending

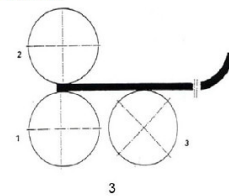

For finishing pre-bending bring the rear roll upwards

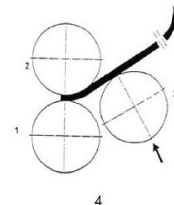

Roll until the desired diameter is achieved

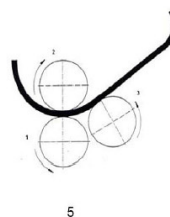

Last pass

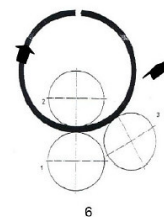

8.2.5 Conical bending

Conical bending is more difficult than normal bending. The machine performance is reduced by 30% to 50%, the conical bending capacity decreases by about 25%. The material thickness must be reduced accordingly..

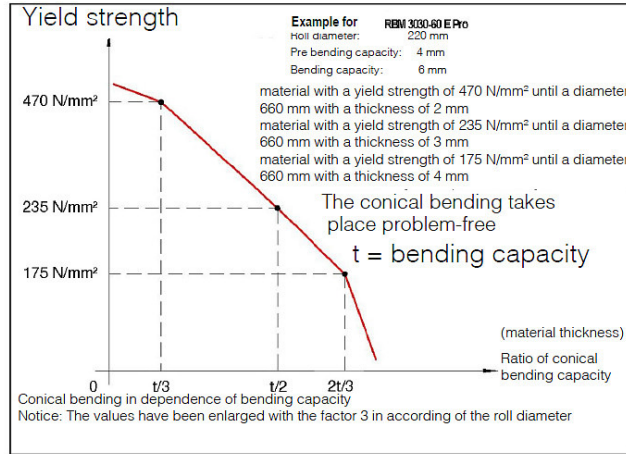

Calculation of the dimension of the workpiece

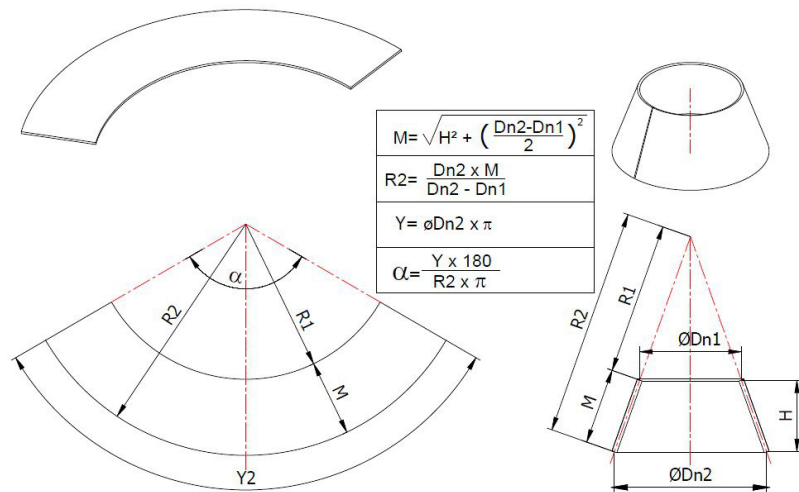

Bending process

Step 1: Before conical bending, the sheet must be pre-bent at the ends with parallel rolls.

Step 2: Thereafter, the machine must be prepared for conical bending as follows:
Move the lower roller and the rear roller to the lowest position.

Conically-bending tool

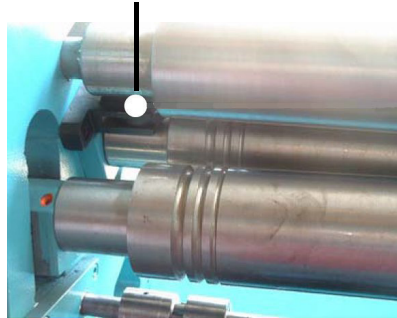

Clutches

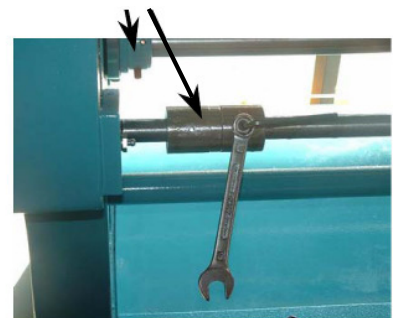

Fig. 17: Conical bending: tool (left) and couplings (right)

Release the fastening bolts of the couplings. Pull off couplings so that only one side of the rollers moves. Use the handwheel to tilt the rollers to the desired position for conical bending.

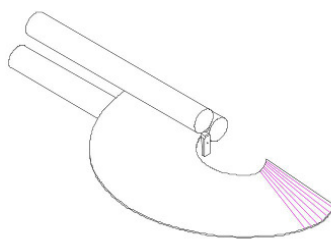
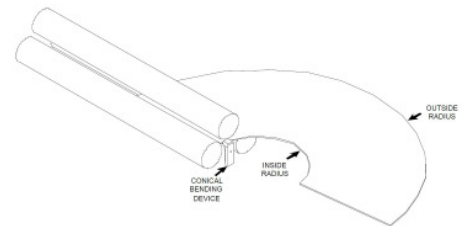

Fig. 18: Conically bending, preparation

The above-illustrated hardened bending tool holds the material to be bent conically during the bending operation.

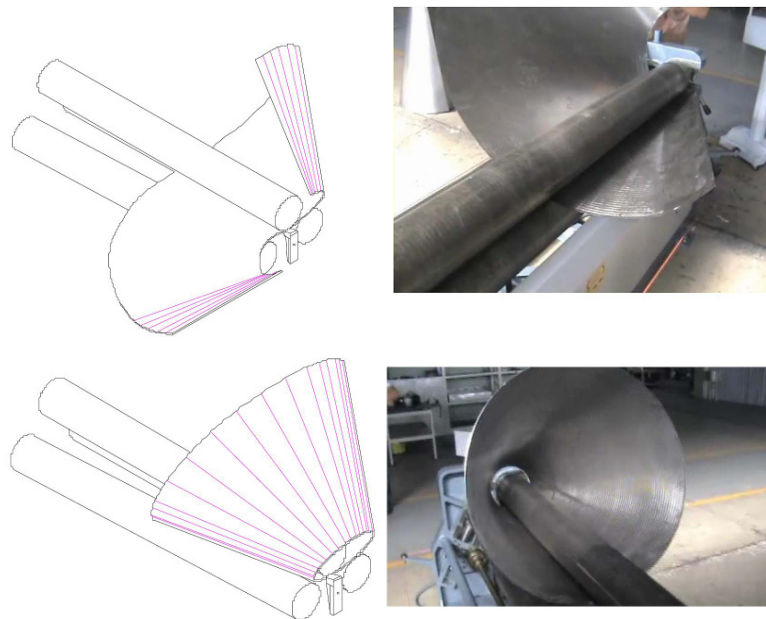

Fig. 19: Conically bending, drain

8.2.6 Normal bending after conical bending

After conical bending, the rollers must be brought back into parallel position.

Step 1: Use the handwheels to bring the back roll and bottom roll parallel to the top roll.

Step 2: Connect couplings.

Step 3: Check the parallelism of the rollers with a gauge.

8.2.7 Removal of the workpiece

Step 1: After completing the bending process, support the workpiece with a crane.

Step 2: Lower the lower and rear rollers.

Step 3: Release the upper roller lock by pulling the handle as far as possible to allow the roller to move in the bearing (Fig. 20).

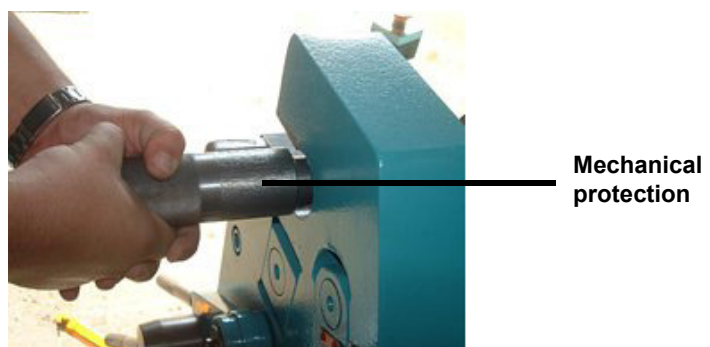

Fig. 20: Release lock of top roller

Step 4: Swing top roller (Fig. 21).

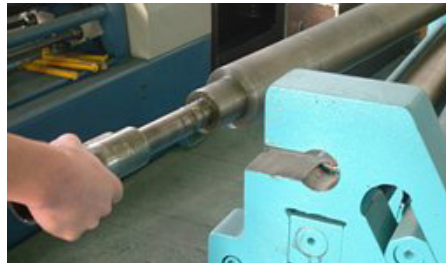

Fig. 21: Swing the top roller

Step 5: Remove workpiece. Use a crane to support the workpiece.



DANGER

When the top roller is tilted, the top roller must not be overloaded by the workpiece. The workpiece must be supported by a crane.

Step 6: Swing the top roller back into the bearing and lock it with the mechanical lock. Make sure that the mechanical lock has been made correctly.

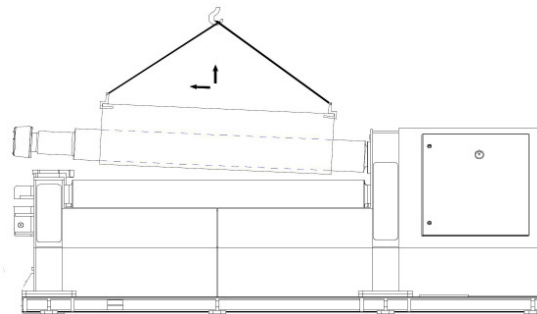

Fig. 22: Workpiece removal with lifting device



WARNING!

Do not change safety device. Never try to activate a function of the machine when the top roller is open.

8.2.8 Counterweight

At the top of the housing of the top roller is the screw for the balance weight. It prevents the top roller from tilting too far when extending.

- Turn clockwise (CW) for more counterweight.
- Counterclockwise (CCW) turning for less counterweight.

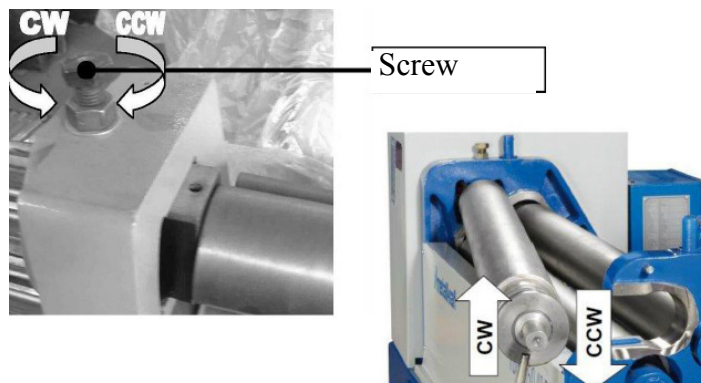

Fig. 23: Adjust balance weight

9 Maintenance and Cleaning



Tips and recommendations

To ensure that the bending machine is always in good operating condition, regular care and maintenance work must be carried out.



WARNING!

Danger due to insufficient qualification of persons!

Insufficiently qualified personnel can not assess the risks involved in maintenance work on the machine and expose themselves and others to the risk of serious injury.

- All maintenance work should only be carried out by qualified persons.



DANGER!

Danger to life due to electrical shock!

There is a danger to life when in contact with live components.

- Always unplug the appliance before cleaning and maintenance.
- Connections and repairs of the electrical equipment may only be carried out by a qualified electrician.



NOTE!

After servicing, maintenance and repair, check that all panels and guards are properly installed on the machine and that there is no more tool inside or in the working area of the machine.

Damaged protective devices and parts of the device must be repaired or replaced as agreed by a recognized specialist workshop.

9.1 Cleaning and lubrication of the machine



DANGER!

Before starting cleaning and lubrication, be sure to switch off the machine and disconnect the power plug!



DANGER!

The rollers must not be lubricated or oiled. You would allow slipping of the material and thus trigger no bending process. The rollers are always free of grease and oil.

- Regularly clean the round bending machine.
- Treat bare metallic work surfaces with anti-rust spray.
- Clean the rollers regularly.

The points listed in the table must be lubricated regularly at least once a month or more often for a period of more than eight hours daily. Some of these locations are inside the machine and can only be accessed after removing the cover.

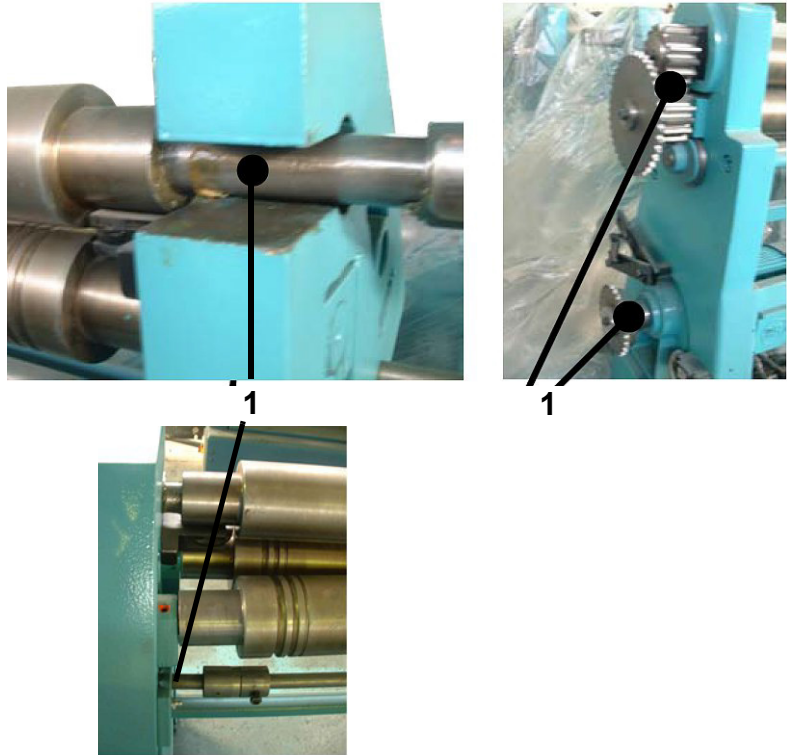

Fig. 24: Parts to be lubricated on the machine

Nr.		Interval	Lubricant
1	Bearings, gears	weekly	Grease

- The gearbox under the front cover is maintenance-free and need only be checked from time to time.
- The engine and frame mounting screws are tightened if necessary.

9.2 Troubleshooting

Fault	Possible cause	Remedy
The machine does not work.	<ol style="list-style-type: none"> 1. Defective electrical connection 2. Switch in the OFF position 	<ol style="list-style-type: none"> 1. Check the electrical connection. 2. Switch in ON position 3. Contact the service.
Engine is running, but the rollers are not moving.	<ol style="list-style-type: none"> 1. Mechanical problem 	<ol style="list-style-type: none"> 1. Check mechanics 2. Contact the service.
The machine does not bend the material.	<ol style="list-style-type: none"> 1. Wrong material. 2. Oily material 	<ol style="list-style-type: none"> 1. Check material. 2. Clean material.
Problem with bending thick sheet metal	<ol style="list-style-type: none"> 1. Check if the sheet thickness is within the permissible dimensions. 2. Workpiece surface is uneven. 	<ol style="list-style-type: none"> 1. The max. permissible material thickness must not be exceeded. 2. Use only flat workpieces.

10 Disposal, recycling of used devices

Please take care in your own interest and in the interest of the environment that all component parts of the machine are only disposed of in the intended and permitted way.

10.1 Decommissioning

Immediately decommission disused machines in order to avoid later misuse and endangering of the environment or personal safety.

- Eliminate all environmentally hazardous operating materials from the used device.
- If required, disassemble the machine into easy to handle and usable components and parts.
- Dispose of machine components and operating materials by the disposal channels provided.

10.2 Disposal of electrical equipment

Electrical equipment contains a variety of recyclable materials and environmentally harmful components.

These components must be separated and properly disposed of. If in doubt, contact municipal waste management.

If necessary, the help of a specialized waste management company can be used for the treatment.

10.3 Disposal of lubricants

Remove any leaking, used or excessive grease at the lubricating points.

Disposal notes for used lubricants are available from the manufacturer of the lubricants. If necessary, request the product-specific data sheets. The disposal instructions for the lubricants used are provided by the lubricant manufacturer. If necessary, ask for the product-specific data sheets.

11 Spare parts



DANGER!

Danger of injury due to use of wrong spare parts!

The use of incorrect or faulty replacement parts may cause danger to the operator and cause damage and malfunction.

- Only original spare parts from the manufacturer or replacement parts approved by the manufacturer must be used.
- In case of doubt, always contact the manufacturer.



Tips and recommendations

It must be used bending rollers that are suitable for the material to be processed.

11.1 Ordering spare parts

The spare parts may be purchased with the authorized dealer or directly with the manufacturer. Please find the corresponding contact data in Chapter 1.2 Customer service.

Indicate the following basic information for requests or orders of spare parts:

- Type of device
- Item No.
- Position No
- Year of construction:
- Quantity
- Required mode of dispatch (mail, freight, sea, air, express)
- Address of dispatch

Spare part orders which do not include the above indications may not be taken into consideration. If the indications regarding the mode of dispatch are missing, the product is dispatched at the discretion of the supplier.

You will find information regarding the device type, item No. and year of manufacture on the type plate fixed to the Machine.

Example

The top roller for the RBM 2050-15 E round bending machine must be ordered. This is indicated in the spare parts drawing with the item number 5.

- Type of device: Plate rolling machine RBM 2050-15 E
- Item number: 3813204
- Position number: 5

Your order number is: **0-3813204-05**

The order number consists of the item number, the position number and one digit in front of the item number.

- Place the digit 0 in front of the item No.
- Also place the digit 0 in front of the position No 1 through 9.

11.2 Spare parts drawing

In case of service, the following drawing shall help to identify the necessary spare parts. If necessary, send a copy of the parts drawing with the marked components to your authorized dealer.

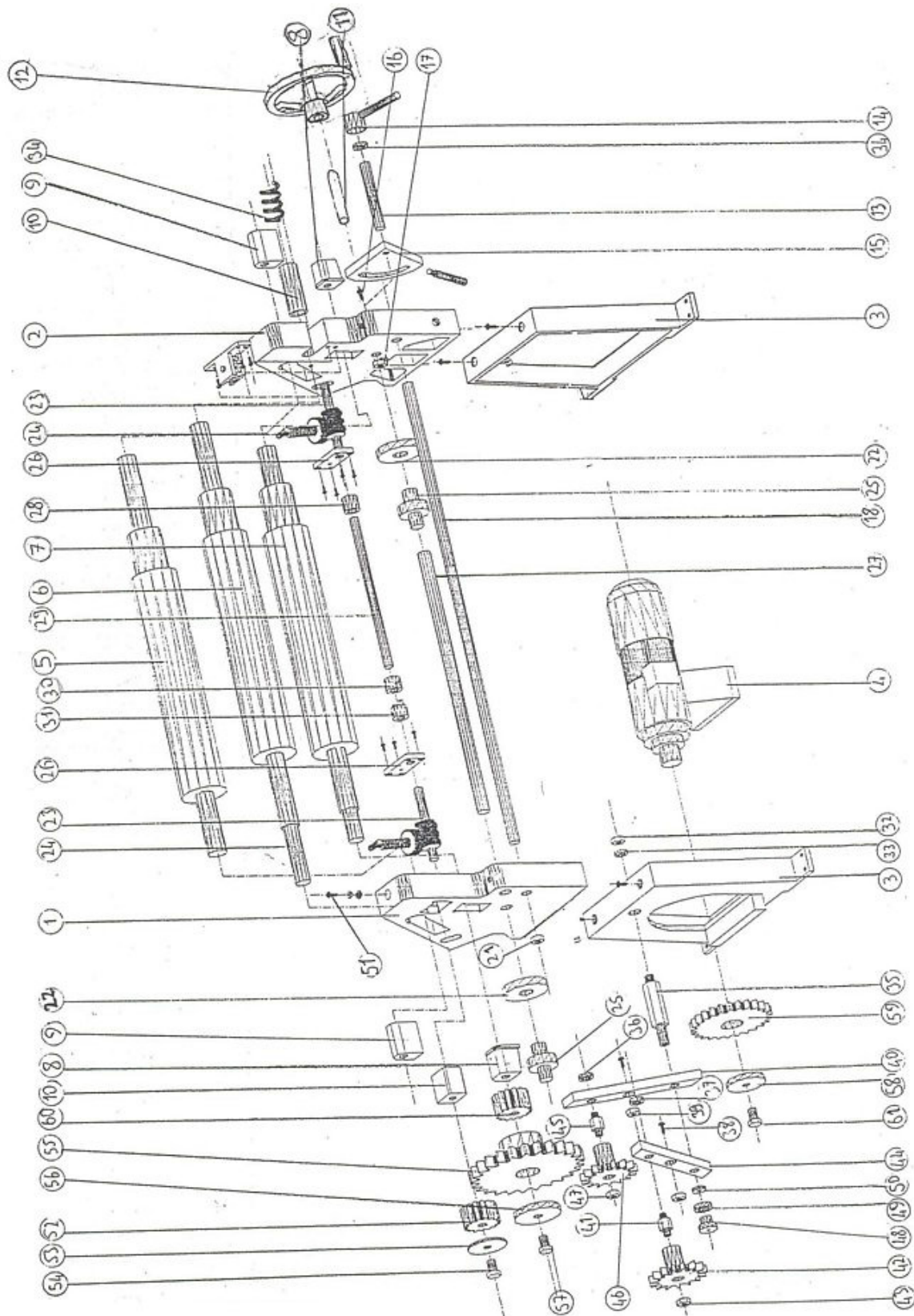

Fig. 25: Spare parts drawing

12 Electrical-schematic

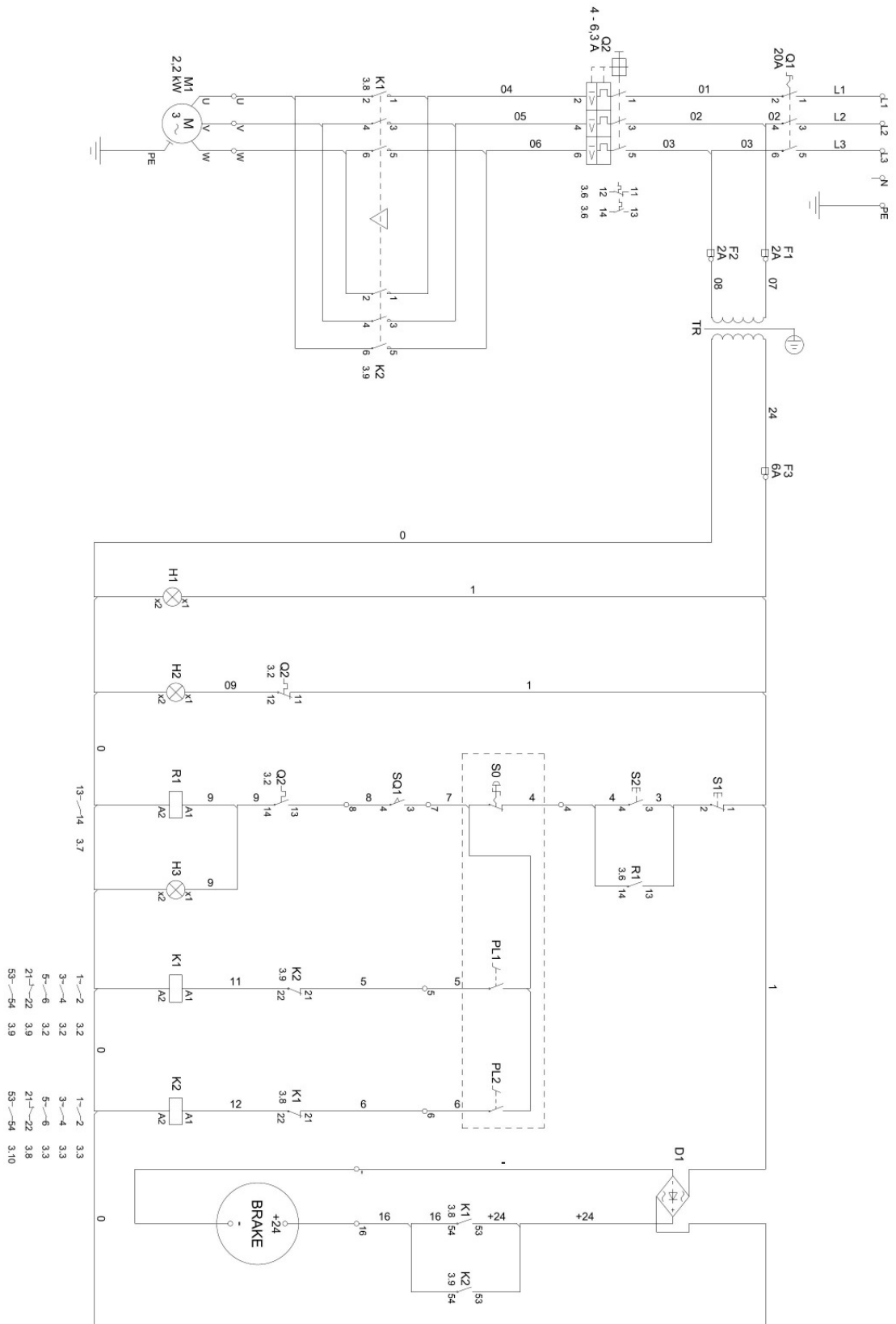

Fig. 26: Electrical-schematic

13 EC Declaration of Conformity

According to machine directive 2006/42/EC Annex II 1.A

Manufacturer/retailer: Stürmer Maschinen GmbH
Dr.-Robert-Pfleger-Str. 26
D-96103 Hallstadt

herewith declares that the following product

Product group: Metalkraft® Metalworking machines

Designation of machine: RBM 1050-30 E
RBM 1270-25 E
RBM 1550-20 E
RBM 2050-15 E

Machine type: Plate rolling machine

Serial number: _____

Year of manufacture: 20____

corresponds, on the basis of its design and construction, as well as the version that we have put into circulation, with the relevant fundamental health and safety requirements of (subsequent) EC guidelines.

Relevant EU directives 2014/30/EU EMC-Directive

The following harmonized standards were applied:

EN 60204-1:2007-06 Safety of machinery - Electrical equipment of machines - Part 1: General requirements

DIN EN ISO 12100:2010 Safety of machinery - General principles for design -Risk assessment and risk reduction (ISO 12100:2010)

Responsible for documentation: Kilian Stürmer, Stürmer Maschinen GmbH,
Dr.-Robert-Pfleger-Str. 26, D-96103 Hallstadt

Hallstadt, 15.04.2016



Kilian Stürmer
General Manager



14 Notes

