

# Instruction Manual

— Compressing and stretching machine

— SSG 12



SSG 12

SSG 12

## Imprint

### Product identification

Compressing and stretching machine	Item number
SSG 12	3776102

### Manufacturer

Stürmer Maschinen GmbH  
Dr.-Robert-Pfleger-Str. 26  
D-96103 Hallstadt/Bamberg

Fax: 0049 (0) 951 96555 - 55

E-Mail: [info@metalkraft.de](mailto:info@metalkraft.de)  
Internet: [www.metalkraft.de](http://www.metalkraft.de)

### Original operating instructions

Original operating instructions

Edition: 27.11.2019  
Version: 2.02  
Language: English

Author: FL

### Indications regarding the copyright

Copyright © 2019 Stürmer Maschinen GmbH, Hallstadt, Germany.

The contents of these operating instructions is the sole property of the company Stürmer Maschinen GmbH. Passing on as well as copying of this document, the use and distribution of its content are prohibited if not explicitly permitted. Contraventions are liable to compensation.

Subject to technical modifications and error.

## Contents

<b>1 Introduction .....</b>	<b>3</b>
1.1 Copyright .....	3
1.2 Customer service.....	3
1.3 Limitation of liability.....	3
<b>2 Safety .....</b>	<b>3</b>
2.1 Symbol explanation .....	3
2.2 Obligations of the operating company .....	4
2.3 Requirements to staff.....	4
2.4 Personal protective equipment .....	5
<b>3 Intended Use.....</b>	<b>5</b>
3.1 Residual risks .....	5
<b>4 Technical Data.....</b>	<b>6</b>
4.1 Table.....	6
<b>5 Transport, package and storage.....</b>	<b>6</b>
5.1 Delivery and Transport .....	6
5.2 Packaging .....	6
5.3 Storage .....	6
<b>6 Description of the device .....</b>	<b>6</b>
6.1 Illustrations.....	6
6.2 Scope of delivery .....	6
6.3 Accessories .....	6
<b>7 Operation .....</b>	<b>6</b>
7.1 Structure and function.....	7
7.2 Operation and adjustment .....	7
<b>8 Cleaning, maintenance and service/repair..</b>	<b>7</b>
8.1 Cleaning.....	7
8.2 Repair .....	7
<b>9 Disposal, recycling of old equipment ...</b>	<b>8</b>
9.1 Decommission .....	8
<b>10 Spare parts .....</b>	<b>8</b>
10.1 Ordering spare parts.....	8
<b>11 Spare parts drawing.....</b>	<b>9</b>

## 1 Introduction

With the purchase of the device of METALLKRAFT you have made a good choice.

**Thoroughly read the operating instructions before commissioning the machine.**

It informs you about the proper commissioning, the intended use as well as the safe and efficient operation and maintenance of your device.

The operating instructions are part of the device. It must always be stored at the place of use of the device. In addition, the local accident prevention regulations and general safety regulations apply to the area of application of the device.

The illustrations in these operating instructions serve the general comprehension and may deviate from the actual type.

### 1.1 Copyright

The contents of these instructions are copyright. Their application is admissible in the frame the device utilisation. An application beyond the described application is not allowed without written approval of the manufacturer. For the protection of our products, we shall register trademark, patent and design rights, as this is possible in individual cases. We strongly oppose any infringement of our intellectual property.

### 1.2 Customer service

Please contact your dealer if you have any questions about your machine or technical information. There you will be happy to help with expert advice and information.

#### Germany:

Stürmer Maschinen GmbH  
Dr.-Robert-Pfleger-Str. 26  
D-96103 Hallstadt

#### Repair-Service:

Fax: 0049 (0) 951 96555-111  
E-Mail: [service@stuermer-maschinen.de](mailto:service@stuermer-maschinen.de)

#### Spare part orders:

Fax: 0049 (0) 951 96555-119  
E-Mail: [ersatzteile@stuermer-maschinen.de](mailto:ersatzteile@stuermer-maschinen.de)

We are always interested in valuable experience and knowledge gained from using the application-which then could be shared and be valuable to develop our products even further.

## 1.3 Limitation of liability

All information and notes in these operating instructions were summarised taking the applicable standards and rules, the state-of-the-art and our long-term knowledge and experiences into consideration.

In the following cases the manufacturer is not liable for damages:

- Non-observance of the operating instructions,
- Inappropriate use,
- Use of untrained staff,
- Unauthorised modifications,
- Technical changes,
- Use of not allowed spare parts.

The actual scope of delivery may deviate from the explanations and presentations described here in case of special models, when using additional ordering options or due to latest technical modifications.

The obligations agreed in the delivery contract, the general terms and conditions as well as the delivery conditions of the manufacturer and the legal regulations at the time of the conclusion of the contract are applicable.

## 2 Safety

This paragraph will give you an overview of all important safety packages for the protection of persons as well as for the safe and undisturbed operation. Other task-based safety notes are included in the individual chapters.

### 2.1 Symbol explanation

#### Safety instructions

The safety notes in these operating instructions are highlighted by symbols. The safety notes are introduced by signal words which express the concern of the risk.



#### DANGER!

This combination of symbol and signal words indicate an imminently dangerous situation which may lead to death or severe injuries if they are not avoided.



#### WARNING!

This combination of symbol and signal words indicate a possibly dangerous situation which may lead to death or severe injuries if they are not avoided.



**CAUTION!**

This combination of symbol and signal words indicate a possibly dangerous situation which may lead to minor or light injuries if they are not avoided.



**NOTE!**

This combination of symbol and signal words indicate a possibly dangerous situation which may lead to property and environmental damages if they are not avoided.

**Tips and recommendations**



**Tips and recommendations**

This symbol highlights useful tips and recommendations as well as information for an efficient and trouble-free operation.

It is necessary to observe the safety notes quoted in these operating instructions in order to reduce the risks for personal injuries and damages to property.

**2.2 Obligations of the operating company**

The operating company is the person who operates the machine for business or commercial reasons by herself, or leaves it to a third party for use or application, and who bears the legal product responsibility for the protection of the user, the staff or for third parties.

**Obligations of the operating company:**

If the machine is used for commercial purposes, the operating company must comply with the legal working safety regulations. Therefore, the safety notes in this operating manual, as well as the safety, accident prevention and environment protection regulations applying for the area of application of the machine must be met. The following applies in particular:

- The operating company must be informed about the applying industrial safety regulations and further analyse hazards resulting from the special working conditions at the place of use the machine. She must implement these in form of operating manuals for the operation the machine.
- During the entire lifetime of the machine, the operating company must verify whether the operating manuals prepared by her correspond to the current status of the regulations, and must adapt these if necessary.

- The operating company must unambiguously regulate and determine the responsibilities for installation, operation, troubleshooting, maintenance and cleaning.
- The operating company must ensure that all persons who work with the machine, have read and understood this manual. Furthermore she must instruct the staff in regular intervals and inform them about the hazards.
- The operator must provide the necessary protective equipment to the staff and order the use of the necessary protective equipment in a binding way..

Furthermore the operating company is responsible to keep the machine always in a technically flawless state. Thus, the following applies:

- The operator must ensure that the maintenance intervals described in this manual are kept.
- The operator must have all safety devices checked regularly for their good working order and their integrity.

**2.3 Requirements to staff**

The different tasks described in this manual represent different requirements to the qualification of the persons entrusted with these tasks.



**WARNING!**

**Danger in case of insufficient qualification of the staff!!**

Insufficiently qualified persons cannot estimate the risks while using the machine and expose themselves and others to the danger of severe or lethal injuries.

- Have all works only performed by qualified persons.
- Keep insufficiently qualified persons out of the working area.

Only persons reliable working procedures can be expected from, are allowed to perform all works. Persons the responsiveness of which is affected by e. g. drugs, alcohol or medication, are not allowed to work with the machine.

The qualifications of the personnel for the different tasks are mentioned below:

**Operator**

The operator is instructed by the operating company about the assigned tasks and possible risks in case of improper behavior. Any tasks which need to be performed beyond the operation in the standard mode must only be performed by the operator if it is indicated in these instructions and if the operating company expressly commissioned the operator.

### Electrically qualified person:

Electrically qualified person is due to their professional training, knowledge and experience as well as knowledge of the relevant standards and regulations, in a position to carry out work on the electrical systems and to independently recognize and avoid possible dangers.

### Qualified personnel:

Due to their professional training, knowledge and experience as well as their knowledge of relevant regulations the specialist staff is able to perform the assigned tasks and to recognize and avoid any possible dangers themselves.

### Manufacturer:

Certain works may only be performed by specialist personnel of the manufacturer. Other personnel is not authorized to perform these works. Please contact our customer service for the execution of all arising work.

## 2.4 Personal protective equipment

The personal protective equipment serves to protect persons against impairments of safety and health while working. The staff member has to wear personal protective equipment while performing different tasks on and with the machine which are indicated in the individual paragraphs of these instructions. The personal protective equipment is explained in the following paragraph:



### Ear and head protection

The ear protection protects against hearing damage caused by noise. The industrial helmet protects the head against falling objects and bumping against fixed objects.



### Face protection

The face shield protects the face from flying parts.



### Protective gloves

The protective gloves serve to protect the hands against sharp components as well as against friction, abrasions or deep injuries.



### Safety boots

Safety boots protect the feet from being crushed, falling parts and slipping over on slippery ground.



### Protective clothes

Protective clothes are made of a tightly fitted fabric without the protruding parts of low tear strength.

## 3 Intended Use

The Compressing and stretching machine is used for universal use in the workshop and construction site area for upsetting and stretching sheet metal. The version SSG 12 can handle a maximum sheet thickness of 1.2 mm

Proper use also includes compliance with all information in this manual. Any use beyond the intended use or otherwise is considered misuse.



### WARNING!

#### Danger in case of misuse!

Misuse of the device can lead to dangerous situations.

- Only operate the device in the power range specified in the technical data.
- Never bypass or override the safety devices.
- Only operate the device in a technically perfect condition.

Unauthorized modifications or alterations to the compression and stretching device can invalidate the CE conformity of the compression and extension device and are prohibited. The company Stürmer Maschinen GmbH assumes no liability for design and technical changes to the Compressing and stretching machine.

The improper use of the compression and stretching device as well as the disregard of the safety regulations or the operating instructions exclude a liability of the manufacturer for resulting damage to persons or objects and cause the warranty to expire!

### 3.1 Residual risks

Even if all safety regulations are observed and the machine is used correctly, there are still residual risks listed below:

- Pinching of body parts.
- Injuries from flying workpieces or workpiece parts.
- Danger of breakage of the tool.

## 4 Technical Data

### 4.1 Table

Type	SSG 12
Max. sheet thickness	1,2 mm
Throat	25 mm
Length	150 mm
Width / Depth	50 mm
Height	140 mm
Weight	5,5 kg

## 5 Transport, package and storage

### 5.1 Delivery and Transport

Check the machine on delivery for any visible transportation damage. If you notice any damage to the device please report this immediately to the carrier or dealer.

### 5.2 Packaging

All packaging materials and packing aids used for the hydraulic workshop press are suitable for recycling and must always be disposed of using material-based recycling systems.

Packaging materials made of cardboard must be shredded and disposed of as part of waste paper recycling. The foils are made of polyethylene (PE), padding is made of polystyrene (PS). Dispose of these at a recycling center or hand them over to the relevant waste disposal company.

### 5.3 Storage

Store the device in a dry, clean, dust-free and frost-free environment. It must not be placed in a room with highly oxidising chemicals.

Also, all bare metal parts must be greased against corrosion.

## 6 Description of the device

### 6.1 Illustrations

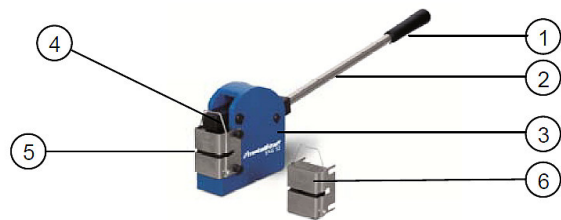

Fig. 1: Description of the device

- 1 - Rubber handle for pressure arm
- 2 - Lever
- 3 - Housing
- 4 - Steel cable
- 5 - Upsetting jaws
- 6 - Cover for compression jaws

### 6.2 Scope of delivery

- Basic machine
- Stretching jaws
- Compression jaws

### 6.3 Accessories

- Compression jaw SET für SSG 12  
**Item number: 3776104**
- Stretching jaw SET für SSG 12  
**Item number: 3776105**

## 7 Operation



### DANGER!

- Always assemble the Compression jaw and Stretching jaw correctly on the body of the device.



**Wear Protective gloves**



**Wear Protective clothes!**

## 7.1 Structure and function

This machine consists of a body part and the upsetting and stretching jaws together. The body of this machine is made of high quality cast steel, with a high strength and a good stability. The upsetting and stretching jaws are made of chrome steel with very high hardness and toughness. The upsetting jaws are used to form external radii and the stretching jaws are used to form internal radii.

## 7.2 Operation and adjustment

Please make sure that the jaws are properly attached to the body of the machine and that the body part is fixedly mounted on a stand. The opening and closing of the tool teeth is only possible by pressing the handle no. 13 (see exploded view). Insert the sheet to be processed in the middle of the jaws and press the handle No. 13  
Note: The work carried out should be carried out within the max. Capacity.



### DANGER!

CRUSHING! When upsetting and stretching is always to make sure that your own security is given. There are crushing hazards on upper limbs.

## 8 Cleaning, maintenance and service/repair



### Tips and recommendations

To ensure that the machine is always in good operating condition, regular care and maintenance work must be carried out.



### WARNING!

#### Danger due to insufficient qualification of persons!

Insufficiently qualified persons can not assess the risks associated with repair work on the upsetting and stretching equipment and expose themselves and others to the risk of serious injury.

- All maintenance work should only be carried out by qualified persons.



### NOTE!

After care, maintenance and repair work, check that all panels and guards are correctly mounted on the upsetting and stretching equipment and that no tools are left inside or in the working area of the upsetting and stretching equipment.

Damaged protective devices and parts of the device must be repaired or replaced as agreed by a recognized specialist workshop.

## 8.1 Cleaning



### NOTE!

Oil, grease and cleaning agents are hazardous to the environment and must not be disposed of in wastewater or normal household waste. Dispose of these funds in an environmentally friendly way. The cleaning cloths soaked in oil, grease or detergent are easily combustible. Collect the cleaning rags or cleaning wool in a suitable, closed container and dispose of them in a manner suitable for environmentally-friendly disposal - do not dispose of with household waste!



### Wear safety gloves!



### Wear Protective clothes!

Clean the machine after each use.

Do not remove metal or scrap with bare hands, but use safety gloves to prevent cuts.

Clean all painted surfaces with a soft, damp cloth.

Never use solvents to clean plastic parts or painted surfaces. A surface release and consequential damage may occur.

## 8.2 Repair

As a result of wear and tear, it may happen that maintenance work must be carried out on the machine.



### ACHTUNG!

Repairs or maintenance may only be carried out by qualified and trained specialist personnel.



**DANGER!**

For maintenance work, please contact your nearest metalworking dealer. Please write down the following information from the machine or the operating instructions in advance to help you with your problem in the best possible way:

- Model of the machine,
- Serial number of the machine,
- Exact error description

## 9 Disposal, recycling of old equipment

In your own interest and to protect the environment make sure that all machine components are exclusively disposed of in as intended and permitted.

### 9.1 Decommission

Disused devices must be taken out of service immediately in order to avoid later misuse and endangering the environment or people.

- remove all environmentally hazardous processing materials from the used machine.
- if necessary, disassemble the machine into assemblies and components that are easy to handle and suitable for recycling.
- The machine components and processing materials must be disposed of using the intended disposal methods.

## 10 Spare parts



**DANGER!**

**Risk of injury caused by the use of incorrect spare parts!**

The use of incorrect or faulty spare parts may cause risks for operating staff and damage as well as malfunctions.

- Exclusively genuine spare parts made by the manufacturer or spare parts authorized by the manufacturer shall be used.
- Always contact the manufacturer if you are unsure.



**NOTE**

The manufacturer warranty shall be rendered void in the event of a use of unauthorised spare parts.

## 10.1 Ordering spare parts

The spare parts can be obtained from the dealer or directly from the manufacturer. The contact details are in chapter 1.2 Customer Service.

Specify the following key data for inquiries or when ordering spare parts:

- Device type
- Article number
- Position number
- Year of manufacture
- Quantity
- Desired shipping type (post, freight, sea, air, express)
- Shipping address

Spare parts orders without the aforementioned data cannot be taken into account. The supplier shall determine the shipping type if no relevant data was provided.

Information about the device type, item number and year of manufacture can be found on the type plate. The type plate is mounted on the device.

### Example

The lever for the Compressing and stretching machine SSG 12 must be ordered. The lever has the number 13 in the spare parts drawing 1.

By ordering spare parts, send a copy of the spare parts drawing (1) with the marked part (lever) and marked position number (13) to the dealer or spare parts department and provide the following information:

- Maschinentyp: Compressing and stretching machine SSG 12
- Item number: 3776102
- Drawing number: 1
- Position number: 13

### Item number of your device:

Compressing and stretching machine SSG 12: 3776102



## 11 Spare parts drawing

The following drawing are intended to identify the required spare parts in the event of service. If applicable, submit a copy of the parts drawing including the highlighted components to your authorized retailer..

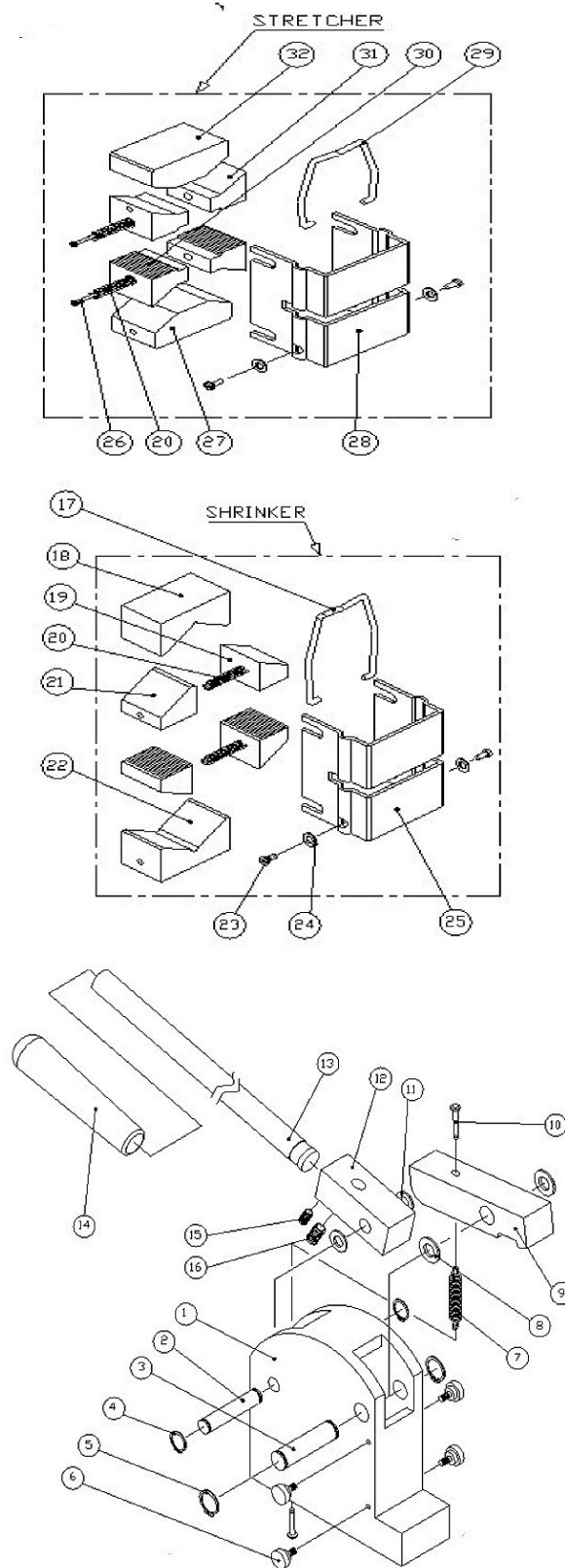

Fig. 2: Spare parts drawing SSG 12

