

Engine Timing Tool Set for Porsche Boxster & 911

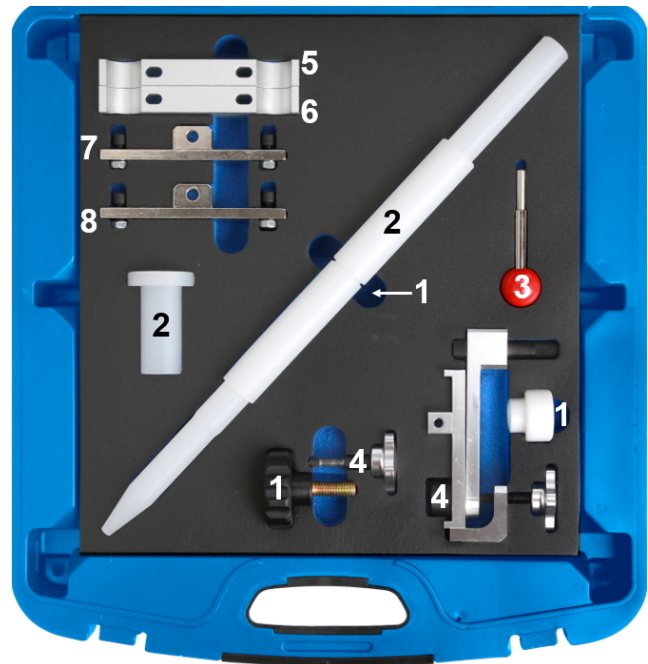

TOOLS

- 1 Piston Pin Driver and Extension
- 2 Connecting Rod Centering Mandrel
- 3 TDC Alignment Pin
- 4 Camshaft Locking Tool
- 5 Camshaft Supporting Tool
- 6 Camshaft Supporting Tool
- 7 Camshaft Holding Tool
- 8 Camshaft Holding Tool

INTENDED USE

This Tool set is made for adjusting and checking the engine timing on following models:
Porsche Boxster (986 / 987) 2.5L (as of 1998), 2.7L (as of 2000), 3.2L (as of 2000),
Porsche 911 (996 / 997) 3.6L (as of 2002), 3.4L (as of 2002)

Further information on the item and a list of suitable engines and models can be found on our website: www.bgstechnic.com

SAFETY INFORMATIONS

- Do not use the set if any parts are missing or damaged.
- Only use this tool for the purpose for which it is intended.
- Never lay tools on the vehicle's battery. This may short the terminals together.
- Be careful when working on running engines. Loose clothes, tools and other things can be caught up in revolving parts which may lead to serious injuries.
- Keep children and other unauthorised persons away from the working area.
- Do not let children play with the tool or its packaging.
- Be careful when working on hot engines – risk of burn!
- Remove the negative battery connection before repairing, so you avoid short circuits and that the engine will not start unintentionally.
- This manual is just brief information and will not replace a garage handbook.
- Always consult specific service literature for information about torques, assemblies and disassemblies etc.
- After any successful maintenance and before starting the engine, you should rotate the engine for two turns manually to check the new control time.
- Turn the crankshaft in the normal direction (clockwise unless stated otherwise) and only at the crankshaft itself, never turn the crankshaft by turning camshaft or another wheel.

USE

Piston Pin Driver and Extension (1),
to be used as OEM 9602

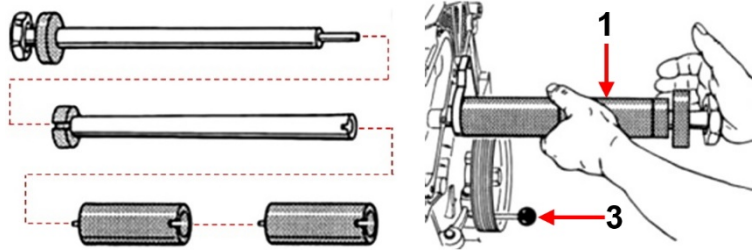

Connecting Rod Centering Mandrel (2),
to be used as OEM 9608

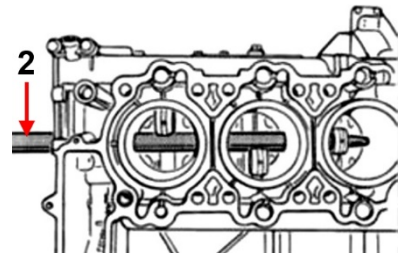

TDC Alignment Pin (3),
to be used as OEM 9595

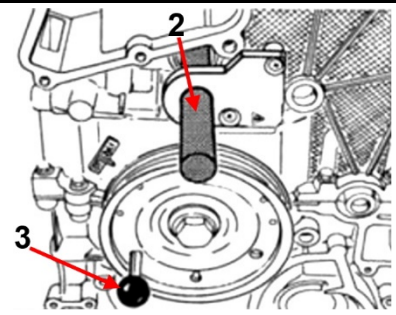

Camshaft Locking Tool (4),
to be used as OEM 9612

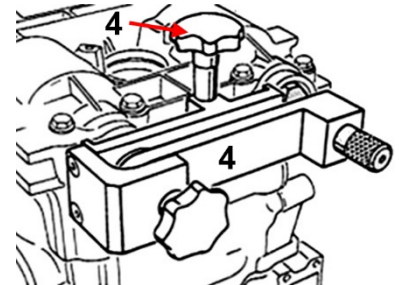

Camshaft Supporting Tool (5-6),
to be used as OEM 9611

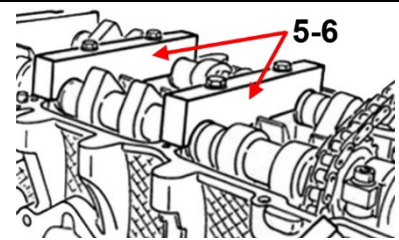

Camshaft Holding Tool (7-8),
to be used as OEM 9634

