

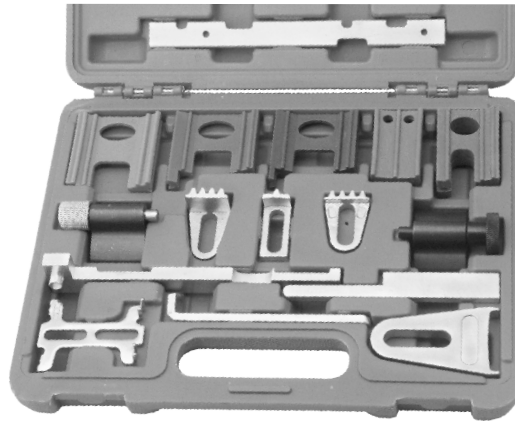

## ENGINE TIMING LOCKING TOOL KIT CT3009



### Warning

It is always recommended to refer to the vehicle manufacturers workshop manual for specific procedures and technical data when using these tools. Incorrect or out of phase engine timing can result in damage to valves. It is always recommended to turn the engine slowly by hand and to recheck the camshaft and crankshaft timing positions.

Our application directory should be used as a guide only and The Tool Connection cannot be held responsible for any damage caused to your engine by using these tools.

### Safety

Care should be taken when working on the engine and full protection should be worn. The Tool Connection cannot be held responsible for any personal injury caused when using these tools.

Component Code	Description	Manufacturer	Model	Engine
NO.1	Twin Camshaft Locking Tool	Vauxhall/Opel	Astra-G 2.0/2.2 Turbo/16v Frontera-B/Omega-B/Sintra-A 2.2 16v, Vectra 1.8/2.0 16v Zafira 2.0 Turbo	X22SE, X22XE, Y22SE, Y22XE, Z22XE, Z20LET X18XE C20SEL, X20XEV
NO.2	Camshaft Locking Tool RH	Vauxhall/Opel  Saab	Calibra/Cavalier V6/V6i 2.5 Omega-BV6 2.5/2.6/3.0/3.2 Sintra 3.0 V6, Vectra-A-B 2.5/2.6 V6/V6i 900,9000,9-5 2.5,3.0 V6	X25XE, X30XE, Y26SE, Y32SE
NO.3	Camshaft Locking Tool LH	Vauxhall/Op  Saab	Calibra/Cavalier V6/V6i 2.5 Omega-BV6 2.5/2.6/3.0/3.2 Sintra 3.0 V6, Vectra-A-B 2.5/2.6 V6/V6i 900,9000,9-5 2.5,3.0 V6	X25XE, X30XE, Y26SE, Y32SE
NO.4	Camshaft Locking Tool	Rover	200 2.0/Turbo/1.6/1.8/1.8 V/ Coupe/Cabrio 1.6 DOHC/1.8/2.0 25 1.1/1.6/1.8/1.8 VVC/2.0 TurboD 400 1.6/2.0D Turbo/2.0/1.6 DOHC/1.8D	K16

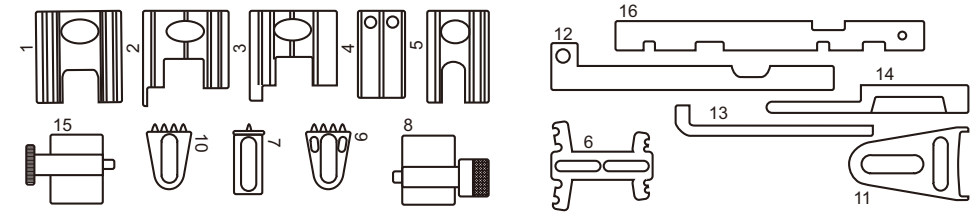

Component Code	Description	Manufacturer	Model	Engine
NO.5	Twin Camshaft Locking Tool	Vauxhall/Opel	Astra-G 1.4/1.6/1.8 16v Corsa-C 1.4/1.8 16v Vectra-B/C 1.4/1.6/1.8 16v Zafira 1.6/1.8 16v	X14XE, X16XEL, X16SEJ, X18E1, Y16XE, Z14XE, Z16XE, Z16YNG, Z18XE, Z18XEL
NO.6	Flywheel Locking Tool	Vauxhall/Opel	Astra-F 1.7 D/TD, Astravan 1.7 D/TD, Cavalier 1.7D, Vectra-A1.7D	17DR X17DTL
NO.7	Flywheel Locking Tool	Peugeot/Citroen	1.8/2.0 16v 1.9 2.1 HDi	XU, XUD, DW
NO.8	Crankshaft Setting Tool	Volkswagen	Golf/Golf Plus/Jetta/Touran 2.0 TDi PD DOHC	AZV BKD Non bored engine
NO.9	Flywheel Locking Tool	Fiat	Ulysse 1.8/2.0/Turbo Ducato 2.0	LFW, RFU, RGX, RFW
NO.10	Flywheel Locking Tool	Renault	Clio, Twingo, kangoo, D7F Megane/Scenic, Laguna, Express/Extra	K7M, K4J, K4M, F4P, F4K F8Q, F9Q
NO.11	Flywheel Locking Tool	Renault	Laguna 2.2 D/TD, Safrane 2.2 D/TD, Espace 2.2 D/TD	G8T
NO.12	Camshaft Setting Bar	Ford	Puma 1.7	MHA, MHB
NO.13	Flywheel Locking Tool	Vauxhall/Opel	Astra-G 1.4/1.6/1.8 16v Corsa-C 1.4/1.8 16v Vectra-B 1.4/1.8 16v Zara-G 1.6 1.8 16v Astra-G 1.4/1.6/1.8 16v Vivaro 1.9 DTi, Meriva 1.6	Z16LET Z16XEP F9Q 76 F9Q 760 X16SZR, Z16SE
NO.14	Camshaft Locking Tool	Vauxhall/Opel	Midi	4FCI-T 4FDi 4GDi
NO.15	Crankshaft Locking Tool	Volkswagen  Audi  Ford  Seat	Beetle/Bora/Golf 1.9 TDi PD Lupo 1.4/12 TDi PD/3L 1.2 Passat 1/9 TDi PD Polo 1.4/1.9 TDi PD Sharan 1.0 TDi PD Golf/Golf Plus/Jetta/Touran 2.0 TDi PD DOHC  A2 1.2/1.4 TDi PD A3/4/6 1.9 TDi PD  Galaxy TDi/PD 1.9  Alhambra/Lron 1.9 TDi PD Arosa 1.4 TDi PD	AVQ, BJB, BKC, BRU AJM, AMF, ANU, ARL, ASZ, ATD, AUY, AXR, BAY, ANY, AYZ (AZV, BKD Non bored engine)
NO.16	Camshaft Setting Bar	Ford	Focus 1.6, Focus C-Max 1.6	HWDA, HWDB

Instruction Manual