

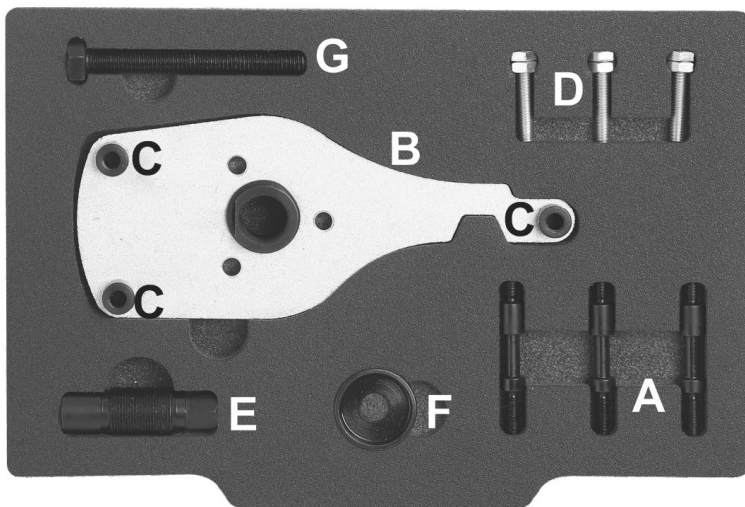

**INJECTION PUMP REMOVER INSTALLER SET
FOR FORD 2.0 ECOBLUE DIESEL
CT5726
INSTRUCTION MANUAL**



CONTENTS

- A Double Ended Stepped Screw x 3 OEM 303-1635/3
- B Injection Pump Plate Replacement Tool OEM 303-1635/1
- C Plate Bolts x 3
- D Stepped Screw Nuts x 3
- E Force Screw OEM 303-1635/2
- F Cover
- G Installation Bolt OEM 303-1635/6

GENERAL

- Injection pump remover and installer for Ford 2.0 EcoBlue diesel.
- Applications: Ford Transit, Transit Custom and Tourneo Custom with 2.0L Ecoblue TDCi
- Engines: AWD, FWD, RWD (from 2016), Focus, Galaxy, S-Max (from 2018) Ranger (from 2019).
- Engine codes: YLFS, YMFS, YNFS, YLF6, YMF6, YNF6, YLR6, YMR6, YNR6, YLDA, BCCC, YM CB, YNCA.
- OEM number 303-1635.

SAFETY INSTRUCTIONS

- Personal protection and safety equipment must be used at all times.
- Eye protection and protective gloves must be worn when using these tools.
- Misuse of tools is unsafe, and can cause engine damage.
- Remove damaged tools from use.
- Store in a dry place when not in use.
- Do not use these tools to torque or loosen fixings unless otherwise stated.

INSTRUCTIONS

Where used

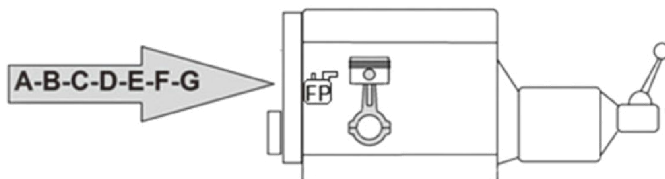

Preparation

It may be necessary to remove: The auxiliary drive belts and tensioner.

Note: More dismantling may be required depending on AWD, RWD and FWD Refer to OEM instructions.

Note: The threaded force screw must be kept clean and lubricated with Molybdenum Disulphide grease. Failure to adequately lubricate the force screw and frame may result in damage .

Remove inspection cover and remove the securing bolt from the injection pump drive gear. Install stepped bolts (A)) Fig. 1.

Place the pump plate (B) onto the three studs and secure with bolts (C) to the cylinder block. Secure the stepped bolts to the plate using nuts (D).

With the diesel injection pump disconnected as per OEM instructions, insert the

lubricated force screw (E) into the pump plate (B) and rotate in a clockwise direction with a suitable wrench to push the injection pump out of the drive gear Fig. 2.

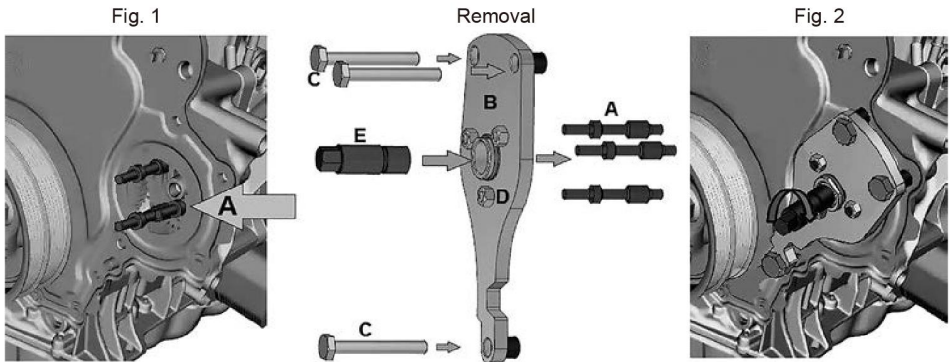

Installation

Remove the force screw (E) and fit the cover (F).

Install injection pump into position.

Slide installation bolt (G) through the pump plate to engage the injection pump Fig. 3, place a small amount of Molybdenum Disulphide Grease on the underside of the bolt head.

Turn installation bolt in a clockwise direction with a suitable wrench to pull the injection pump back through the drive gear back into its mounted position.

Check installation according to OEM instructions.

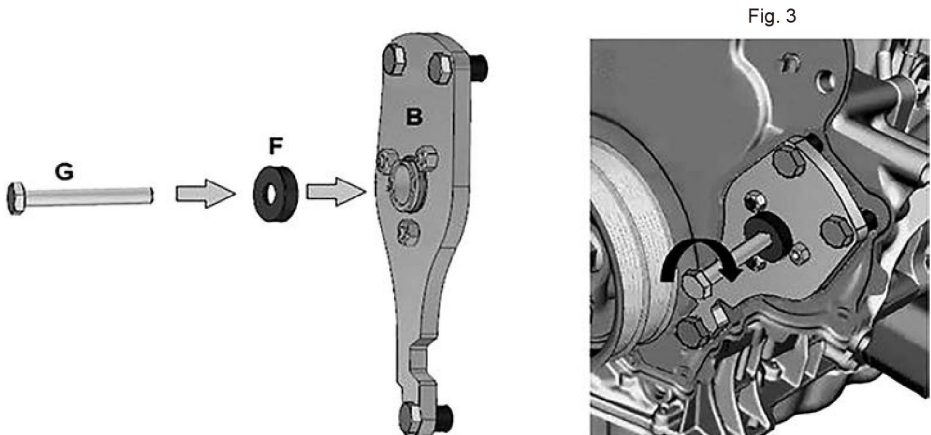

CANNON TOOLS LTD

Add: 20 station road, Rowley Regis, west midlands,B65 0JU.U.K.

www.cannontools.co.uk