

**2021**

# **EL~MAX**

**NUTRUNNER AB**

---

**RESERVDELAR&HYLSOR**

**SPARE PARTS & SOCKETS**

**PARTS & HÜLSEN**

**EL-MAX NUTRUNNER 1,5**

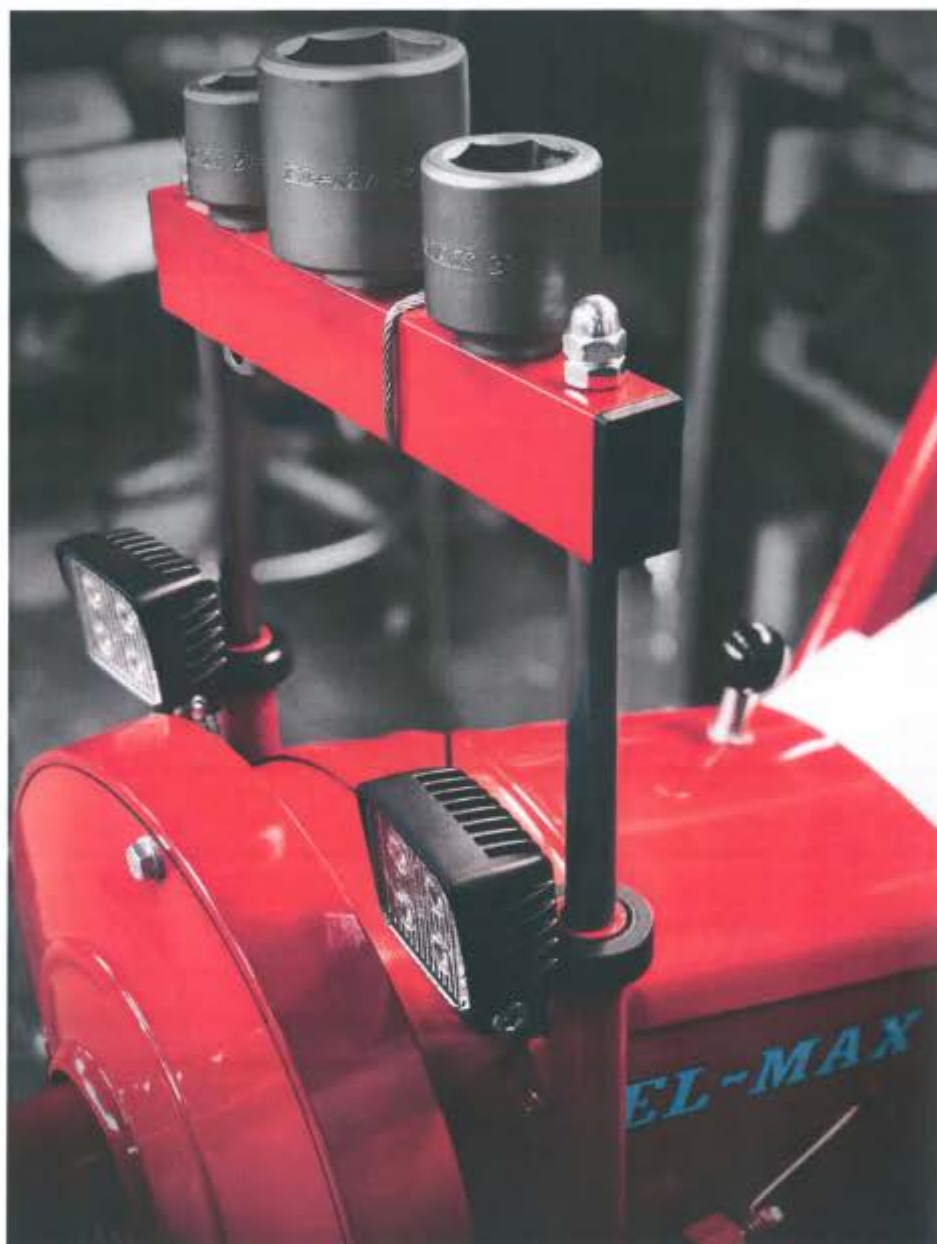

**BRIKLAS**

**VERKTYG & MASKINER**

**040-43 58 58 · Arlöv**

**info@briklas.se · www.briklas.se**



mm			
17	Fyrkant	Square	Vierkant
17	Sexkant	Hexagon	Sechskant
19	Sexkant	Hexagon	Sechskant
20,6	Fyrkant	Square	Vierkant
21	Sexkant	Hexagon	Sechskant
22	Sexkant	Hexagon	Sechskant
23	Sexkant	Hexagon	Sechskant
24	Sexkant	Hexagon	Sechskant
25	Sexkant	Hexagon	Sechskant
26	Sexkant	Hexagon	Sechskant
27	Sexkant	Hexagon	Sechskant
28	Sexkant	Hexagon	Sechskant
29	Sexkant	Hexagon	Sechskant
30	Sexkant	Hexagon	Sechskant
32	Sexkant	Hexagon	Sechskant
32	Sexkant 65mm djup	Hexagon	Sechskant tjef
33	Sexkant	Hexagon	Sechskant
33	Sexkant 65mm djup	Hexagon long	Sechskant tief
34	Sexkant	Hexagon	Sechskant
36	Sexkant	Hexagon	Sechskant
38	Sexkant	Hexagon	Sechskant
39	Sexkant	Hexagon	Sechskant
41	Sexkant	Hexagon	Sechskant
46	Sexkant	Hexagon	Sechskant
PA 99	Mellanstycke 1" x 1"	Adapter 1" x 1"	Zwischenstück 1" x 1"
PA 92	Mellanstycke 1" x 3/4"	Adapter 1" x 3/4"	Zwischenstück 1" x 3/4"

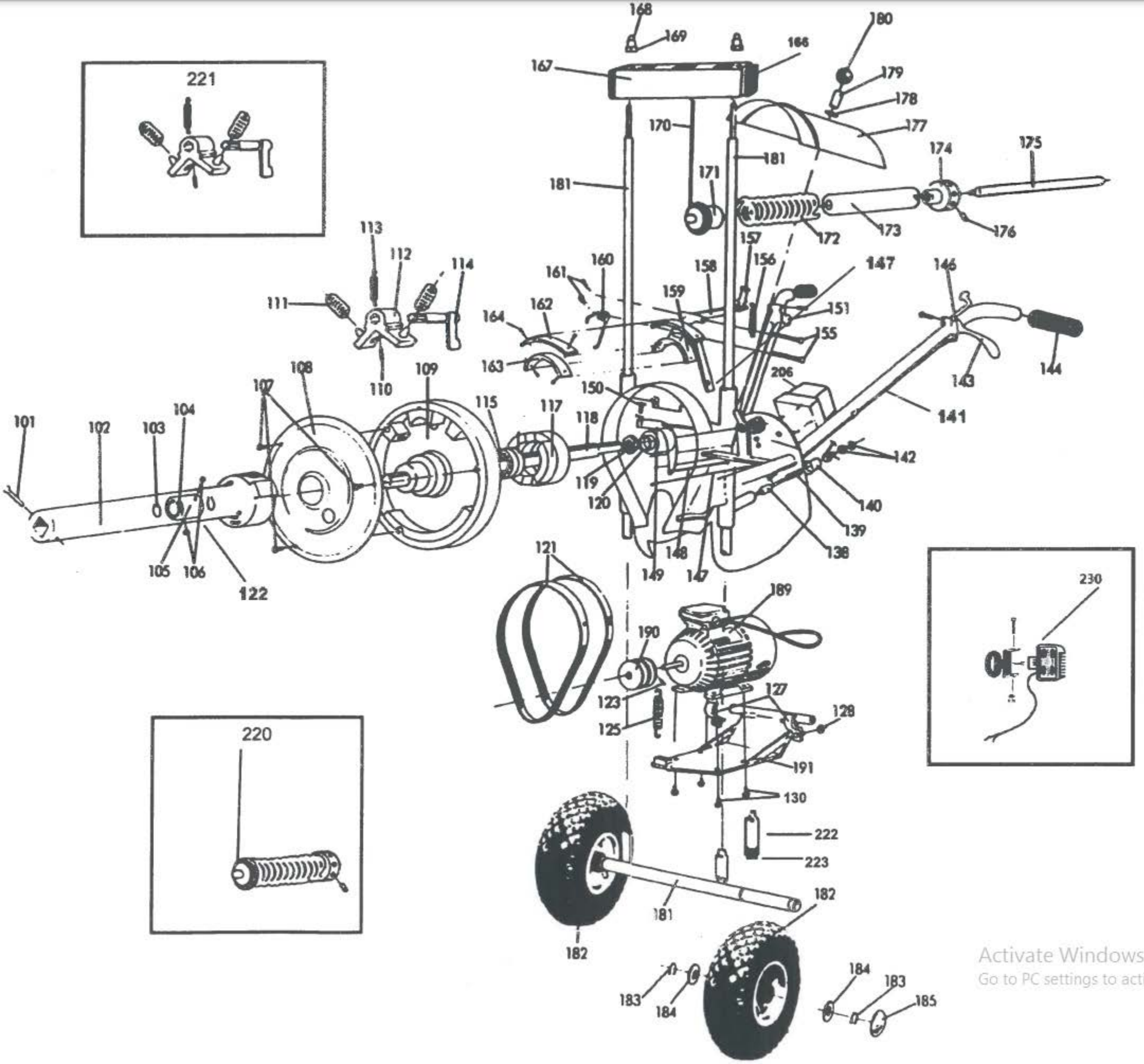

Nr	Namn	Name	Nahme
101	Skruv M8 x 50	Screw M8 x 50	Schraube M8 x 50
102	Hylsnyckelrör Ink.101+106	Socket spanner sleeve	Hülsenschlüsselrohr
103	Låsring	Locking ring	Sicherungsring
104	Kullager 6005-2Z	Ballbearing 6005	Kugellager 6005
105	Kullager + hållare	Ballbearing + holder	Kugellager + halterung
106	Bult M8 x 12	Bolt M8 x 12	Schraube M8 x 12
107	Bult M8 x 16	Bolt M8 x 16	Schraube M8 x 16
108	Runt Lock Ink.107	Cover	Schwungraddeckel
109	Svängjul (107-117)	Flywheel (107-117)	Schwungrad 107-117
110	Skruv S6SS M8x16	Screw S6SS M8 x 16	Schraube M8 x 16
111	Fjäder till slaghake	Spring for impact hook	Feder
112	Slaghake	Impact hook	Schlagwinkel
113	Fjäder till krok	Spring for hook	Feder
114	Krok Ink. 113	Hook	Winkelhebel
115	Kullager 6205/2RS1	Ball bearing 6205	Kugellager 6205
117	Bromsskiva stål	Brake disc	Bremsscheibe
118	Axel till 102	Shaft for 102	Welle für 102
119	Mutter M16	Nut M16	Mutter M16
120	Låsbricka	Star washer 16 mm	Zahnscheibe 16 mm
121	Kilrem	Drive belt	Keilriemen
122	Trycklager 6005-2Z	Ballbearing 6005	Kugellager 6005
123	Låsskruv till 190	Locking screw	Gewindestift für 122
125	Fjäder till motorbrygga	Spring for motor bridge	Feder
127	Gångjärn	Ring	Scharnier
128	Mutter M8	Nut M8	Mutter M8
130	Bult M8 x 25	Bolt M8 x 25	Schraube M8 x 25
138	Nivåstopp	Level stop	Höhenanschlag
139	Fjäder till nivåstopp	Spring for level stop	Feder
141	Dragstång till nivåstopp	Pull rod for 138	Zugstange für 138
142	Mutter M6	Nut M6	Mutter M6
143	Handtag kort	Handle short	Handhebel kurz
144	Plasthandtag	Plastic handgrip	Handgriff kunststoff
146	Slagreglage	Stroke control	Schlagregler
147	Dragstång till underbroms	Pull rod for 159	Zugstange für 159
148	Dragstång till tryckarm	Pull rod for 149	Zugstange für 149
149	Tryckarm	Pressure arm	Druckhebel
150	Skruv M8 x 50	Screw M8 x 50	Schraube M8 x 50
151	Handtag långt	Handle long	Handhebel lang
152	Skruv M5 x 16	Screw M5 x 16	Schraube M5 x 16
155	Axel till broms	Axel for brake	Bremsbackenachse
156	Fjäder till överbroms	Spring for upper brake	Feder
157	Skruv M6 x 35	Screw m6 x 35	Schraube M6 x 35
158	Överbroms	Upper brake	Obere bremsse
159	Underbroms	Lower brake	Untere bremsse
160	Fjäder till underbroms	Spring for lower brake	Feder
161	Saxpinne	Split pin	Splint
162	Bromsband till 158	Brake band for 158	Bremsbelag für 158
163	Bromsband till 159 ink.164	Brake band for 159	Bremsbelag für 159
164	Nit	Rivet	Niete
166	Plugg till överbåge	Plug for 167	Stecker for 167
167	Överbåge ink 170+166	Upper frame member	Obere strebe
168	Hattmutter M10	Domed nut M10	Hutmutter M10
169	Mutter M10	Nut M10	Mutter M10
170	Hisswire	Lifting wire	Stahlseil
171	Hissnäcka	Lifting pulley	Aufzugschnecke
172	Hissfjäder	Lifting spring	Aufzugfeder
173	Mellanrör	Carrier	Zwischenrohr
174	Bakstycke	Rear piece	Spannstück
175	Hissaxel	Lifting axle	Lifting axle
176	Låspinne	Locking pin	Verriegelungsstift

Nr	Namn	Name	Nahme
177	Overlock	Cover	Abdeckung
178	Bricka	Washer	Scheibe
179	Rör	Tube	Rohr
180	Kula M10	Knob M10	Griffkugel M10
181	Hjulställning	Wheel setting	Radgestell
182	Hjul ink.183-185	Wheel	Rad
183	Låsring	Locking ring	Klemmring
184	Bricka	Washer	Scheibe
185	Navkapsel	Hub cap	Radkappe
189	Motor 1,1 KW	Motor 1,1 KW	Motor 1,1 KW
190	Remskiva till 189	Pulley	Riemenscheibe
191	Motorbrygga	Bridge	Motorbrücke
206	Startbox	Startbox	Startbox
206-01	Brygga kontaktor	Contactora connector 400V	Schützstecker 400V
206-02	Kontaktör 400V	Contactora 400V	Schütz 400V
206-03	Kabelskydd	Cabel protection	Kabelschutz
208	Skalmskydd	Shaft protection	Welleschutz
209B	Knapp till starbox	Button for startbox	Knopf für startbox
220	Hiss kompl. 170-176	Complete lift 170-176	Füllen lift 170-176
221	Slagmekanism komplett 110-114	Impact mechanism complete 110-114	Füllen schlagwerk 110-114
222	Ben (tillval)	Stand (complement)	Beine (ergänzung)
223	Ben plugg	Stand plug	Beine Stecker
230	Belysningsatts	LED Light	LED Lampe