



AF1 PUMP MODEL 1050

AIR OPERATED TRANSFER PUMP

Technical Data

Ratio	1:1.33
Air Pressure Regulator	7 bar max.
Inlet	1/4" BSP
Maximum Air Pressure	7 bar
Minimum Air Pressure	2 bar
Air Consumption (ISO 68 @ 10 ltrs/min)	125 ltr/min
Exhaust	Double Baffled
Maximum Sound Level @ 1m	74 dB

Output Data

approx 250 mls/stroke when fully primed

Hydraulic Oils (ISO 32)	0-20 ltr/min
Lubrication Oils (ISO 68)	0-15 ltr/min
Gear Oils (ISO 220)	0-10 ltr/min
AdBlue	0-28 ltr/min
Water	0-28 ltr/min

Minimum Operating Temperature

It is recommended that the pump is not used below 2°C because ice formation may cause the regulator to malfunction.

Operating Instructions

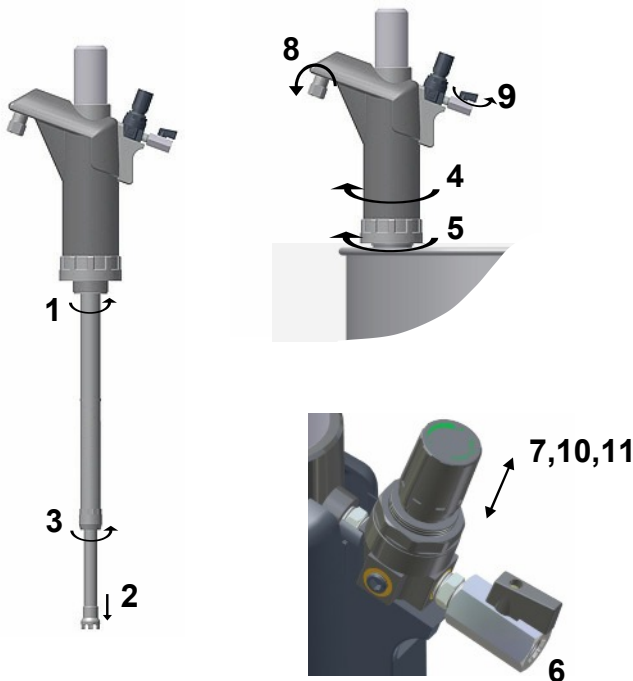

- 1) Screw uptake pipe into pump.
- 2) Extend uptake pipe to required length.
- 3) Fully tighten locking collar.
- 4) Screw pump into drum, taking care not to damage the plastic thread.
- 5) Fully screw down locking ring to secure pump in desired position.
- 6) Securely connect air line to pump inlet - 1/4" BSP.
- 7) Pull up adjusting knob on top of the regulator to enable adjustment.
- 8) Open outlet on/off tap nozzle.
- 9) Open air inlet on/off tap to discharge into a suitable container.
- 10) Adjust air pressure, by rotating knob at top of the regulator, until a smooth flow is achieved.
- 11) Push in the knob on the regulator to lock setting.
- 12) Close air inlet on/off tap to stop flow.

AF1 Safety in Operation

- 1) Removal of Regulator is not recommended and will invalidate warranty.
- 2) Do not attempt to dismantle Pump. Return to supplier if problems occur during correct operation. Tampering with the unit will invalidate warranty.
- 3) When using Optional Hose Kit always fit the Hose Bracket to the pump and ensure that the hose is inserted through the bracket grommet. Otherwise the pump may be damaged.
- 4) When not in use ALWAYS close air inlet using on/off tap as shown in instruction 12

Caution

The air regulator fitted to this product is designed for fluid control by regulating the pressure within the pump from a service air line pressure of 7 bar (100 p.s.i.) maximum. It is strongly recommended that an air line pressure greater than 7 bar (100 p.s.i.) should not be used.

Analysing & Rectifying Problems

Problem; The air piston does not operate.

Solution; The air pressure is too low. The minimum recommended air pressure is 2 bar (30 p.s.i.)

Problem; The air piston stalls.

Solution; At very low pressure this can occur and is normal.

a) Close and re-open the air inlet on/off tap.

b) Air piston may be frozen; see below.

c) Should stalling regularly occur, then re-adjust the regulator to increase air pressure.

Problem; Frost on air cylinder and air piston stalled.

Solution; In instances of prolonged pumping (usually when operating with hose kit) the air piston may freeze due to excess water in the air line supply.

Should this stall the pump then;

a) Close the air inlet on/off tap for a few minutes to allow the pump to thaw.

b) Fit a Filter or Filter/Lubricator to reduce water content in air supply to the pump.

ERNEST H. HILL LIMITED

LONGACRE WAY - HOLBROOK - SHEFFIELD S20 3FS - ENGLAND

Telephone; +44 (0) 114 248 4882

www.hillpumps.com

sales@hillpumps.com

05R35009