

## Warning

- Always ensure the threaded force screw of the tool is lubricated with suitable high load bearing grease and the thread is clean and free from debris.
- We recommend the use of molybdenum Disulphide grease, black grease or CV joint grease).
- Use of power tools for tightening the force screw will void the warranty.
- Always read and follow the manufacturers instructions
- Always wear gloves, safety goggles and safety boots
- Always tighten components to the manufacturers recommended torque settings
- Cleanliness is essential, any dirt or debris left within the hub housing could prevent the bearing from seating properly and cause premature failure.
- Always clean the area of the back of the hub prior to removal of the bearing to prevent dirt and debris from damaging the housing and jamming the puller bush/ force screw thread.
- The kit utilises an open force screw bearing design to allow ease of cleaning. Ensure the bearing is kept clean and free from dirt and debris. Lubricate with light oil.
- Use of this kit requires the partial dismantling of the vehicles braking system and drive shafts, always refer to the manufacturers instructions.
- The Tool Connection cannot be held responsible for any damage or injury to property or person how so ever caused.



**Safety First. Be Protected.**

## Guarantee

If this product fails through faulty materials or workmanship, contact our service department direct on: **+44 (0) 1926 818186**. Normal wear and tear are excluded as are consumable items and abuse.



Distributed by The Tool Connection Ltd

Kineton Road, Southam, Warwickshire CV47 0DR  
T +44 (0) 1926 815000 F +44 (0) 1926 815888  
info@toolconnection.co.uk [www.toolconnection.co.uk](http://www.toolconnection.co.uk)



[www.lasertools.co.uk](http://www.lasertools.co.uk)

5473

# LASER®

## GEN 2 Wheel Bearing Kit VAG 72mm

### Instructions

The extraction adaptor (572-6} for GEN2 bearing kits has been redesigned to allow the extraction of the relevant bearings without removing the ABS sensor.



- Generation II style wheel bearings are a wheel bearing and drive flange that cannot be separated.
- By using clamshells and force plate the tool ensures the loads of insertion are taken only on the outer race of the bearing.
- Replacement bar available - **Part No. 0454**
- Always grease threaded bar.
- Always check bearing size before buying the kit.



[www.lasertools.co.uk](http://www.lasertools.co.uk)

## Wheel Bearing | Hub Remover | Installer | VAG

Generation 2 style wheel bearings are a wheel bearing and drive flange assembly that cannot be separated. Should this type of bearing need replacing it has to be removed complete and a new unit installed complete with a new drive flange.

In order to ensure that the new bearings are not over loaded during installation it is important the correct tools are used to fit the bearing/drive flange assemblies. By using clamshells and force plate the tool ensures the loads of insertion are taken only on the outer race of the bearing.

Bearing Size	Clamshell Removal	Clamshell Replace	Bush Removal	Bush Replace
72mm	572C	C572	572-6	572-5

## Applications

For fitting GEN 2 bearings of 72mm diameter bearings:

Make	Model	Spec	Wheel	Year	Size	Spare Bar
Audi	A2	with PAS	Front	2000-	72mm	0454
Seat	Ibiza	with PAS	Front	2002-	72mm	0454
Skoda	Fabia	with PAS	Front	2000-	72mm	0454
Skoda	Roomster	with PAS	Front		72mm	0454
Volkswagen	Fox	with PAS	Front	2005-	72mm	0454
Volkswagen	Polo	with PAS	Front	2002-	72mm	0454

## Instructions | Fitting

- Use clamshells and puller bush for fitting.
- Ensure the load pins are correctly located in the holes in the force plate and through the drive flange.

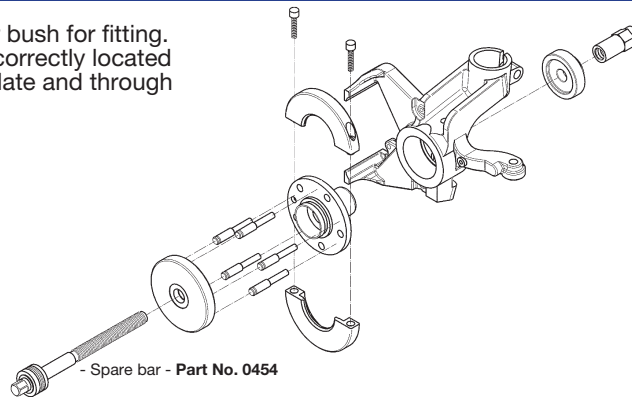

## Instructions | Removal

- Use clamshells and puller bush for bearing removal.
- Ensure the load pins are correctly located in the holes in the force plate and through the drive flange.

