

5784

LASER[®]

GEN 2 Wheel Bearing Kit Ford | 82mm

Instructions

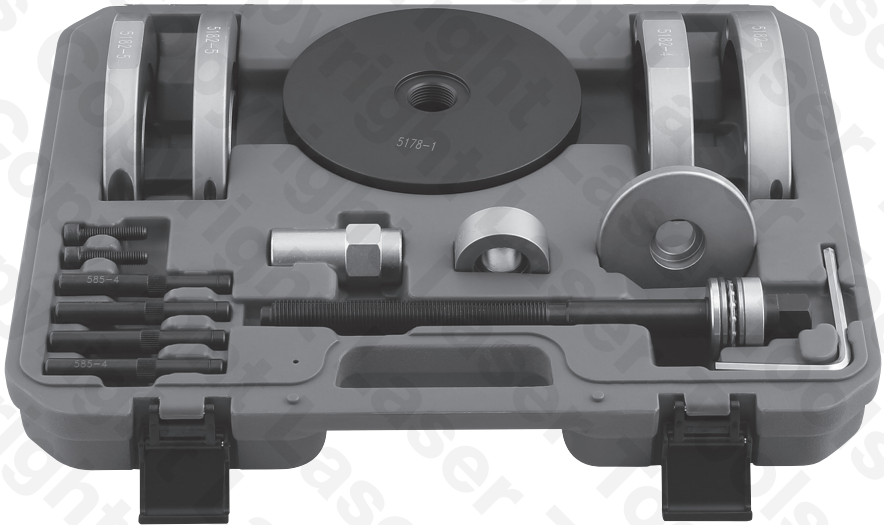

- Generation II style wheel bearings are a wheel bearing and drive flange that cannot be separated.
- By using clamshells and force plate the tool ensures the loads of insertion are taken only on the outer race of the bearing.
- Always check size of bearing before purchase.
- Always grease the threaded bar.
- Replacement bar available.



Applications

Make	Model	Year
Ford	Focus Mk II 2.5 RS	2007<
	RS 500	2007<
	Mondeo Mk IV	2007<
	Galaxy	2006<
	S-Max	2006<
Land Rover	Freelander II	2006<
Volvo	S80/V70/XC60/XC70	2006<

Components

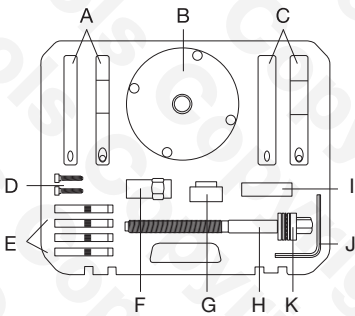

Ref	Description	Part No.
A	Insertion Clamshells	5182-5
B	Force Plate	5178-1
C	Removal Clamshells	5182-4
D	Clamshell Securing Screws	
E	Force Pins	585-4
F	Force Nut*	Laser 0108
G	Extraction Adaptor	5182-3
H	Main Force Screw*	Laser 0454
I	Insertion Adaptor	5182-6
J	Hex Key (6mm)	
K	Thrust Bearing*	Laser 0662

*Consumable

Instructions | Removal

The kit is designed to remove and replace the bearing/flange in situ on the vehicle. Refer to manufacturer's documentation for the correct procedure.

- Remove the brake caliper and disc. Remove the driveshaft.
- Clean the area at the back of the hub prior to removal of the bearing to prevent dirt and debris jamming the force screw, force nut and adaptor.
- Assemble the removal clamshells (C) to the bearing/flange; refer to diagram (Fig 1), secure with set screws (D) supplied.
- Assemble the four force pins (E) to the force plate (B). The rubber O-ring on the force pin will secure it in the force plate socket.
- Offer up the force plate/pin assembly to the clamshells, and fit the main force screw through the force plate/pin assembly.
- From behind, fit the extraction adaptor (G) over the end of the force screw. Collar-end in towards force screw - refer to Fig 1. Take care to line up cut outs with the ABS sensor.
- Secure the assembled tool with the force screw nut (F). Long threaded end of force screw nut in towards force screw - refer to Fig 1.
- Lubricate the force screw threads with black molybdenum disulphide grease. This must be done every time the tool is used.
- To withdraw the bearing/flange, hold the force nut (F) steady with a 30mm spanner while turning the force screw with a 22mm socket on a breaker-bar or long ratchet handle. (Do not use air tools.)

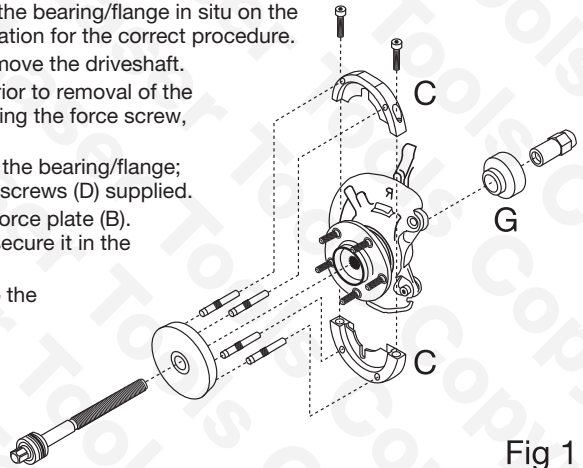

Fig 1

Instructions | Fitting a New Bearing/Flange Assembly

Important: Before fitting the new bearing/flange assembly again clean the area at the back of the hub, and around the hub housing. Any dirt or debris left within the hub housing could prevent the bearing from seating properly and cause premature failure.

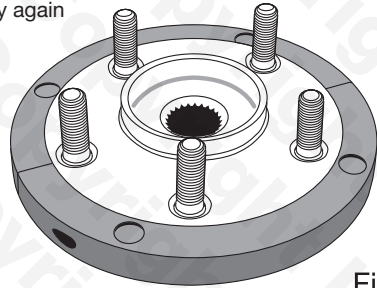

Fig 2

- Refer to Fig 2: Assemble insertion clamshells (A) onto new bearing/flange and secure with set screws (D) supplied.
- Assemble the four force pins (E) to the force plate (B). The rubber O-ring on the force pin will secure it in the force plate socket.

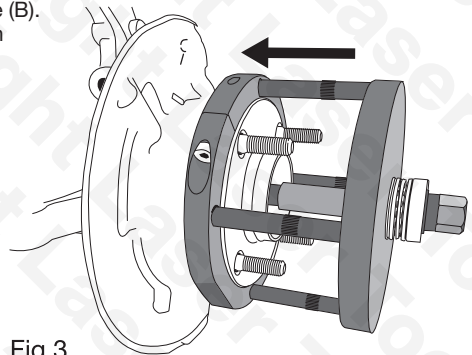

Fig 3

- Refer to Fig 3: Offer up the force plate/pin assembly to the clamshells, and fit the main force screw through the force plate/pin assembly.
- From behind, fit the insertion adaptor (I) over the end of the force screw so that it sits on the outer edge at the rear of the hub carrier. Take care to line up cut outs with the ABS sensor.
- Secure the assembled tool with the force screw nut (F). Long threaded end of force screw nut in towards force screw - refer to Fig 1.
- Lubricate the force screw threads with black molybdenum disulphide grease. This must be done every time the tool is used.
- To push in the new bearing/flange, hold the force nut (F) steady with a 30mm spanner while turning the force screw with a 22mm socket on a breaker-bar or long ratchet handle. (Do not use air tools.)
- Turn force screw until bearing/flange is fully home. If fitted, ensure that the tangs of the barbed retaining ring (K) are correctly seated in the retaining groove. See Fig 4.

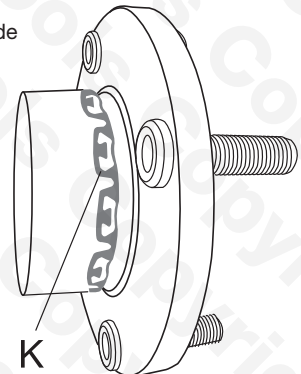

Fig 4

Warning

- Always ensure the threaded force screw of the tool is lubricated with suitable high load bearing grease and the thread is clean and free from debris. (We recommend the use of molybdenum Disulphide grease, black grease or CV joint grease)
- Use of power tools for tightening the force screw will void the warranty
- Always read and follow the manufacturers instructions
- Always wear gloves, safety goggles and safety boots
- Always tighten components to the manufacturers recommended torque settings
- Cleanliness is essential, any dirt or debris left within the hub housing could prevent the bearing from seating properly and cause premature failure.
- Always clean the area of the back of the hub prior to removal of the bearing to prevent dirt and debris from damaging the housing and jamming the puller bush/force screw thread.
- The kit utilises an open force screw bearing design to allow ease of cleaning. Ensure the bearing is kept clean and free from dirt and debris. Lubricate with light oil.
- Use of this kit requires the partial dismantling of the vehicles braking system and drive shafts, always refer to the manufacturers instructions.
- The Tool Connection cannot be held responsible for any damage or injury to property or person how so ever caused.



Safety First. Be Protected.

Guarantee

If this product fails through faulty materials or workmanship, contact our service department direct on: **+44 (0) 1926 818186**. Normal wear and tear are excluded as are consumable items and abuse.

 **TOOL
CONNECTION**
The Complete Connection

Distributed by The Tool Connection Ltd

Kineton Road, Southam, Warwickshire CV47 0DR
T +44 (0) 1926 815000 F +44 (0) 1926 815888
info@toolconnection.co.uk www.toolconnection.co.uk



Related K-Type Numbers

2862	7021	19439	23152	30470	33379	100384	113272
2879	9714	19440	23153	30837	33380	100393	113273
2881	9715	19441	23154	31406	33381	100394	113274
5060	9717	19442	23155	32118	33382	100402	113276
5086	9733	19443	23156	32119	33383	100518	113278
5136	9734	19444	23840	32120	33384	100519	113280
5137	9735	19708	24436	32387	33385	100520	113281
5152	9737	19714	24437	32388	33494	100522	113283
5575	9854	19753	24438	32389	33800	100528	113284
5614	10064	19754	24439	32685	33801	100896	113285
6047	10248	19755	24450	32693	33802	101020	113286
6051	10249	19756	24451	32699	33815	105580	113289
6066	10250	19757	24452	32701	33816	106317	113291
6067	10274	22506	24453	32705	33817	106318	113294
6087	10275	22507	24454	32849	51930	107410	114198
6124	10277	22508	24455	32850	54925	107411	114200
6151	10278	22509	24456	32851	55138	107412	115626
6154	10282	22510	24457	32852	57041	107414	116225
6158	10289	22511	24458	32853	57428	107415	116593
6168	10290	22512	24459	32854	57429	107460	116595
6274	10292	22513	24460	32855	57495	107461	117368
6278	10294	22514	24461	32856	57496	107466	117791
6279	10295	22515	24462	32857	58950	107467	117792
6802	10343	22516	24463	32910	59028	107468	118986
6803	11508	22517	24464	33347	59385	107469	119086
6915	12347	22518	27154	33348	59494	108270	119110
6918	12572	22519	27620	33349	59495	109981	119578
6921	12575	22520	27622	33350	100283	109982	120516
6932	12693	22521	27625	33351	100284	109983	120524
6938	12730	22522	27626	33352	100369	113260	120525
6939	12731	22523	28145	33354	100372	113262	120851
6951	12732	23049	28228	33355	100376	113263	126957
6979	14645	23100	28229	33373	100377	113265	
6981	15945	23146	28230	33374	100378	113266	
7002	19336	23147	28571	33375	100379	113267	
7015	19337	23148	30329	33376	100380	113269	
7019	19437	23150	30330	33377	100381	113270	
7020	19438	23151	30331	33378	100383	113271	