

SI-2033

Cut Off Grinder

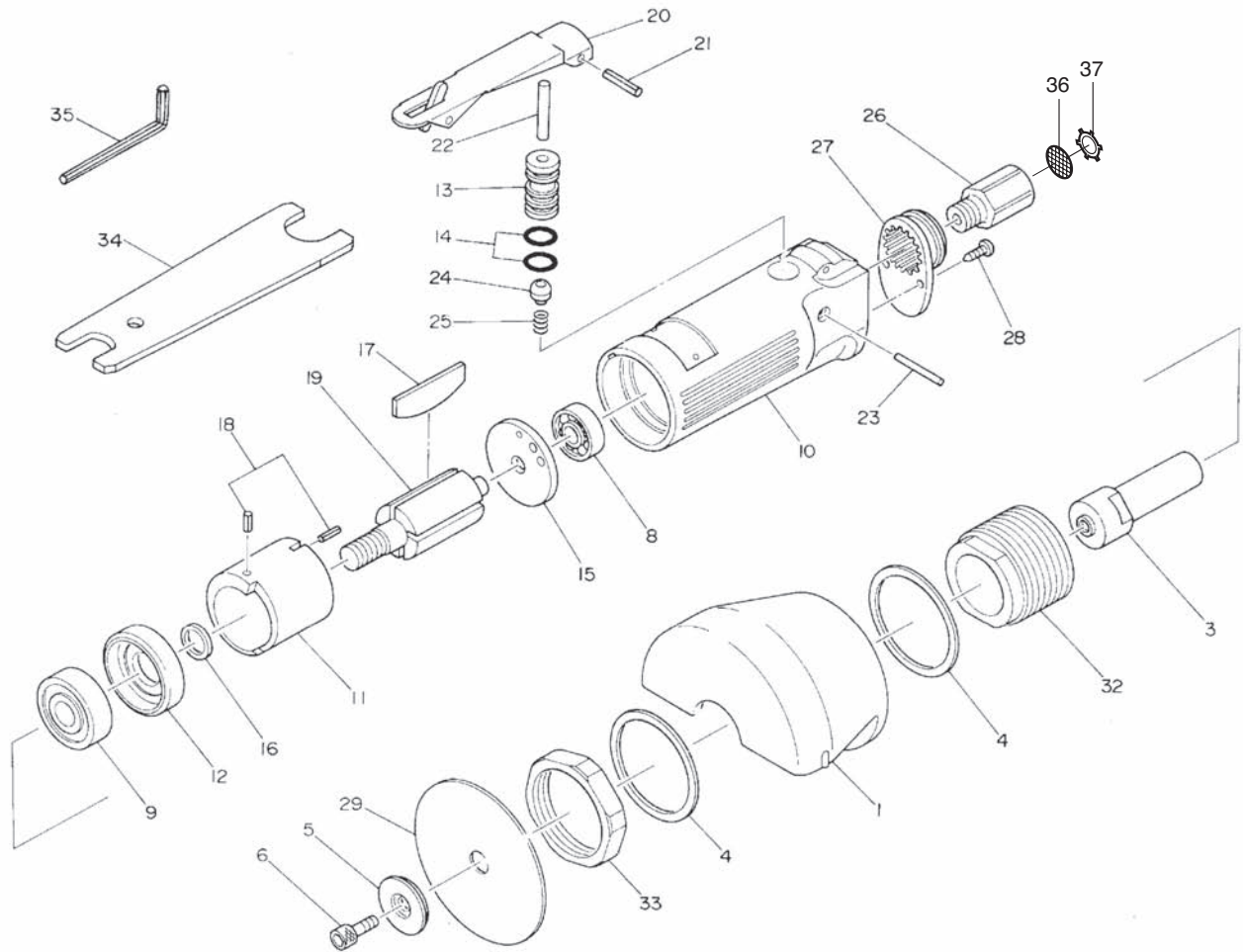

Ref. No.	Parts No.	Description	Q'ty	Ref. No.	Parts No.	Description	Q'ty
1	175-1	Wheel Guard	1	20	350-2L	Throttle Lever	1
3	175-3	Spindle	1	21	30-24	Roll Pin (3-24mm)	1
4	175-4	Wheel Washer	2	22	190-33	Valve Pin	1
5	621-5	Spacer	1	23	200-31	Pin	1
6	Z-1/420127	Cap Screw	1	24	300-10	Valve	1
8	608-ZZ	Ball Bearing	1	25	670-49	Valve Spring	1
9	6201-ZZ	Ball Bearing	1	26	985-10	Inlet Bushing	1
10	175-10	Motor Housing	1	27	120-11	Deflector	1
11	170-12	Cylinder	1	28	JBM30-80	Screw	2
12	170-3	Front Plate	1	29	175-29	Cut Disc	1
13	175-13	Valve Bushing	1	32	175-2	Lock Ring	1
14	P-10	O-Ring	2	33	175-7	Wheel Nut	1
15	175-14	Rear Plate	1	34	350-28	Spanner Wrench (14x19mm)	1
16	170-9	Spacer	1	35	WRA-3/16	3/16" Allen Wrench	1
17	170-5	Rotor Blade	4	36	680-28A	Screen	1
18	25-5	Roll Pin (2.5-5mm)	2	37	CRTW-12	Retainer	1
19	175-18	Rotor	1				