

ITEM NO.	QTY.	PART NUMBER	DESCRIPTION
1	1	M-AXP-1000	1 1/8" X 70-Tooth Pulley
2	1	M-AX-2000-01	Differential
3	1	M-AXB-1000-1	63mm x 41mm x 20mm Bearing
4	1	M-AXB-1000-2	82mm x 54mm x 20mm Bearing
5	1	M - A X - 2 0 0 0 - 0 7	Differential Cover
6	1	M - A X - 2 0 0 0 - 2 3	35 x 608mm Drive Shaft
7	1	M - A X - 2 0 0 0 - 2 4	35 x 432mm Drive Shaft
8	1	M-AX-2000-11	Pulley Housing
9	1	M-AX-2000-12	Pulley Housing
10	2	M-AX-2000-10	Shaft Bearing Seals
11	2	M - A X - 2 0 0 0 - 0 8	Mounting Cling Block Threaded
12	2	M - A X - 2 0 0 0 - 0 9	Mounting Cling Block
13	1	M - A X - 2 0 0 0 - 0 6 L	Drive Shaft Sleeve (Short)
14	1	M - A X - 2 0 0 0 - 0 6 R	Drive Shaft Sleeve (Long)
15	2	M-BC-1007	2 Piston Brake Caliper Bracket
16	2	M-AX-2000-15	60mm x 30mm x 37mm Bearing
17	2	M - A X - 2 0 0 0 - 2 5	42mm x 32 mm Spacer
18	2	M - A X - 2 0 0 0 - 0 4	Wheel Hub
19	2	M-RT-4050	Trike Brake Rotor
20	2	M-BC-1005	2 Piston Brake Caliper
21	2	M - A X - 2 0 0 0 - 1 8	Lock Washer
22	2	M - A X - 2 0 0 0 - 2 1	Shaft Slotted Nut
23	6	---	3/8-16 X 1.25 Socket Head Bolt
24	6	---	3/8 Flat Washer
25	6	---	3/8-16 Lock Nut
26	16	---	M6 -1.0 X 16 Socket Head Bolt
27	10	---	M6 -1.0 X 30 Socket Head Bolt
28	22	---	M10 - 1.5 X 30 Socket Head Bolt
29	10	---	6mm Flat Washer
30	4	---	M10 Washer
31	2	---	M8 - 1.25 X 10 Set Screw
32	4	---	M10 - 1.5 Lock Nut
33	2	---	Cotter Pin
34	2	M-AXB-1002	Bearing Bolt-on seal
35	2	M-AXB-1003	Bearing Base seal
36	8	---	
37	4	---	
38	10	M-AX-2000ST	M12 X 1.5 Lug Bolt

Torque Value	Item #
15/17 Ft/Lbs. - 20/23 Nm	27, 28, 32
45/50 Ft/Lbs. - 61/68 Nm	24, 26, 29
85/90 Ft/Lbs. - 115/122 Nm	22, 38

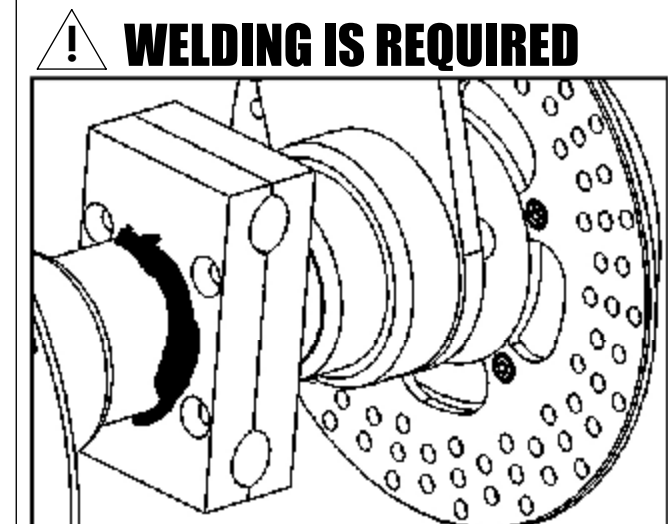

! WELDING IS REQUIRED

Before Welding: make sure the axle assembly is properly aligned with the transmission drive pulley, and the belt or chain clears the windows on housing, if the belt/chain does not clear the windows serious damage may occur to housing and may result serious injury to the rider.

After performing your side-to-side belt/chain alignment and rotational index of the belt/chain windows, place three 3/4" long welds around the axle (12, 4, & 8 o'clock position) on the left and right inner plates (as shown on illustration)

Legend:
 ◆ Apply 242 Blue Loctite
 ⊗ Not Included

DNA Specialty Inc. Property & Confidential
WARNING!!! The installation of this product should be done by a professional and certified motorcycle mechanic.
DNA SPECIALTY WILL NOT BE HELD LIABLE FOR ANY CONSEQUENTIAL OR INCIDENTAL DAMAGES RESULTING FROM IMPROPER INSTALLATION, MODIFICATION, OR ABUSE

Trike Rear Axles	TYPE	Part Number
1 1/2" X 70-Tooth	BELT	M-AX-2007
1 1/8" X 70-Tooth	BELT	M-AX-2000
51-Tooth 350 Chain	CHAIN	M-AX-2002

Pulley Replacement	Part Number
1 1/2" X 70-Tooth	M-AXP-1002

Brake Caliper Replacement Parts	Part Number
2 Piston Brake Pads	M-BC-1011
2 Piston Brake Caliper Rebuild Kit	M-BC-1024
Banjo Bolt	M-BB-1000
Bleeder Screw	M-BC-1001

BOLT PATTERNS: 5 X 4 1/2", 4 3/4", & 5"
STUD SIZE: M12 X 1.5

