

# Assembly Instructions

Parts and Tools list

NO.	Name	Qty	NO.	Name	Qty
1	Support Beam	1	11	M6*10 Screw	8
2	Foot Pad	4	12	Driveshaft	1set
3	Foot Margin	2	13	2.5mm Hex Spanner	1
4	M6*16 Screw	8	14	4mm Hex Spanner	1
5	Gasket 6	8	15	5mm Hex Spanner	1
6	Bracket	2	16	M6*12 Screw	4
7	M8*10 Screw	8	17	ST4.8*19 Screw	16
8	Handle	1	18	Rubber Cushion	10
9	Handle Fix	1	19	M6*16 Screw	4
10	Lifting System	1set			

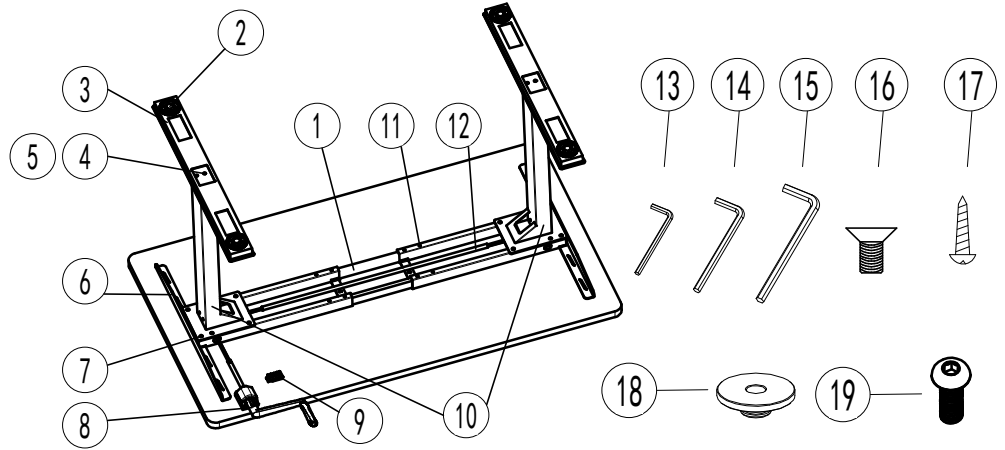

**1** Loosen the 4 screws of beam using 4MM hex spanner, adjust the beam to proper position to fit the desktop

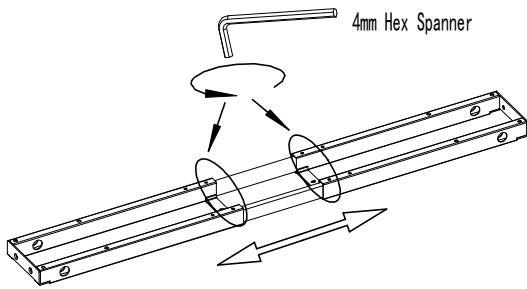

**2** Attach legs to the beam using 8 of M8\*10 screws

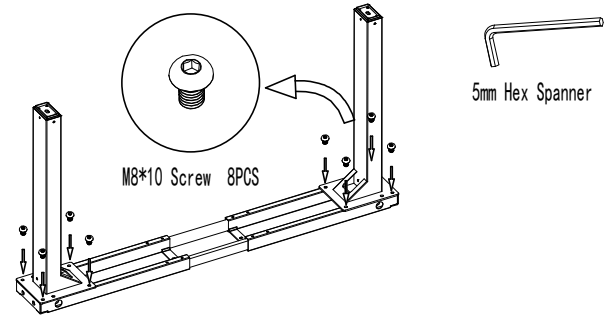

**3** Attach 2 feet to leg using 8 of M6\*16 screws and 8 of gaskets, attach the 4 of levelling foot pads to the feet

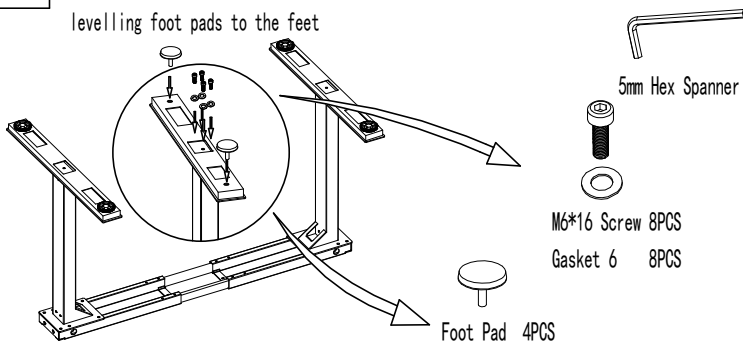

**4** Overturn frame and attach brackets to beam using 4 of M6\*12 screws, and then fit the rubber cushions to the brackets and beams

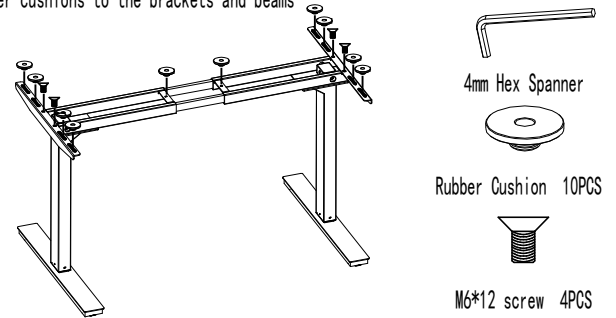

**5** Overturn frame, loosen the screws of transmission rod (both end) using 2.5mm hex spanner, insert the 2 hex rod to 2 legs, tighten screws

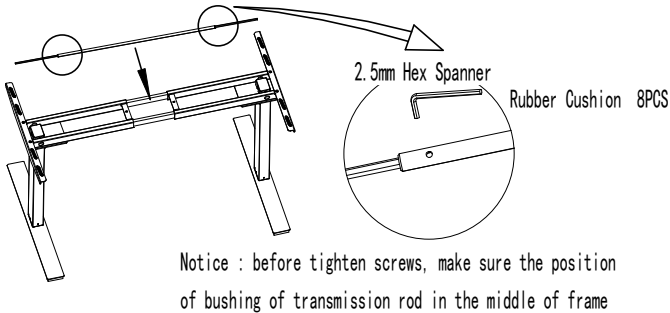

**6** Fix the handle as below shown

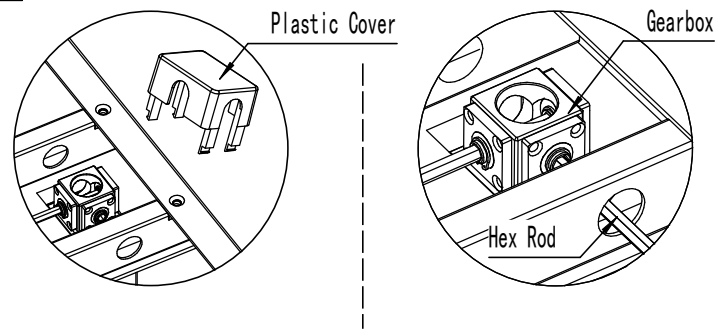

**7** Fit the frame to table using 10 of ST4.8 self-tapping screws, insert the hex rod to the gear box of leg, fit the handle to tabletop using 6 of ST4.8 self-tapping screws (you can use the self tapping screw or in case of inserts use the M6\*16 screw).

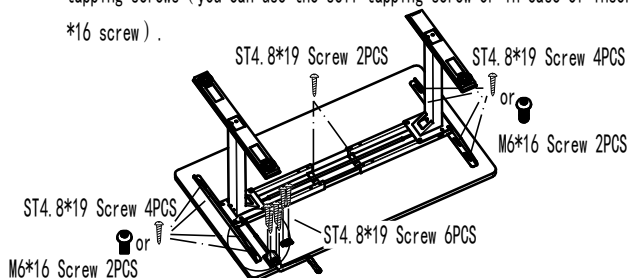

**8** Swing the handle clockwise, frame will move up, swing the handle anti clockwise, frame will move down

