

INNOTECH AIO-BKS



Instruction manual

DE – ACHTUNG: Die Verwendung des INNOTECH-Produkts ist erst zulässig, nachdem die Gebrauchsanleitung in der jeweiligen Landessprache vollständig gelesen und verstanden wurde.

EN – ATTENTION: Use of the INNOTECH product is only permitted after the instruction manual has been read and fully understood in the respective language.

IT – ATTENZIONE: L'utilizzo del prodotto INNOTECH è permesso solo previa lettura e comprensione dell'intero manuale di istruzioni nella lingua del relativo paese di utilizzo.

FR – ATTENTION : L'utilisation du produit INNOTECH n'est autorisée qu'après avoir entièrement lu et compris la notice d'utilisation dans la langue du pays concerné.

NL – ATTENTIE: Dit INNOTECH-product mag pas gebruikt worden nadat u de gebruikershandleiding in de taal van het betreffende land gelezen en begrepen hebt.

ES – ATENCIÓN: Se autorizará el uso de los productos INNOTECH una vez que se hayan leído y entendido las instrucciones de uso en el idioma del país.

PT – ATENÇÃO: O uso do produto INNOTECH apenas é permitido depois de ter lido e compreendido na totalidade as instruções de uso na respetiva língua nacional.

DK – GIV AGT: Du må først bruge et produkt fra Innotech, efter du har læst og forstået brugsvejledningen i fuldt omfang i dit lands sprog.

SV – O B S : Denna INNOTECH-produkt får inte användas förrän bruksanvisningen på respektive lands språk har lästs igenom och förstås.

CZ – POZOR: Práce s výrobkem INNOTECH je povolena teprve po kompletním přečtení a porozumění návodu k použití v jazyku daného státu.

PL – UWAGA: Produkty firmy INNOTECH mogą być używane dopiero po dokładnym zapoznaniu się z całą instrukcją obsługi w odczytym języku.

SL – POZOR: Uporaba izdelka INNOTECH je dovoljena šele po tem, ko ste navodila prebrali v celoti v ustreznem jeziku svoje dežele in jih tudi razumeli.

SK – POZOR: Produkt INNOTECH môžete používať až po prečítaní a porozumení celého návodu na použitie pre príslušnú krajinu.

HU – FIGYELEM: Az INNOTECH termékek használatát csak azt követően engedélyezett, hogy saját nyelvéen elolvasta és megértette a teljes használati utasítást.

TR – DİKKAT: INNOTECH ürününün kullanımına ancak ilgili ülkenin dilinde sunulmuş olan kullanım kılavuzunun tamamen okunmasından ve anlaşılmasından sonra izin verilir.

ZH – 注意: 只有在仔细阅读并完全理解了当地语言的使用说明后，才能使用 INNOTECH 公司的产品。



[2]	DESCRIPTION OF SYMBOLS	3
[3]	SAFETY INSTRUCTIONS	4
[4]	COMPONENTS/MATERIAL	6
[5]	PRODUCT SUITABILITY/APPROVAL	7
[6]	INSPECTION	8
[7]	WARRANTY	9
[8]	SIGNS & MARKINGS	10
[9]	DIMENSIONS	11
[10]	INSTALLATION SUBSTRUCTURE	12
[11]	FASTENING OPTIONS	12
[12]	BEAM SUPPORTING OPTIONS	13
[13]	INSTALLATION INSTRUCTION	14
[14]	INSTALLATION TOOLS	15
[15]	INSTALLATION	16
[16]	EXAMPLES OF USE	21
[17]	LOAD DIRECTIONS	22
[18]	WASTE DISPOSAL	22
[19]	ACCEPTANCE REPORT	23
[20]	FALL PREVENTION SYSTEM NOTICE	25
[21]	INSPECTION REPORT	26
[22]	DEVELOPMENT & SALES	28

Warnings / danger notices

For an IMMEDIATE danger, which could lead to severe injury or death.



For a POTENTIALLY dangerous situation, which could lead to severe injury or death.



For a POTENTIALLY dangerous situation, which could lead to injuries and property damage.



Wear protective gloves!



Wear protective glasses!

**Additional information/notice**

correct



incorrect



Follow the manufacturer's instructions / the respective user manuals.

The following safety instructions and the current state of the art must be taken into consideration.

3.1 GENERAL INFORMATION

- The fall protection system may be installed only by specialised / competent experts familiar with the fall protection system and in compliance with the current state of the art.
- The protective equipment may be used only by people who
 - are trained in the use of "personal protective equipment" (PPE).
 - are in good physical and mental health. Medical conditions such as cardiovascular problems, intake of medicines, consumption of alcohol, etc. negatively affect the safety of the user.
 - are familiar with the locally applicable safety regulations.
- During installation/use of the fall protection system, the respective accident prevention regulations (e.g. working on roofs) must be complied with.
- Understand and accept the options, restrictions and risks of the protective equipment.
- A plan must be available that specifies rescue procedures for all possible emergencies.
- Before starting work, ensure that no objects can fall to the ground from the work site. The area below the work site (pavement, etc.) must be kept clear.
- You should plan, install and use the anchorage point in such a way that no one can fall over the edge if the personal protective equipment (PPE) is used properly. (See planning documents on www.innotech.at).
- At the access of the roof fall protection system, you must document the positions of the anchorage devices by means of plans (e.g. top view of the roof).
- If following the certification of the fall protection system, structural changes are carried out in the immediate vicinity of the fall protection system, it must be ensured that these changes do not affect the security of the installed fall protection system! Where there is any doubt, consult a structural engineer or the manufacturer.
- After a fall and the resulting load, the use of the fall protection system must be stopped and it must be checked by a specialised expert (component parts, attachment to the substructure, etc.).
- Do not make any changes to the fall protection system.
- If used on sloping roofs, roof avalanches (ice, snow) must be avoided by means of suitable devices to intercept snow.

- If you provide the fall protection system to external contractors, their familiarity with this instruction manual must be confirmed in writing.
- If the equipment is sold in another country, the instruction manual must be provided in the respective national language!
- Comply with the customary national provisions for lightning protection.

3.2 FOR FITTERS: FOR SAFE INSTALLATION

- All stainless steel bolts must be greased with a suitable lubricant before installation (included: Weicon AntiSeize ASW 10000 or of same quality).
- Ensure that stainless steel does not get in any contact with swarf or steel tools, as this may lead to corrosion.
- Document the professional attachment of the fall protection system to the building structure with dowel logs and photos of each fitting situation.
- The fitters must ensure that the substructure is suitable for fastening the anchorage device. If in doubt, consult a structural engineer.
- The roof covering must be properly sealed in accordance with applicable guidelines.



If uncertainties arise during installation, it is imperative that you contact the manufacturer.

3.3 FOR USERS: FOR SAFE USE

- The minimum free space necessary under the edge is calculated as follows: Deformation of the anchorage device in the event of strain + manufacturer's specification of the personal protective equipment used including deflection of the cable + body height + 1m safety margin.
- Correct use of the individual elements including "personal protective equipment" must be ensured, because otherwise the safe functioning of the fall protection system is NOT guaranteed.
- Attachment to the fall protection system is always executed through the rotating anchorage eye with a carabiner and must be used with personal protective equipment in accordance with EN 361 (safety harness) and EN 363 (fall arrest system).
- **ATTENTION!** For horizontal use, only lanyards may be used that are suited for this purpose and have been tested for the respective edges (sharp edges, trapezoidal sheets, steel girders, concrete, etc.)
- Do NOT use fall protection systems if wind speeds exceed normal parameters.
- The fall protection systems must NOT be used by children and pregnant women.

4.1 INNOTECH „AIO-BKS-GP-01“

A)



B)

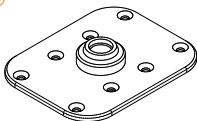

A) Installtion instructions

B) Base plate: stainless steel, quality A2

4.2 INNOTECH „AIO-BKS-AW-01“

A)



B)

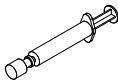

C)



D)

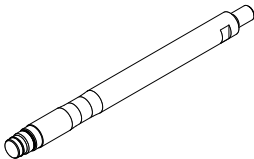

A) Instruction manual

B) Lubricant: Weicon AniSeize ASW10000

C) Lock nut M16: stainless steel, quality A2

D) Stop shaft: stainless steel, quality A2

INNOTECH „AIO-BKS“ has been

- developed as anchorage point for personal **safety for end-/corner points**. It was also developed as **intermediate bracket** (not included in delivery!) **Horizontal lifeline system according to EN 795:2012 TYPE C & CEN/TS 16415:2013** and
- as anchorage point for personal safety of 4 people (including 1 person for the provision of first aid) according to EN795:2012 TYPE A & CEN/TS 16415:2013 (EAP-SPAR-10-25) and is suitable for the following fall protection systems according to EN363:2008:
 - Restraint systems
 - Workplace positioning systems
 - Fall arrest systems
 - Rescue systems



DANGER TO LIFE from incorrect use.

- Use INNOTECH standard posts **ONLY** for personal safety.
- **NEVER** hang loads to INNOTECH standard posts that have not been approved in this instruction manual.



Comply with the manufacturer information for the personal protective equipment used.

INNOTECH "AIO-BKS" has been tested and certified according to **EN 795:2012 TYPE A & TYPE C** as well as **CEN/TS 16415:2013**

The notified authority participating in the type test:
IBS-Institute for Fire Protection and Safety Research,
Petzoldstraße 45, 4017 Linz/Österreich

6.1 TO BE CHECKED BEFORE EACH USE

Prior to each use, INNOTECH standard posts must be checked visually for any obvious defects.

**DANGER TO LIFE through damage to INNOTECH standard posts.**

- INNOTECH standard posts must be in faultless condition.
- INNOTECH standard posts must NO longer be used, if
 - damage or wear to its components are obvious,
 - other defects were observed (loose threaded connections, deformation, corrosion, wear, etc.),
 - strain has occurred due to a fall (exception: provision of first aid),
 - the product identification is illegible.

Check the intire fall protection systems's suitability for use by using the acceptance protocol and test log.



**If there are any doubts concerning the reliable operation of the fall protection system, it must NO LONGER be used and must be checked by an expert (written documentation).
If necessary, replace the product.**

6

INSPECTION

6.2 ANNUAL CHECKS

INNOTECH standard posts must be inspected at least once a year by a specially trained technician who is familiar with the fall protection system. The user's safety depends on the effectiveness and durability of the equipment.

Shorter intervals between inspections may be required, depending on the intensity of use and the environment (e.g. in corrosive atmosphere, etc.)

Document the verification by the specialist in the test log in the instruction manual and keep it with the instruction manual.



The inspection intervals are found in the test log.

7

WARRANTY

The warranty period for manufacturing defects on all components (under normal conditions of use) is 2 years from the date of purchase. The time limit is shortened through use in corrosive atmospheres.

If there is strain (a fall, weight of snow, etc.) the warranty claim is void for those components that have been designed to absorb energy, or that may possibly be deformed.



For system installation and for components planned and installed under the responsibility of specialised installation companies, INNOTECH assumes neither responsibility nor warranty in the case of improper installation.

8.1 INNOTECH „AIO-BKS-GP-01“

- A) Name or logo of the manufacturer/reseller: INNOTECH®
 B) Type designation: AIO-BKS-GP-01
 C) Sings stating that instruction in the manual must be followed: 
 D) Maximum number of people who can be secured: 4 (including 1 person for first-aid administration)
 E) Year of manufacture and manufacturer's serial number: YYYY-...-...
 F) Number of the applicable standard: EN 795:2012 TYPE A & C



8.2 INNOTECH „AIO-BKS-AW-01“

- A) Name or logo of the manufacturer/reseller: INNOTECH®
 B) Type designation: AIO-BKS-AW-01-300
 C) Sings stating that instruction in the manual must be followed: 
 D) Maximum number of people who can be secured: 4 (including 1 person for first-aid administration)
 E) Year of manufacture and manufacturer's serial number: YYYY-...-...
 F) Number of the applicable standard: EN 795:2012 TYPE A & C



[mm]

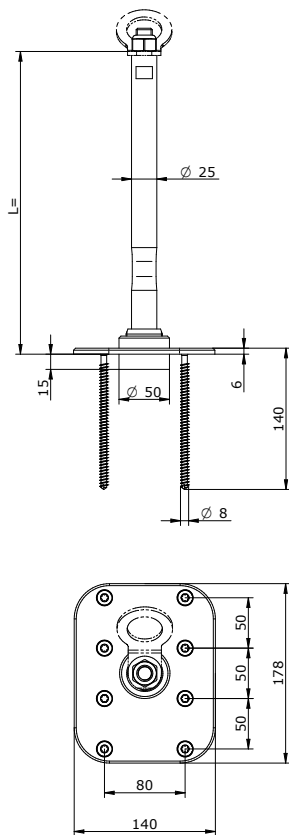

Standard length (L): 300 mm

10

INSTALLATION SUBSTRUCTURE

The basic prerequisite for professional / proper installation is a static load-bearing substructure:

- OSB board (max. boardthickness 30 mm) with wooden rafter (quality KVH S 10, max. rafter height 260 mm) (dimensions see image) and
- use of the original fasteners listed in this instruction manual.

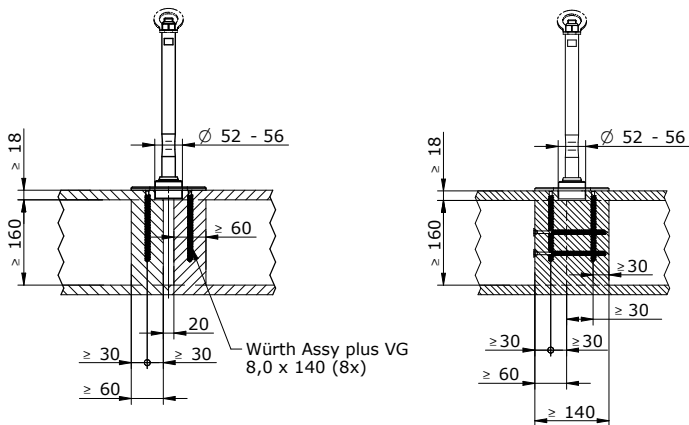

DANGER

DANGER TO LIFE as a result of installation on unsuitable substructure.

- Install INNOTECH standard posts on a static load bearing substructure. In case of doubt the installation substructure must be checked by a structural engineer or by the manufacturer.

11

FASTENING OPTIONS



Use the original fasteners:

Würth Assy plus VG 8,0 x 140 mm (INNOTECH BEF-207)

Nicht im Lieferumfang enthalten!

[mm]

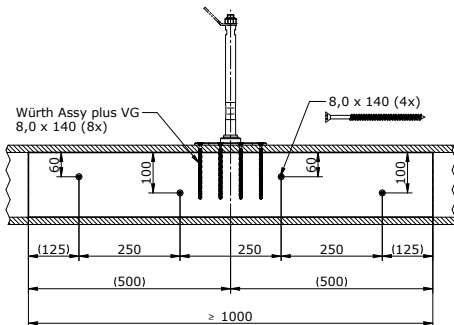
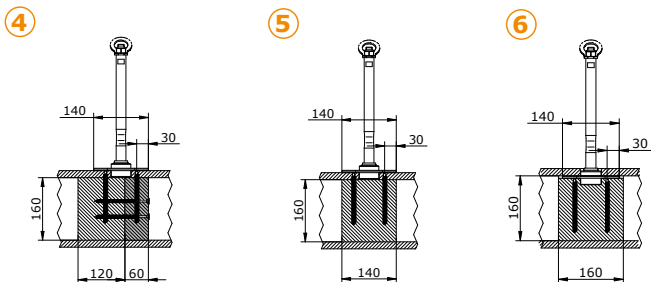
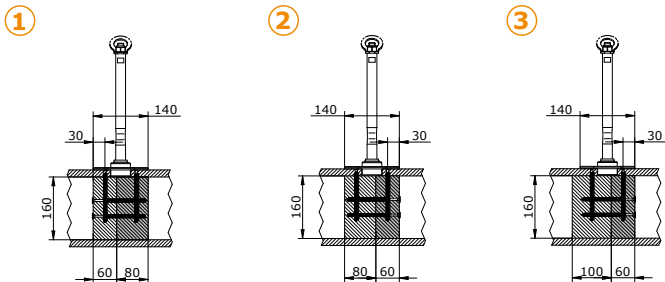

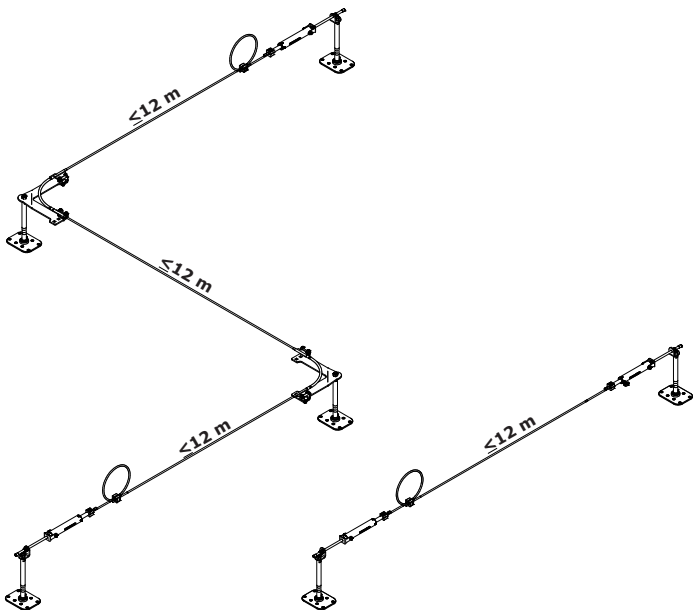
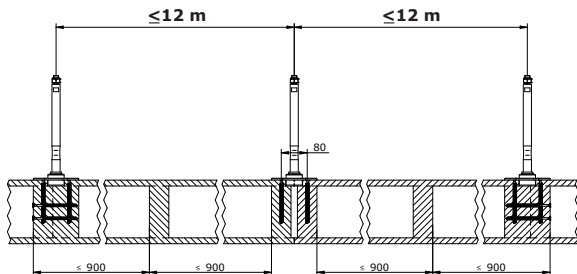

Mind the rafter distances.

[mm]

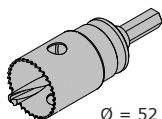
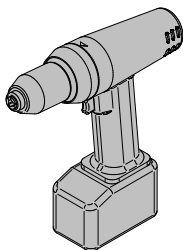
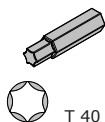
 $\varnothing = 52 - 56$ 

T 40

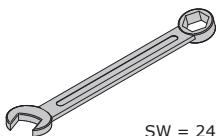

SW = 24

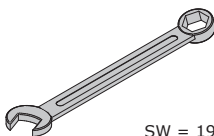

SW = 19 optional



DANGER TO LIFE IF NOT properly installed.

- Properly install INNOTECH standard posts as specified in the instruction manual.
- Die Randabstände zum Dachbahnende von min. 500 mm einhalten (Abbildung).

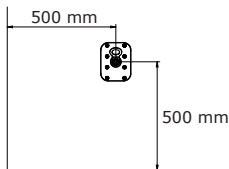

INJURIES DUE TO SHARP EDGES ON COMPONENTS.

- Wear gloves for installation.

15.1 INSTALLATION BASE PLATE ON THE SUBSTRUCTURE

1.

Drilling of the base plate.

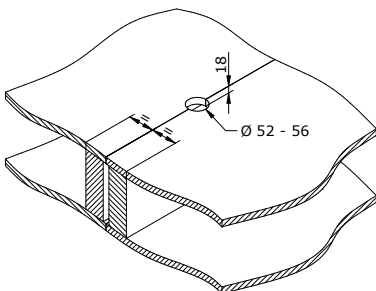

Borehole ONLY through OSB plate.

15 INSTALLATION

2.

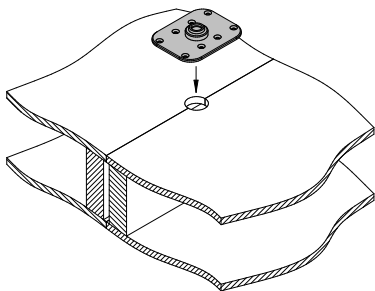

3.

Fix base plate with 8 fastening bolts (INNOTECH BEF-207).



T 40

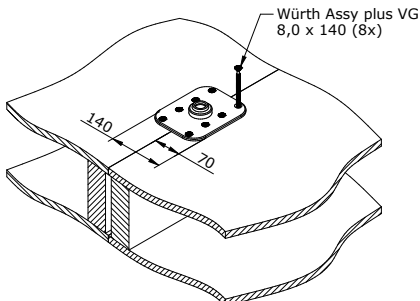

Hand tighten the fastening bolts.

15 INSTALLATION

15.2 INSTALLATION STOP SHAFT

1.



SW - 10

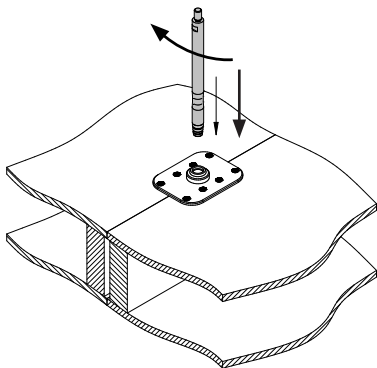

Hand tighten stop shaft until it clicks

15.3 INSTALLATION EAP-COMPONENTS

1.



SW - 10



SW - 24

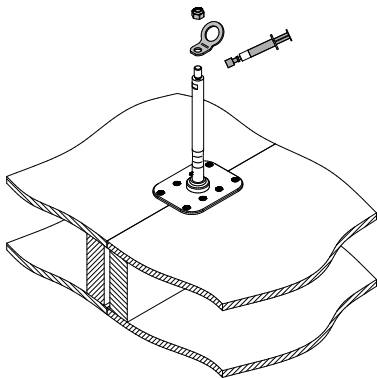

15 INSTALLATION

2.

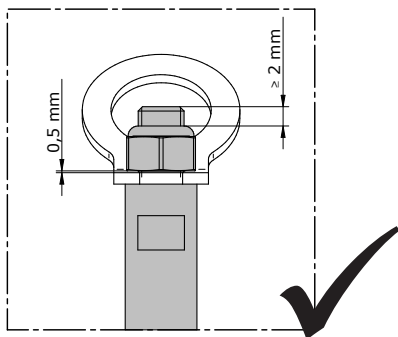

DONE

15.4 INSTALLATION AIO-COMPONENTS

1.

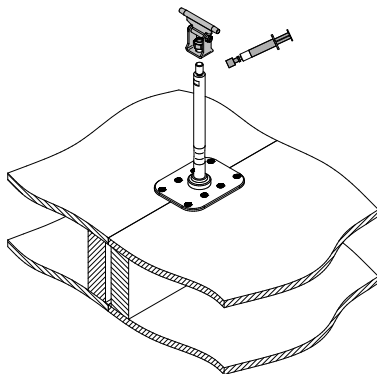

15 INSTALLATION

2.

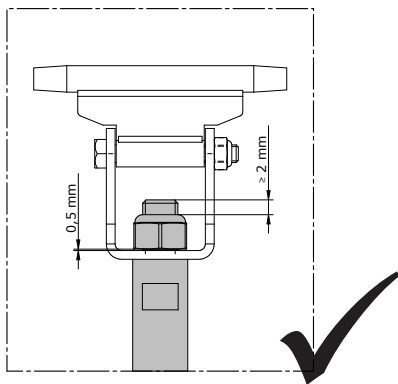

DONE

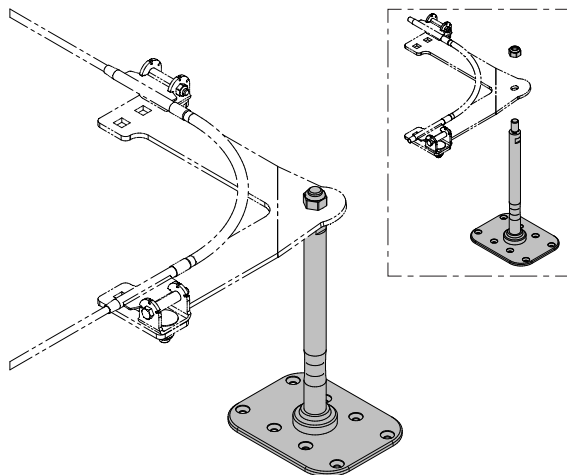
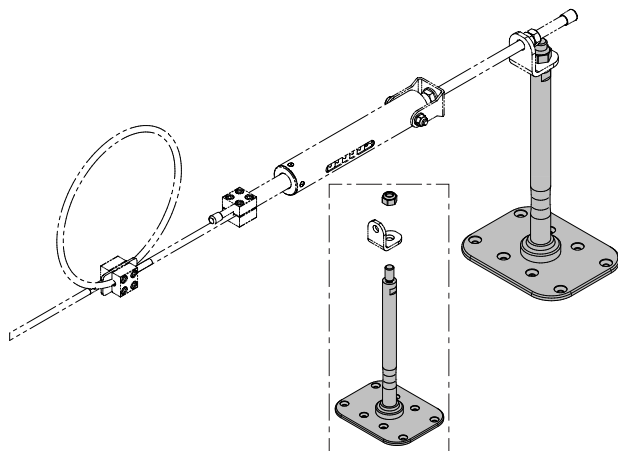

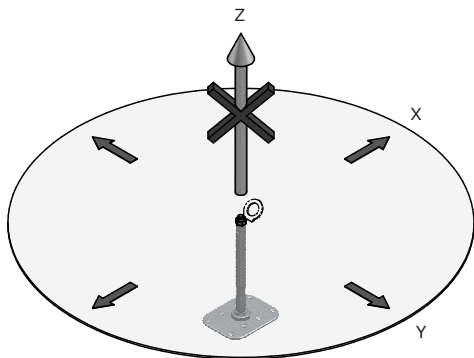

DANGER TO LIFE when used in UNAPPROVED load directions.

- Only use INNOTECH posts in the approved load directions.
- A work- / application load towards z-axis is NOT allowed.

Do not dispose of the fall protection system in the house waste.

As per national requirements, gather together the used parts and dispose of them environmentally correctly.

ACCEPTANCE LOG NO. _____ (PART 1/2)

A I O - B K S

ORDER NUMBER: _____

PROJECT: _____

CLIENT:

Specialist:



Company address:

CONTRACTOR:

Specialist:



Company address:

INSTALLATION: (please tick as appropriate!) **EAP** (single anchor points) **ANCHORAGE POINTS** of a horizontal lifeline system according to
EN 795:2012 TYPE C

Specialist:



Company address:

OPTIONAL: For set up of a horizontal lifeline system according to
EN 795:2012 TYPE C

INSTALLATION of the anchorage points by : _____

INSTALLATION of the lifeline system through:

ACCEPTANCE LOG NO. _____ (PART 2/2)

A I O - B K S

FASTENER & PHOTO DOCUMENTATION

PRODUCT: Item _____ Serial number: _____
(Type designation EAP/anchorage point)

Installation substructure: _____
(e.g. solid concrete, concrete quality: C20/25, wood rafter dimension, for sheet metal roofs: roof manufacturer, profile, material, sheet metal thickness, etc.)

Date:	Location:	Dowel type: BEF/Sticker?/ Designation	Setting depth: [mm]	Bohrer Ø: [mm]	Drill bit:	Photos: (storage location)
			mm	mm	Nm	
			mm	mm	Nm	

The installation company who signs warrants proper workmanship (edge spacing, inspection of the substructure, proper cleaning of bores, compliance with curing times and processing temperature, compliance with the dowel manufacturer's guidelines, etc.)
The client accepts the work performed by the contractor. The instruction manual, documentation of the anchorage points/photo documentation and test logs have been transferred to the client (building owner) and have been made available to the user. Near the system access to the fall protection system, the positions of the anchorages must be documented by the building owner through plans (e.g. top view of the roof).

The expert fitter familiar with the fall protection system confirms that the installation tasks have been executed properly, according to the state of the technology and according to the manufacturer's instruction manual. The technical safety reliability is confirmed by the installation company.

Handover of: (e.g. Personal protective equipment PPE, fall arrest devices HSG, storage cabinet, etc.)

Item _____ Item _____ Item _____ Item _____

Integrated in the existing lightning protection system? YES NEIN

Comments: _____

Name: _____

Client

Inspection: Contractor (expert who is familiar with the fall protection system)

Date, company stamp, signature

Date, company stamp, signature

INFORMATION FOR THE EXISTING FALL PROTECTION SYSTEM

The building owner must affix this notice in a conspicuous location near the access to the system.

This system must be used according to the state of the art and the instruction manual.

The storage location for the instruction manual, test logs, etc. is:

- Overview template showing the position of the anchorage device:

Draw in the areas where there is a break-through hazard (e.g. light domes and/or roof lights).

The maximum limit values of the anchorage devices are to be found in the respective instructions and on the rating plate of the fall protection system.

If there is strain caused by the fall, or if in doubt, the anchorage device must be taken out of service immediately and sent to the manufacturer, or to a specialist workshop for inspection and repair.
This applies if there is damage to the anchorage equipment.

TEST LOG NO. _____ (PART 1/2)

A I O - B K S

ORDER NUMBER: _____

PROJECT: _____

PRODUCT: Item _____ Year of construction/Serial number: _____
(Type of designation EAP/anchorage point)

ANNUAL SYSTEM INSPECTION EXECUTED ON: _____

LATEST DATE FOR NEXT ANNUAL SYSTEM INSPECTION: _____

CLIENT: _____ Specialist: _____ 
Company address: _____CLIENT: _____ Specialist: _____ 
Company address: _____

INSPECTION POINTS:	DEFECTS DEFECTED (Description of defects/measures)
<input checked="" type="checkbox"/> checked and in order!	
DOCUMENTATION:	
<input type="checkbox"/> Instruction manual	
<input type="checkbox"/> Acceptance logs/documentation of the anchorage/ photo documentation	
PPE (personal protective equipment against falls from a height): Inspection in accordance with the manufacturer's specifications	
<input type="checkbox"/> Expiration date	
<input type="checkbox"/> Annual inspection performed	
<input type="checkbox"/> Not checked (no authorisation)	
ROOF SEALIN:	
<input type="checkbox"/> no damage	
<input type="checkbox"/> no corrosion	
<input type="checkbox"/>	

TEST LOG NO. _____ (PART 2/2)

A I O - B K S

ORDER NUMBER: _____

PROJECT: _____

INSPECTION POINTS:	DEFECTS DETECTED:
<input checked="" type="checkbox"/> checked and in order!	(Description of defects/measures)
VISIBLE PARTS OF THE ANCHORAGE DEVICE:	
<input type="checkbox"/> no deformation	
<input type="checkbox"/> no corrosion	
<input type="checkbox"/> firmly seated	
<input type="checkbox"/> threaded joints secured	
<input type="checkbox"/> Tightening torque of the fastening bolts	
<input type="checkbox"/> Mobility of the attached parts (EAP, SZH, EDLE, etc.)	
HORIZONTAL LIFELINE SYSTEM:	
Attention: For horizontal lifeline systems the test log of the AllinOne TYPE instruction manual (see copy template in the instruction manual) must be filled out!	

The fall protection system corresponds to the specifications in the manufacturer's instruction manual and to the state of the art. Technical safety reliability is confirmed.
Anmerkungen: _____

Name: _____

Client

Inspection: Contractor (expert who is familiar with the fall protection system)

Date, company stamp, signature

Date, company stamp, signature

INNOTECH® Arbeitsschutz GmbH, Laizing 10, 4656 Kirchham/Österreich
www.innotech.at

