

Product number: IN-2168

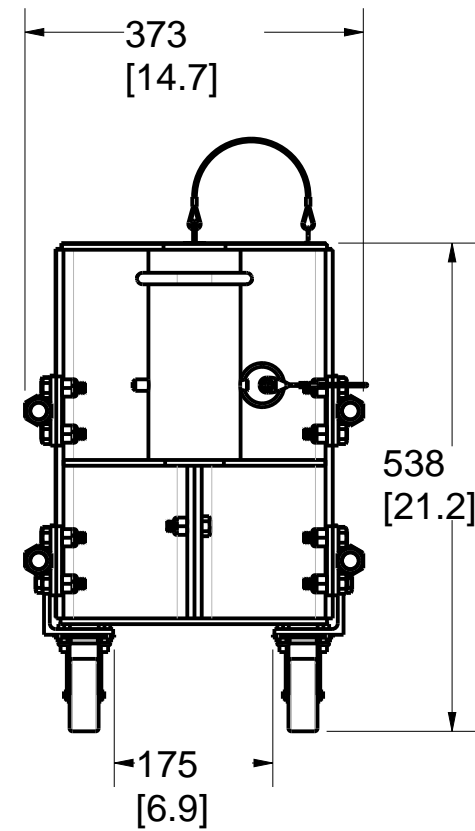
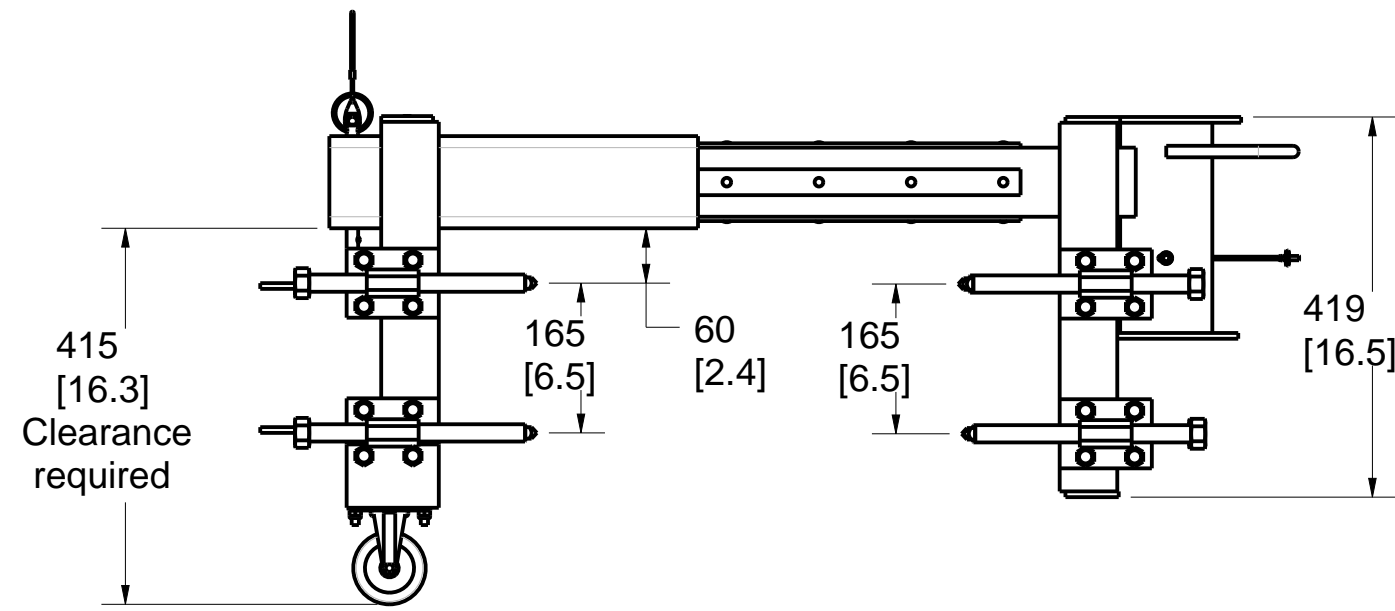
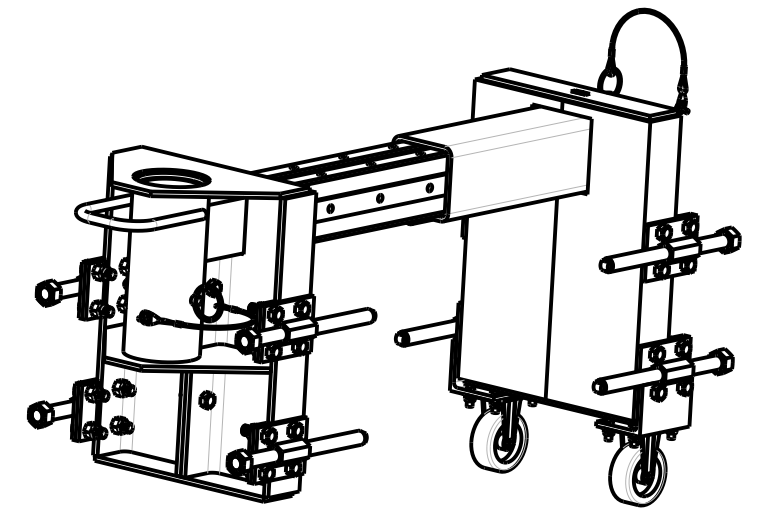
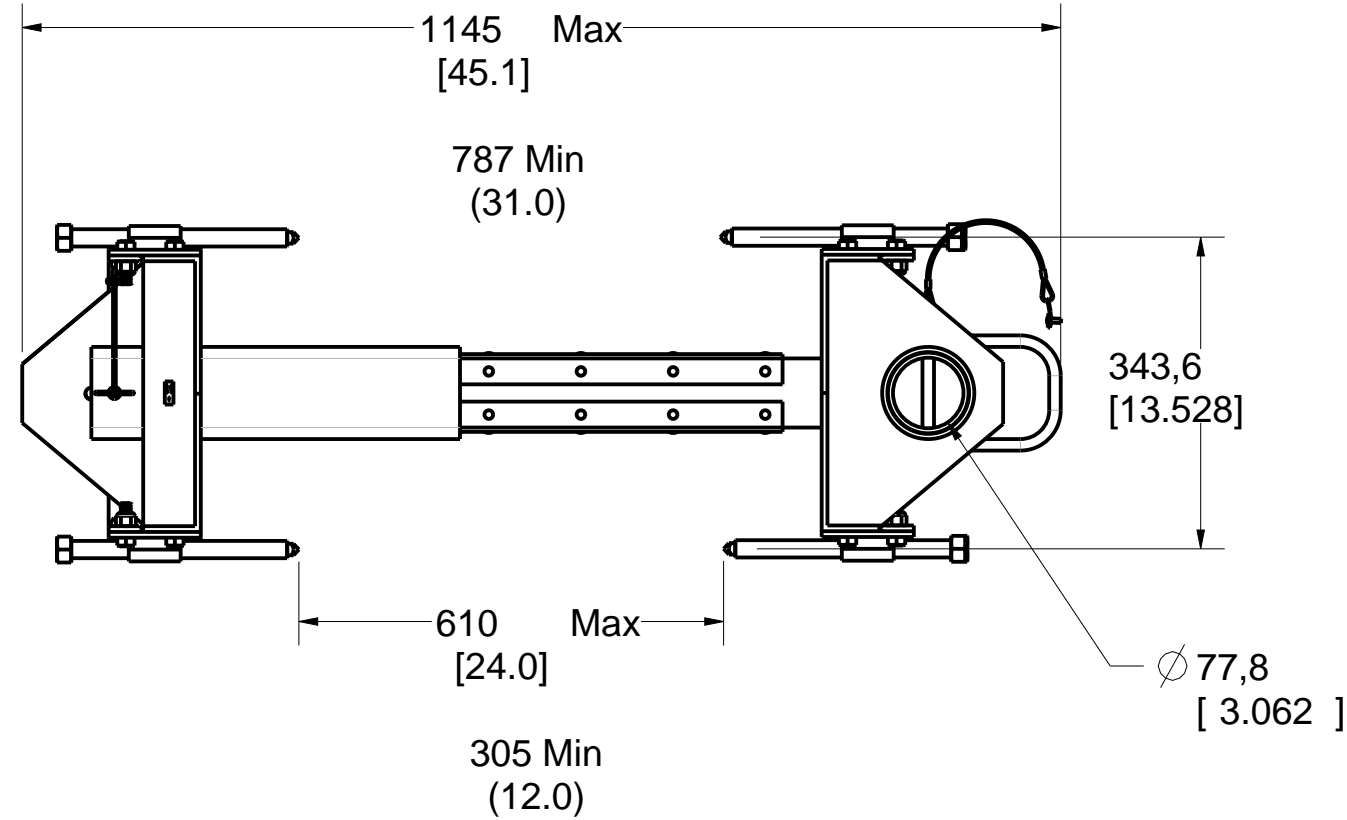

PAT. NO.:		©03/09/2008	©
PRODUITS DE SERVICE PUBLICS INNOVA INC. INNOVA PUBLIC UTILITY PRODUCTS INC.			
<small>© 9105-0732 QUEBEC INC. and under exclusive license to INNOVA PUBLIC UTILITY PRODUCTS INC., (hereafter « INNOVA »). All rights reserved. Protected under the Copyright Act of Canada and international treaties and agreements regarding copyrights. Violators are subject to prosecution and other legal recourses for infringement. Any reproduction, adaptation or other use or disclosure whatsoever, in totality or in part, and in any form or by any means whatsoever, strictly forbidden and requires the prior written approval of INNOVA. All data is the exclusive property of 9105-0732 QUEBEC INC. and under exclusive license to INNOVA and cannot be used nor disclosed in any way either without the prior written approval of INNOVA.</small>			
WEIGHT:	TITLE:		
68 Lb	76mm (3") Adjustable wall adapter		
31 Kg	305mm-610mm (12"-24")		
COLOR:	MATERIAL:	SHEET(S):	PROJECT:
Yellow security	Aluminum	1 / 5	IN-2168

Recommendations:

Concrete must be made of 0,2% gross area rebar reinforced
 13.8 MPa (2000psi) or better.
 Minimum thickness of 178mm (7")
 OR
 Non reinforced Concrete
 18.3MPa (2000psi) or better
 Minimum thickness of 286mm (11-1/4").

Moment capacity:
 13,558 N-m (120,000 lbf-in).
 Vertical load: 22,241 N (5,000 lbf).
 Note: It is the responsibility of the field engineer to assure installation compliance.

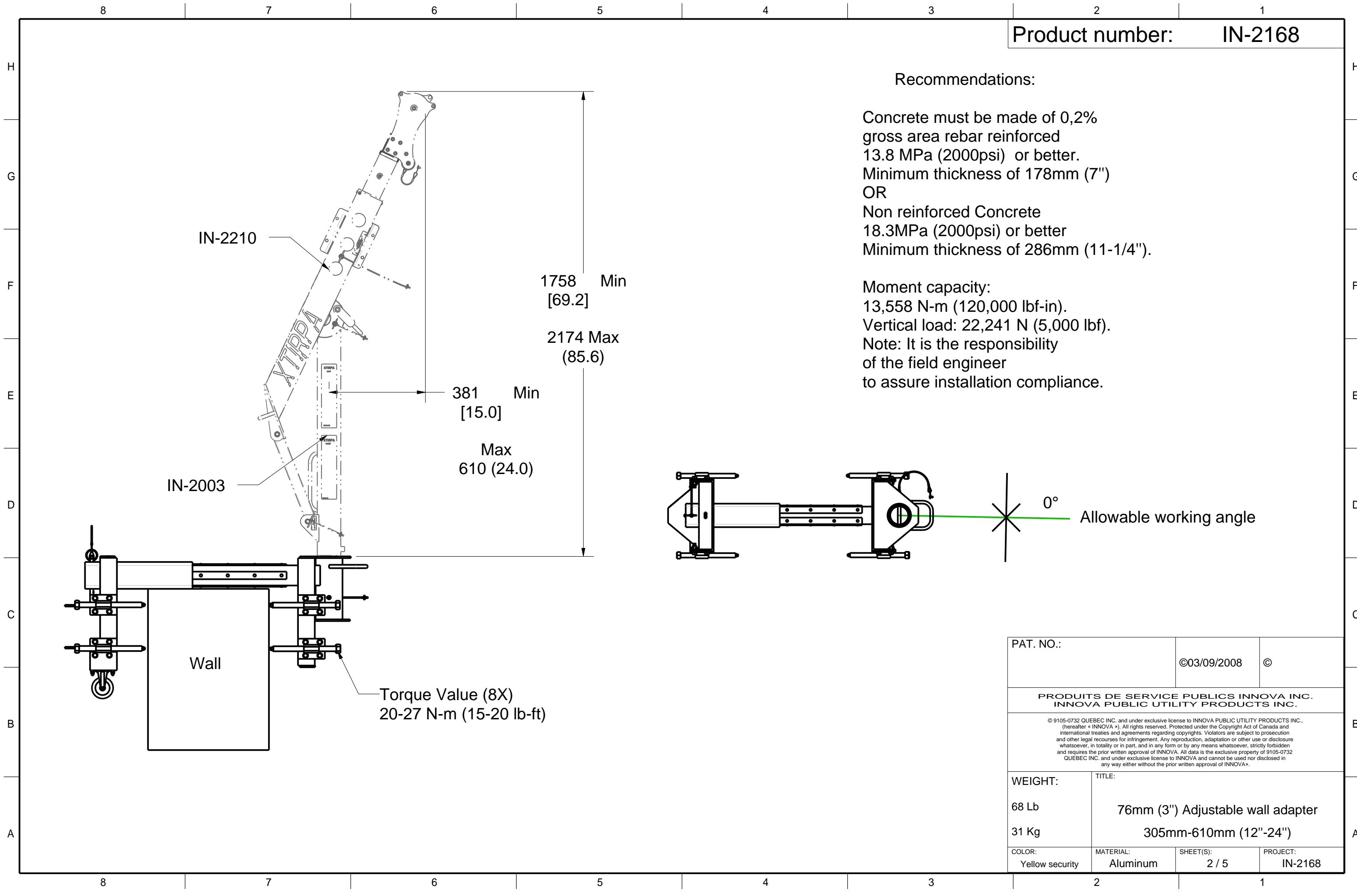

PAT. NO.:		©03/09/2008 ©	
PRODUITS DE SERVICE PUBLICS INNOVA INC. INNOVA PUBLIC UTILITY PRODUCTS INC.			
© 9105-0732 QUEBEC INC. and under exclusive license to INNOVA PUBLIC UTILITY PRODUCTS INC., (hereafter « INNOVA »). All rights reserved. Protected under the Copyright Act of Canada and international treaties and agreements regarding copyrights. Violators are subject to prosecution and other legal recourses for infringement. Any reproduction, adaptation or other use or disclosure whatsoever, in totality or in part, and in any form or by any means whatsoever, strictly forbidden and requires the prior written approval of INNOVA. All data is the exclusive property of 9105-0732 QUEBEC INC. and under exclusive license to INNOVA and cannot be used nor disclosed in any way either without the prior written approval of INNOVA.			
WEIGHT:	TITLE:		
68 Lb	76mm (3") Adjustable wall adapter 305mm-610mm (12"-24")		
31 Kg			
COLOR:	MATERIAL:	SHEET(S):	PROJECT:
Yellow security	Aluminum	2 / 5	IN-2168

Product number: IN-2168

SPECIFICATIONS

H This equipment is considered as part of a personal fall arrest system (PFAS) with a maximum working capacity of 164 Kg (360 lb).

It is only to be used in conjunction with a personal fall arrest system that limits the maximum arrest force (MAF).

G Maximum working moment : 976 N-m (8640 lbf-in)
Maximum moment : 9762 N-m (86400 lbf-in)

STANDARDS

Meets the following standards:

F OSHA Personal fall arrest system - 1910.66 App C
ANSI Safety requirements for personal fall arrest system, subsystems and components Z359.1 (R1999) / 2007
CAN/CSA Fall arresters, vertical lifelines, and rails Z259.2.1-98
CE EN 795: 2012 Type B.

MATERIAL AND CONSTRUCTION

E Principal body : Aluminum 6061-T6
Sleeve bearing : PVC pipe
Hardware : Zinc plated Steel
Screw plates : Zinc Plated Steel
Sliding strips : UHMW
Pin : Stainless Steel
D Lanyard : Nylon covered stainless steel cable
Welding certification : CSA W47,2M CSA W59 & 47.1, AWS D1.6

RESTRICTIONS

C This product is to be used only with products approved by Innova Public Utility Products inc.

IMPORTANT :

A minimum of 4 adjustment pins shall be used at all times on each side of the structure.

B Always use the product perpendicular to the wall. It is not considered as a permanent structure.

A **The positioning pins must always be in place when manoeuvring personnel. Otherwise, serious injuries may occur. Periodic inspections of hardware must be done. In the occurrence of a fall or the safety of the equipment is in doubt, equipment must be immediately removed from service and inspected by qualified personnel before reuse.

** This equipment must always be operated in a level position.

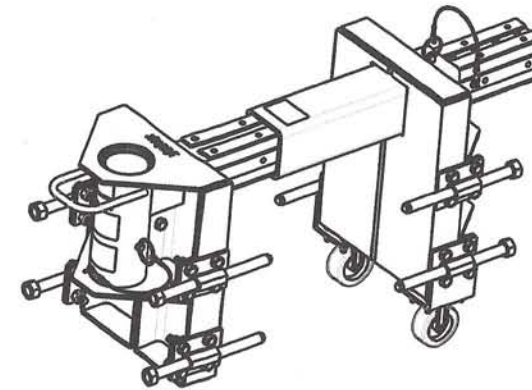

PAT. NO.:		©03/09/2008 ©	
PRODUITS DE SERVICE PUBLICS INNOVA INC. INNOVA PUBLIC UTILITY PRODUCTS INC.			
<small>© 9105-9732 QUÉBEC INC. and under exclusive license to INNOVA PUBLIC UTILITY PRODUCTS INC. Hereafter a "INNOVA". All rights reserved. Protected under the Copyright Act of Canada and international treaties and agreements regarding copyrights. Violators are subject to prosecution and other legal recourse for infringement. Any reproduction, adaptation or other use or disclosure whatsoever, in totality or in part, and in any form or by any means whatsoever, strictly forbidden and requires the prior written approval of INNOVA. All data is the exclusive property of 9105-9732 QUÉBEC INC. and under exclusive license to INNOVA and cannot be used nor disclosed in any way either without the prior written approval of INNOVA.</small>			
WEIGHT:	TITLE:		
68 Lb	76mm (3") Adjustable wall adapter		
31 Kg	305mm-610mm (12"-24")		
COLOR:	MATERIAL:	SHEET(S):	PROJECT:
Yellow security	Aluminum	3 / 5	IN-2168

8

7

6

5

4

3

2

1

Product number: IN-2168

IDX	QTE	COMPONENT	REV	DESCRIPTION
5	1	S2005-002	RevB	Label "WARNING" English
4	1	S2005-001	RevB	Label "ATTENTION" French
3	1	S2324-004	Rev.A	Security Label CE type B
2	1	S2001-003	04	XTIRPA Label
1	1	S2197-005		Label "Attention" French

H
G
F
E
D
C
B
A

H
G
F
E
D
C
B
A

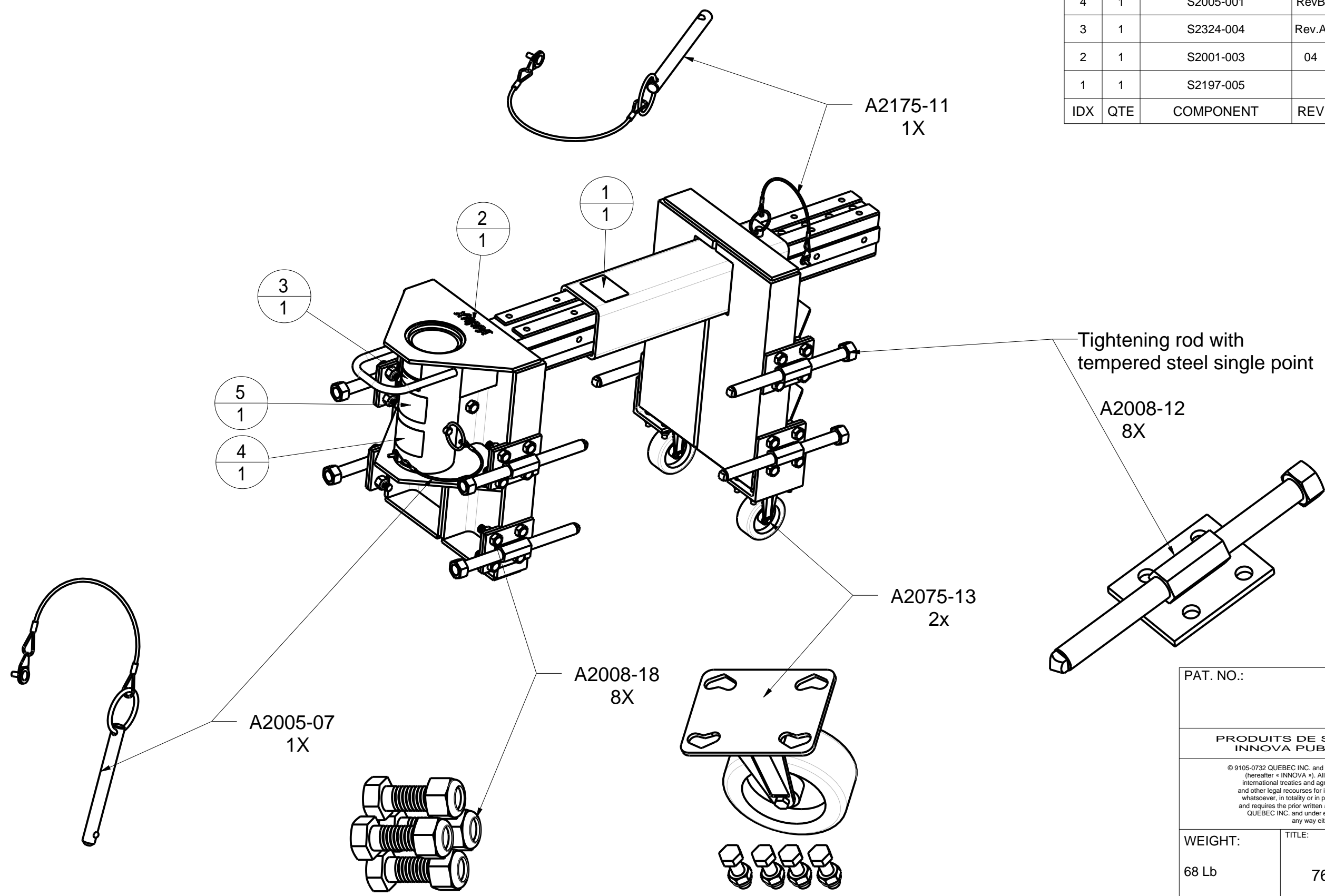

Tightening rod with tempered steel single point

A2008-12
8X

A2075-13
2X

A2008-18
8X

A2005-07
1X

A2175-11
1X

PAT. NO.:		©03/09/2008	©
PRODUITS DE SERVICE PUBLICS INNOVA INC. INNOVA PUBLIC UTILITY PRODUCTS INC.			
<small>© 9105-0732 QUEBEC INC. and under exclusive license to INNOVA PUBLIC UTILITY PRODUCTS INC., (hereafter « INNOVA »). All rights reserved. Protected under the Copyright Act of Canada and international treaties and agreements regarding copyrights. Violators are subject to prosecution and other legal recourses for infringement. Any reproduction, adaptation or other use or disclosure whatsoever, in totality or in part, and in any form or by any means whatsoever, strictly forbidden and requires the prior written approval of INNOVA. All data is the exclusive property of 9105-0732 QUEBEC INC. and under exclusive license to INNOVA and cannot be used nor disclosed in any way either without the prior written approval of INNOVA.</small>			
WEIGHT:	TITLE:		
68 Lb	76mm (3") Adjustable wall adapter		
31 Kg	305mm-610mm (12"-24")		
COLOR:	MATERIAL:	SHEET(S):	PROJECT:
Yellow security	Aluminum	4 / 5	IN-2168

8

7

6

5

4

3

2

1

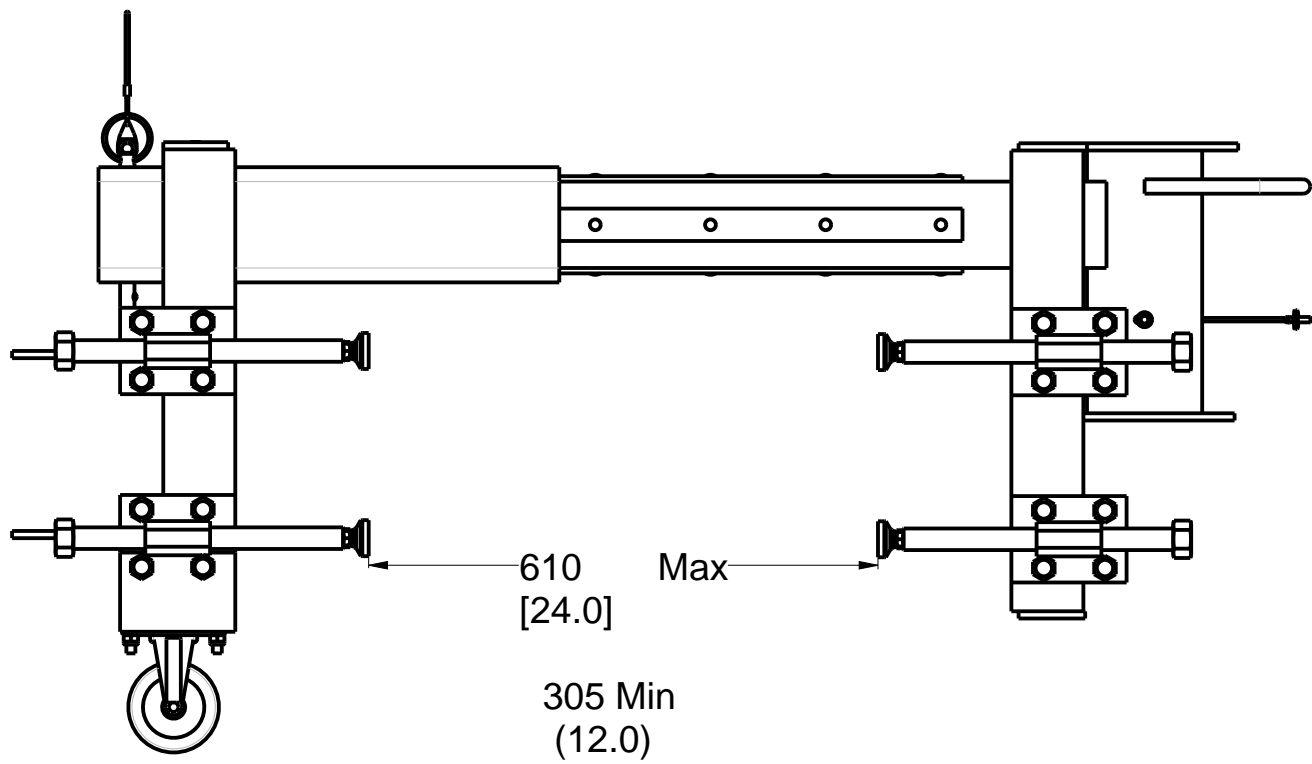
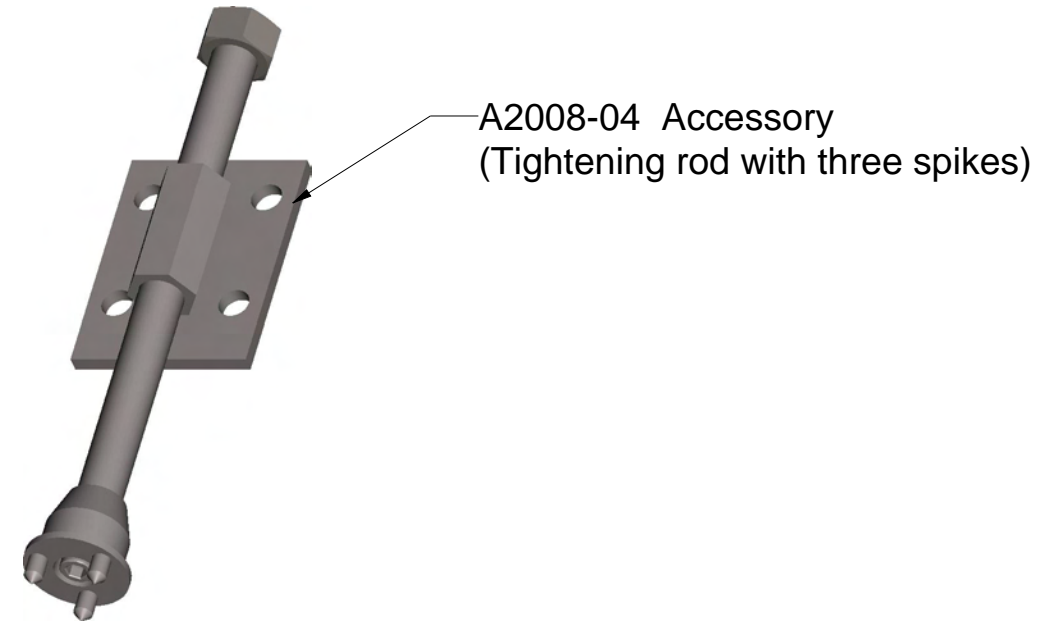
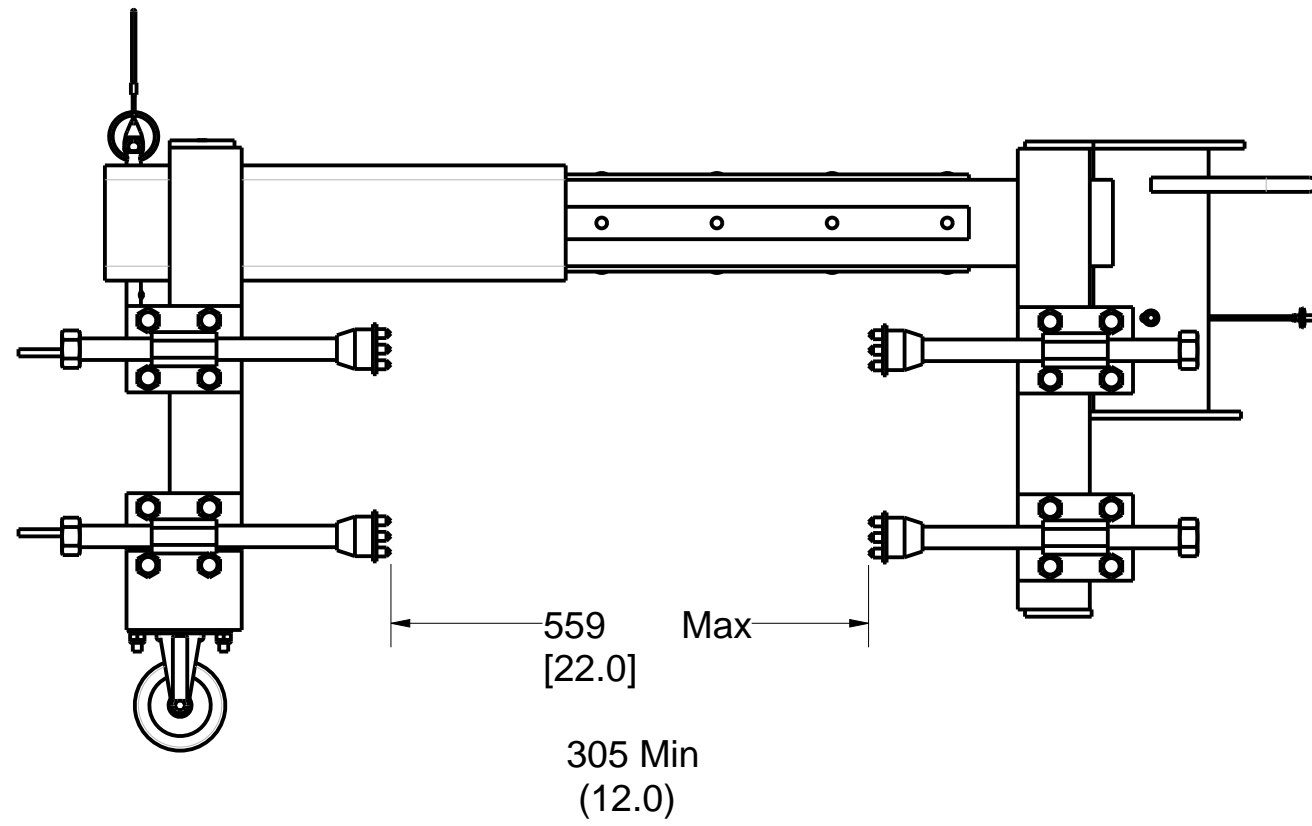

PAT. NO.:		©03/09/2008	©
PRODUITS DE SERVICE PUBLICS INNOVA INC. INNOVA PUBLIC UTILITY PRODUCTS INC.			
© 9105-0732 QUEBEC INC. and under exclusive license to INNOVA PUBLIC UTILITY PRODUCTS INC., (hereafter « INNOVA »). All rights reserved. Protected under the Copyright Act of Canada and international treaties and agreements regarding copyrights. Violators are subject to prosecution and other legal recourses for infringement. Any reproduction, adaptation or other use or disclosure whatsoever, in totality or in part, and in any form or by any means whatsoever, strictly forbidden and requires the prior written approval of INNOVA. All data is the exclusive property of 9105-0732 QUEBEC INC. and under exclusive license to INNOVA and cannot be used nor disclosed in any way either without the prior written approval of INNOVA.			
WEIGHT:	TITLE:		
68 Lb	76mm (3") Adjustable wall adapter		
31 Kg	305mm-610mm (12"-24")		
COLOR:	MATERIAL:	SHEET(S):	PROJECT:
Yellow security	Aluminum	5 / 5	IN-2168