

Product number: IN-2282

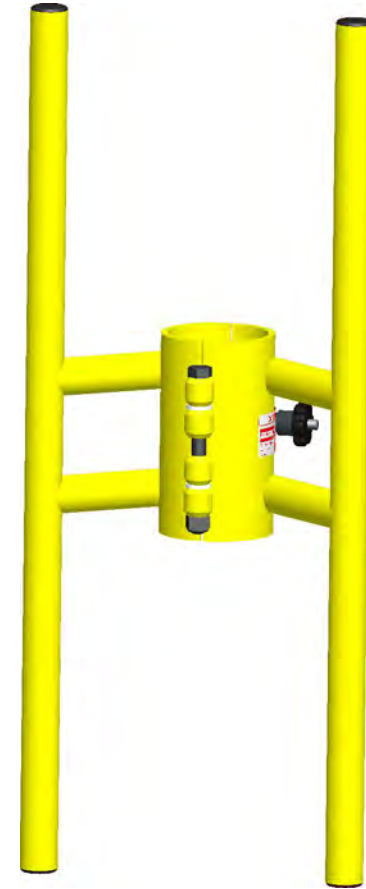

PAT. NO.:		©12/12/2011	©
PRODUITS DE SERVICE PUBLICS INNOVA INC. INNOVA PUBLIC UTILITY PRODUCTS INC.			
<small>© 9105-0732 QUEBEC INC. and under exclusive license to INNOVA PUBLIC UTILITY PRODUCTS INC., (hereafter « INNOVA »). All rights reserved. Protected under the Copyright Act of Canada and international treaties and agreements regarding copyrights. Violators are subject to prosecution and other legal recourses for infringement. Any reproduction, adaptation or other use or disclosure whatsoever, in totality or in part, and in any form or by any means whatsoever, strictly forbidden and requires the prior written approval of INNOVA. All data is the exclusive property of 9105-0732 QUEBEC INC. and under exclusive license to INNOVA and cannot be used nor disclosed in any way either without the prior written approval of INNOVA.</small>			
WEIGHT:	TITLE:		
5.5 Lbs	Adaptable Handrail for IN-2003 Mast		
2.495 Kg			
COLOR:	MATERIAL:	SHEET(S):	PROJECT:
Yellow security	Aluminum	1 / 3	IN-2282

Product number: IN-2282

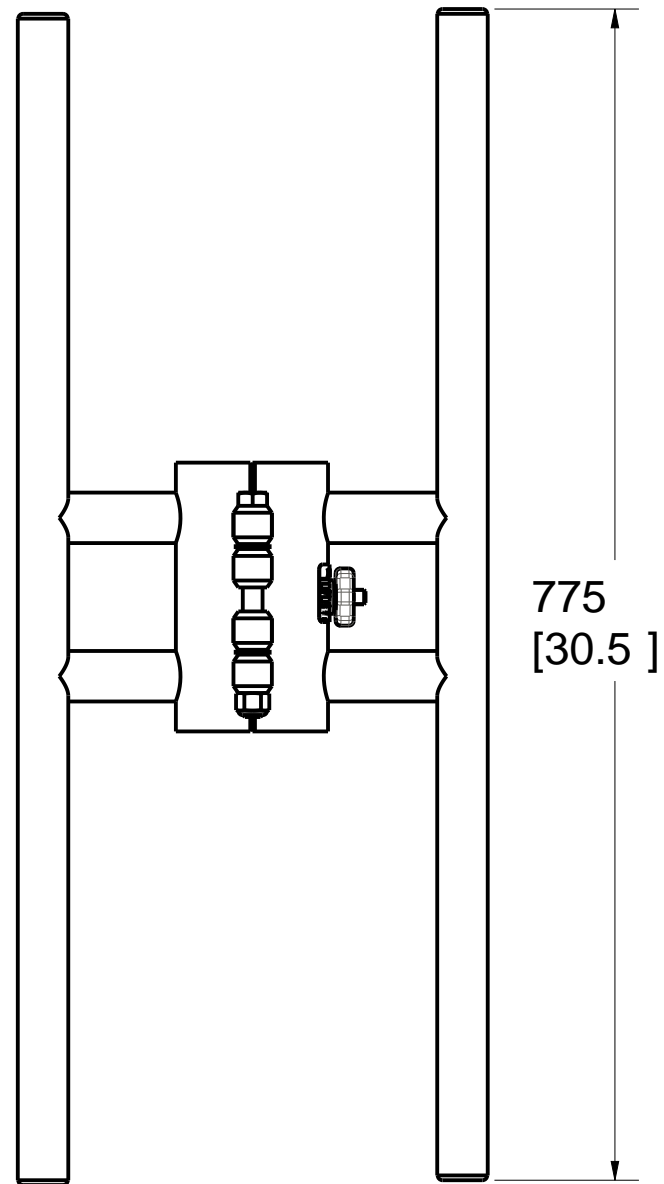
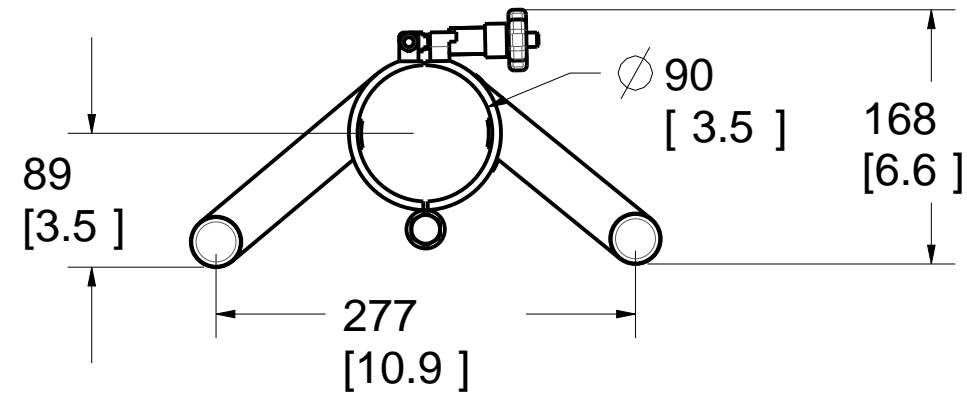
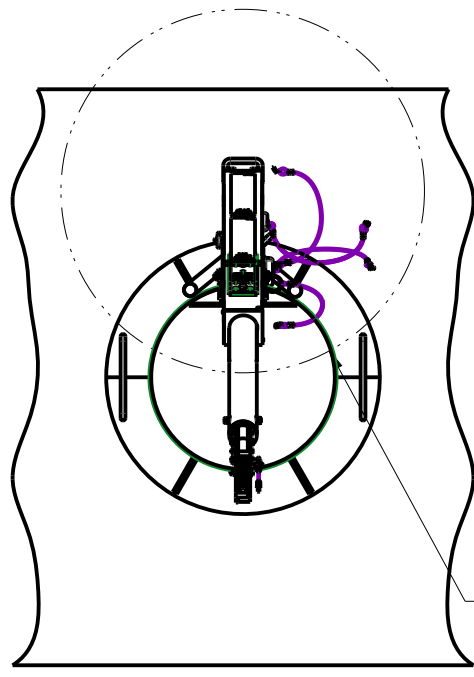

SEE DETAIL A

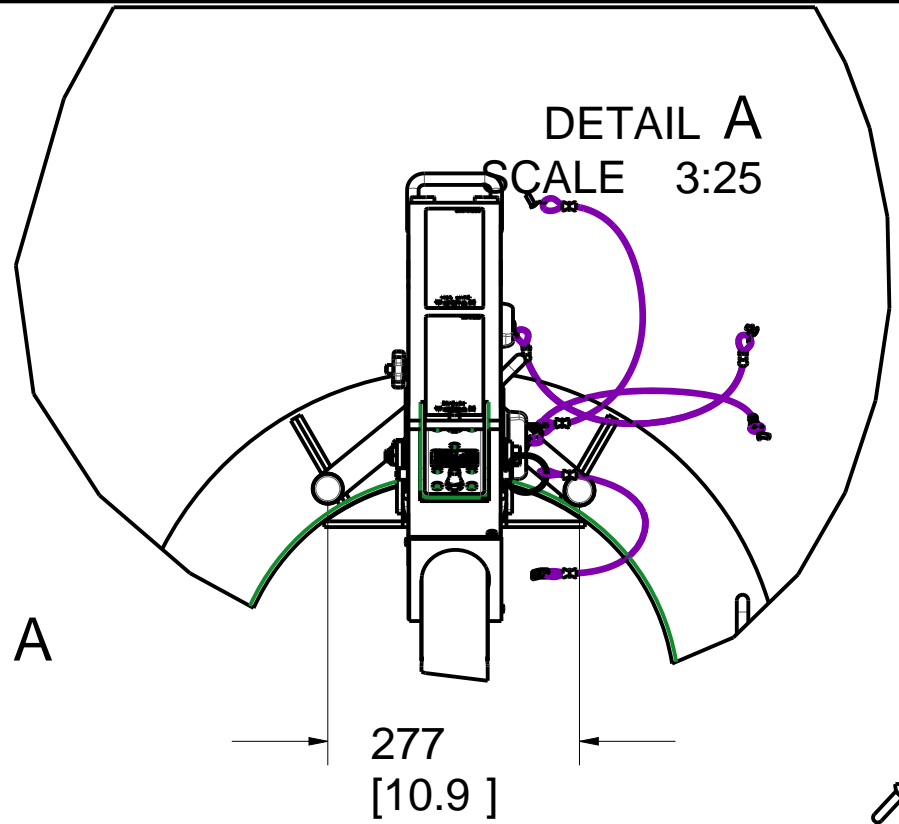

277
[10.9]

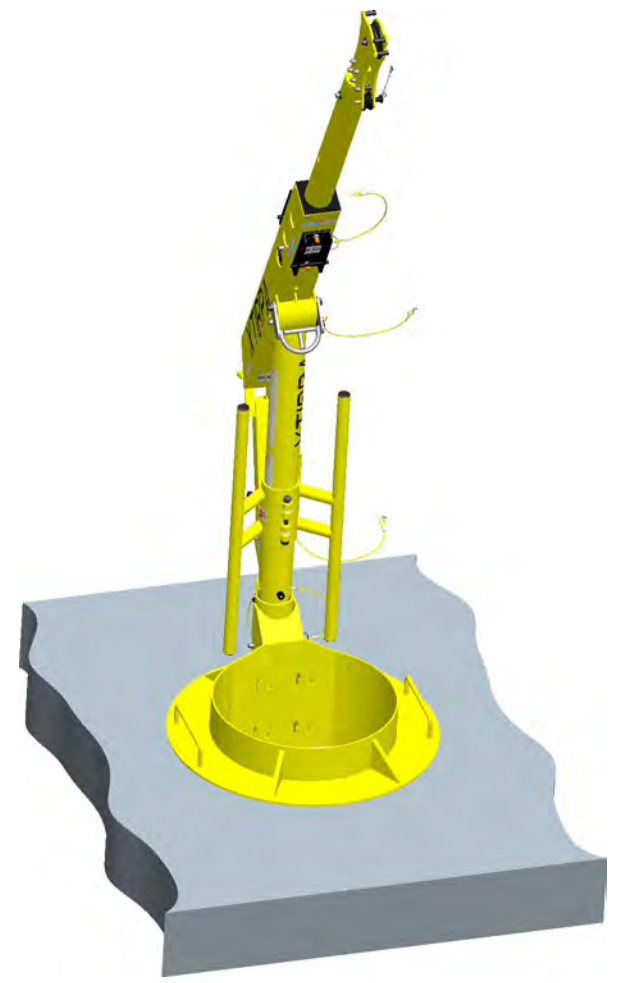

DETAIL B
SCALE 1:10

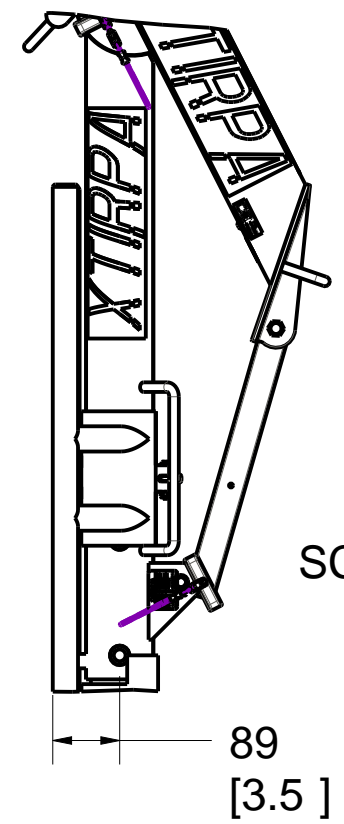

89
[3.5]

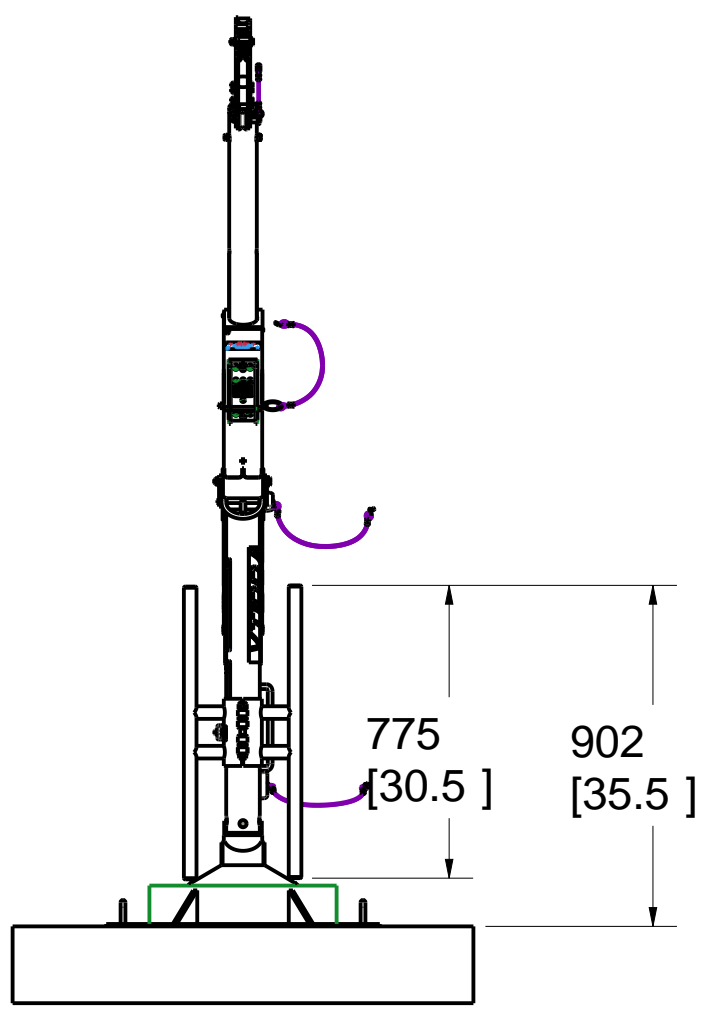

775
[30.5] 902
[35.5]

Davit-Arm
IN-2210

Mast
IN-2003

Manhole collar

SEE DETAIL B

PAT. NO.:		©12/12/2011	©
PRODUITS DE SERVICE PUBLICS INNOVA INC. INNOVA PUBLIC UTILITY PRODUCTS INC.			
<small>© 9105-0732 QUEBEC INC. and under exclusive license to INNOVA PUBLIC UTILITY PRODUCTS INC., (hereafter « INNOVA »). All rights reserved. Protected under the Copyright Act of Canada and international treaties and agreements regarding copyrights. Violators are subject to prosecution and other legal recourses for infringement. Any reproduction, adaptation or other use or disclosure whatsoever, in totality or in part, and in any form or by any means whatsoever, strictly forbidden and requires the prior written approval of INNOVA. All data is the exclusive property of 9105-0732 QUEBEC INC. and under exclusive license to INNOVA and cannot be used nor disclosed in any way either without the prior written approval of INNOVA.</small>			
WEIGHT:	TITLE:		
5.5 Lbs	Adaptable Handrail for IN-2003 Mast		
2.495 Kg			
COLOR:	MATERIAL:	SHEET(S):	PROJECT:
Yellow security	Aluminum	2 / 3	IN-2282

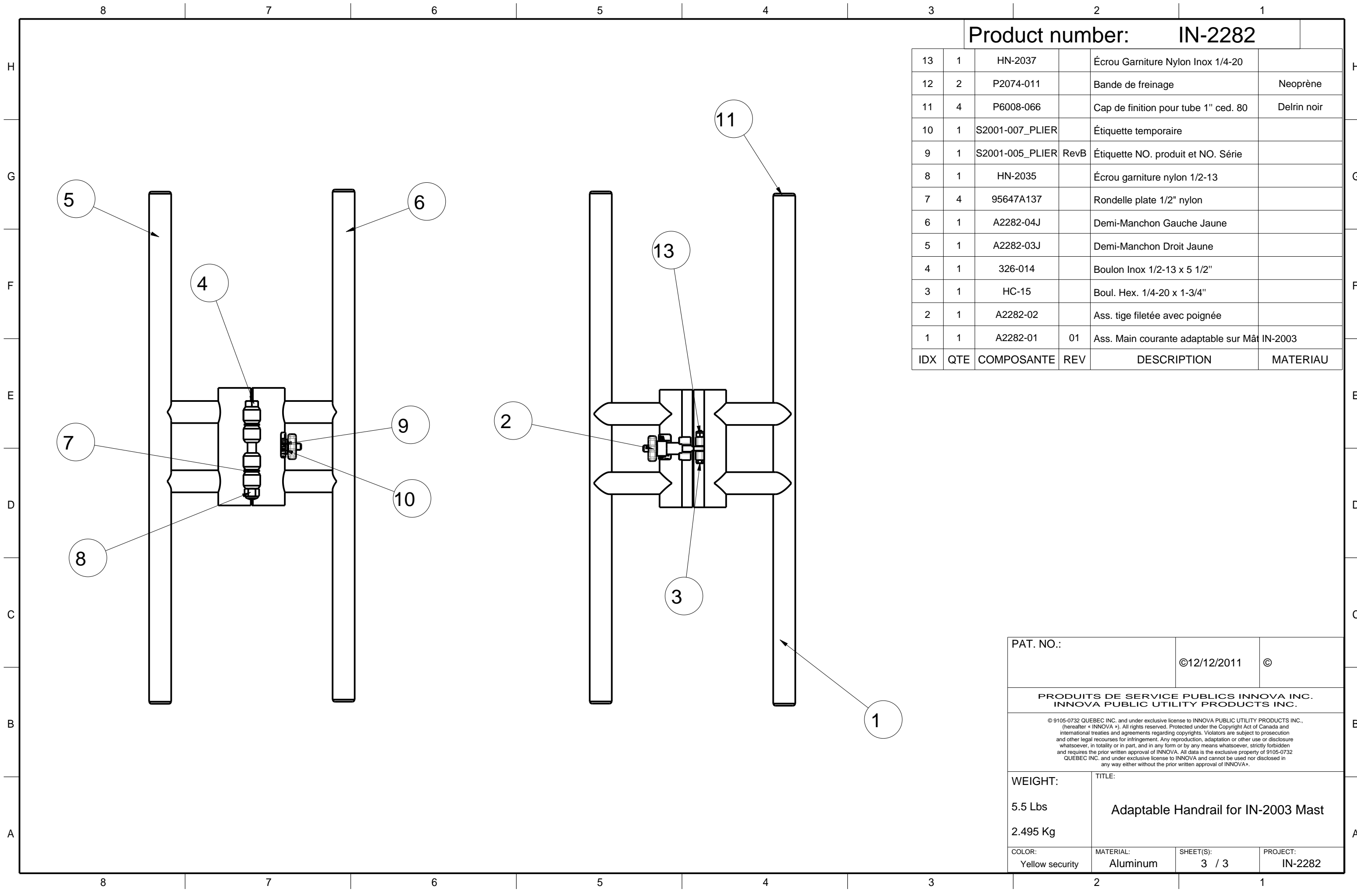

Product number: **IN-2282**

IDX	QTE	COMPOSANTE	REV	DESCRIPTION	MATERIAU
13	1	HN-2037		Écrou Garniture Nylon Inox 1/4-20	
12	2	P2074-011		Bande de freinage	Neoprène
11	4	P6008-066		Cap de finition pour tube 1" ced. 80	Delrin noir
10	1	S2001-007_PLIER		Étiquette temporaire	
9	1	S2001-005_PLIER	RevB	Étiquette NO. produit et NO. Série	
8	1	HN-2035		Écrou garniture nylon 1/2-13	
7	4	95647A137		Rondelle plate 1/2" nylon	
6	1	A2282-04J		Demi-Manchon Gauche Jaune	
5	1	A2282-03J		Demi-Manchon Droit Jaune	
4	1	326-014		Boulon Inox 1/2-13 x 5 1/2"	
3	1	HC-15		Boul. Hex. 1/4-20 x 1-3/4"	
2	1	A2282-02		Ass. tige filetée avec poignée	
1	1	A2282-01	01	Ass. Main courante adaptable sur Mât IN-2003	

PAT. NO.:		©12/12/2011	©
PRODUITS DE SERVICE PUBLICS INNOVA INC. INNOVA PUBLIC UTILITY PRODUCTS INC.			
<small>© 9105-0732 QUEBEC INC. and under exclusive license to INNOVA PUBLIC UTILITY PRODUCTS INC., (hereafter « INNOVA »). All rights reserved. Protected under the Copyright Act of Canada and international treaties and agreements regarding copyrights. Violators are subject to prosecution and other legal recourses for infringement. Any reproduction, adaptation or other use or disclosure whatsoever, in totality or in part, and in any form or by any means whatsoever, strictly forbidden and requires the prior written approval of INNOVA. All data is the exclusive property of 9105-0732 QUEBEC INC. and under exclusive license to INNOVA and cannot be used nor disclosed in any way either without the prior written approval of INNOVA.</small>			
WEIGHT:	TITLE:		
5.5 Lbs	Adaptable Handrail for IN-2003 Mast		
2.495 Kg			
COLOR:	MATERIAL:	SHEET(S):	PROJECT:
Yellow security	Aluminum	3 / 3	IN-2282