

Product number: IN-2315

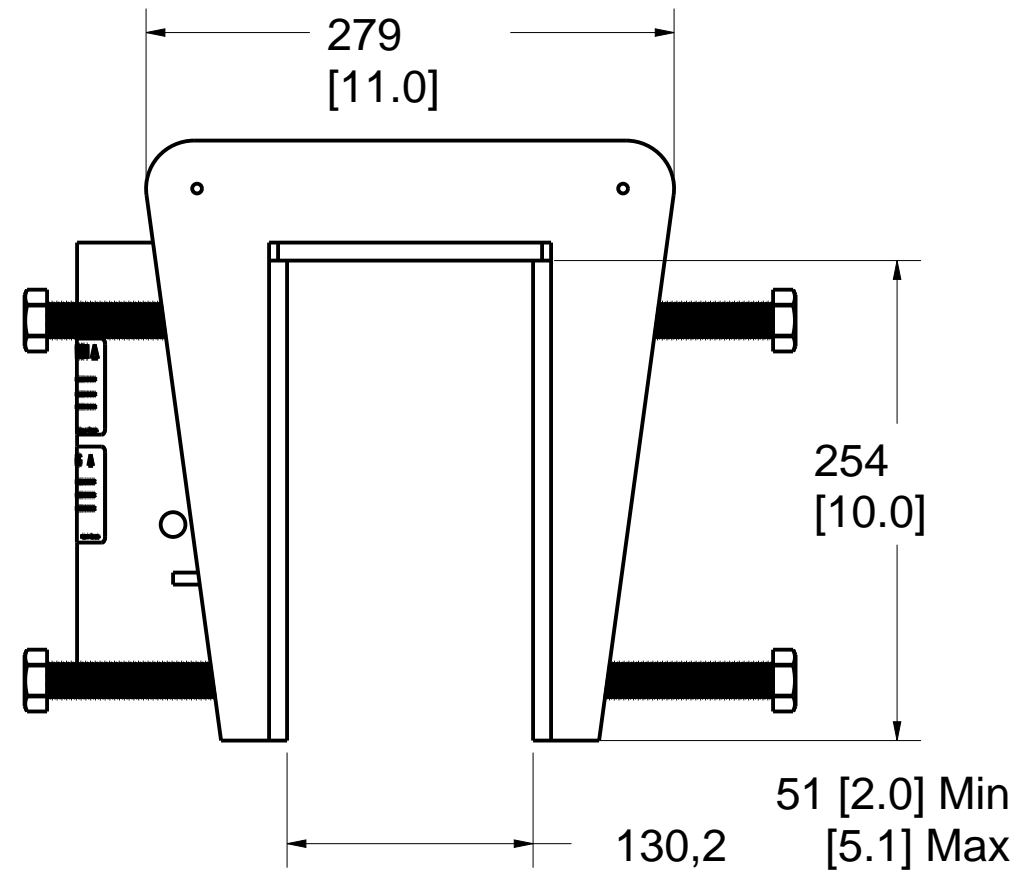
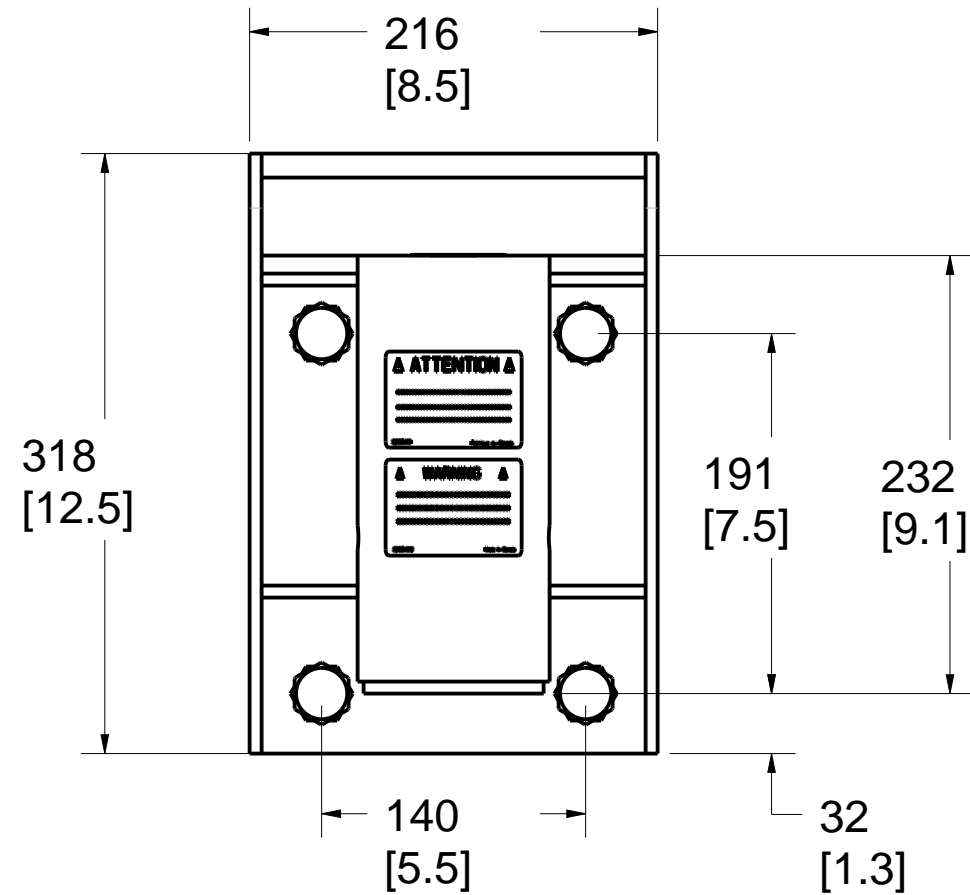
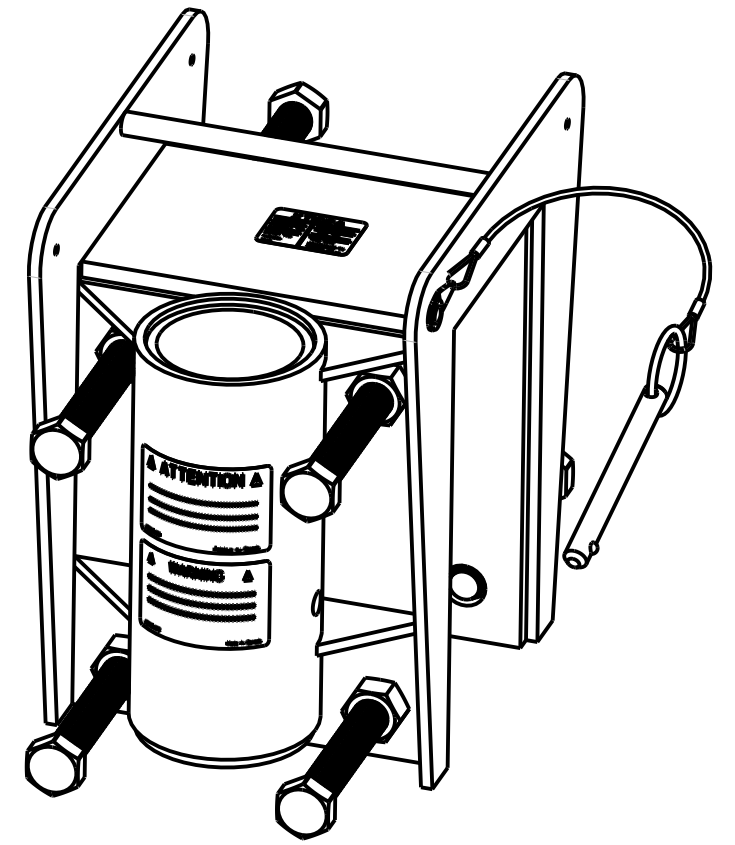
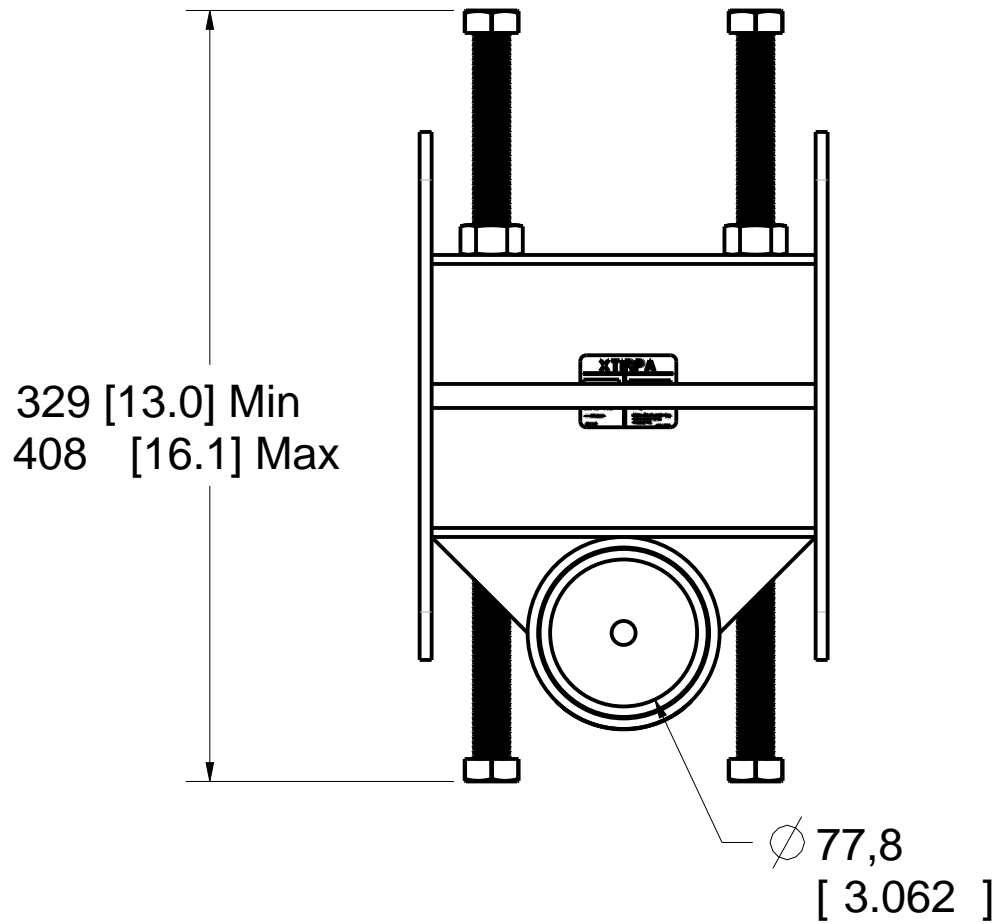

PAT. NO.:		©16/05/2012	©
PRODUITS DE SERVICE PUBLICS INNOVA INC. INNOVA PUBLIC UTILITY PRODUCTS INC.			
<small>© 9105-0732 QUEBEC INC. and under exclusive license to INNOVA PUBLIC UTILITY PRODUCTS INC., (hereafter « INNOVA »). All rights reserved. Protected under the Copyright Act of Canada and international treaties and agreements regarding copyrights. Violators are subject to prosecution and other legal recourses for infringement. Any reproduction, adaptation or other use or disclosure whatsoever, in totality or in part, and in any form or by any means whatsoever, strictly forbidden and requires the prior written approval of INNOVA. All data is the exclusive property of 9105-0732 QUEBEC INC. and under exclusive license to INNOVA and cannot be used nor disclosed in any way either without the prior written approval of INNOVA.</small>			
WEIGHT:	TITLE:		
47 Lb	76mm (3") Barrel adapter		
21 Kg	51mm-127mm (2"-5") (zinc plated)		
COLOR:	MATERIAL:	SHEET(S):	PROJECT:
Zinc plated	Steel 44W	1 / 4	IN-2315

**IMPORTANT:**

Product shall only be used perpendicular to wall.

Wall recommendations:  
Moment capacity: 120,000 lb-po (13,558 N-m)

Vertical load: 5,000 lbf (22,241 N).

N.B. It is the responsibility of the field engineer to assure installation and use compliance.

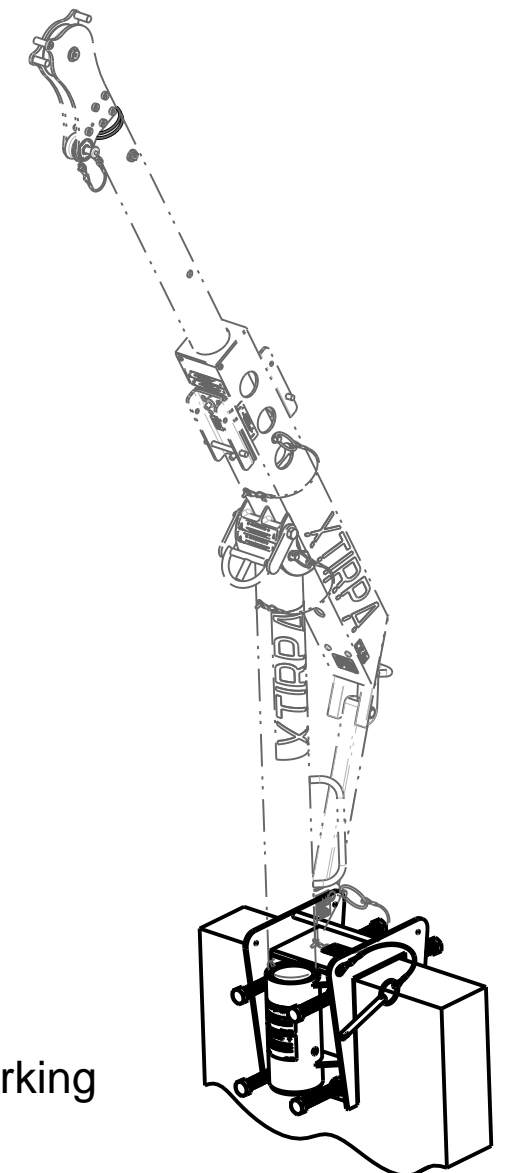
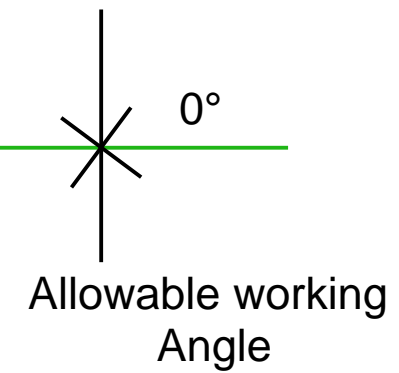
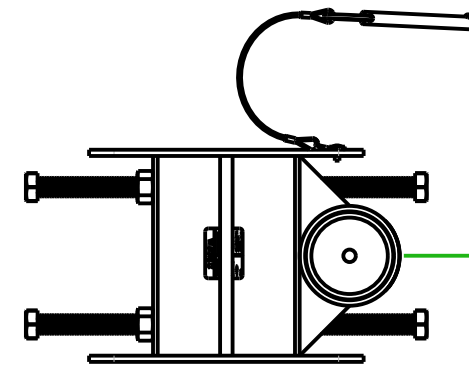

Min  
1727 [68.0]  
Max  
2159 [85.0]

Min  
381 [15.0]  
Max  
610 [24.0]

89  
[3.5]

216  
[8.5]

PAT. NO.:		©16/05/2012	©
<b>PRODUITS DE SERVICE PUBLICS INNOVA INC.</b> <b>INNOVA PUBLIC UTILITY PRODUCTS INC.</b>			
© 9105-0732 QUEBEC INC. and under exclusive license to INNOVA PUBLIC UTILITY PRODUCTS INC., (hereafter « INNOVA »). All rights reserved. Protected under the Copyright Act of Canada and international treaties and agreements regarding copyrights. Violators are subject to prosecution and other legal recourses for infringement. Any reproduction, adaptation or other use or disclosure whatsoever, in totality or in part, and in any form or by any means whatsoever, strictly forbidden and requires the prior written approval of INNOVA. All data is the exclusive property of 9105-0732 QUEBEC INC. and under exclusive license to INNOVA and cannot be used nor disclosed in any way either without the prior written approval of INNOVA.			
WEIGHT:	TITLE:		
47 Lb	76mm (3") Barrel adapter		
21 Kg	51mm-127mm (2"-5") (zinc plated)		
COLOR:	MATERIAL:	SHEET(S):	PROJECT:
Zinc plated	Steel 44W	2 / 4	IN-2315

Product number: IN-2315

SPECIFICATIONS

H This equipment is considered as part of a personal fall arrest system (PFAS) with a maximum working capacity of 164 Kg (360 lb).

It is only to be used in conjunction with a personal fall arrest system that limits the maximum arrest force (MAF).

G Maximum working moment : 976 N-m (8,640 lbf-in)  
Maximum moment : 9,762 N-m (86,400 lbf-in)

The wall shall be able to support a vertical load of 22,241 N (5,000 lbf) and a moment of 13,558 N-m (120,000 lbf-in).

STANDARDS

F Meets the following standards:  
OSHA Personal fall arrest system - 1910.66 App C  
ANSI Safety requirements for personal fall arrest system, subsystems and components Z359.1 / 2007  
CAN/CSA Fall arresters, vertical lifelines, and rails Z259.2.1-98 (R2011)  
CE EN 795: 2012 Type B

MATERIAL AND CONSTRUCTION

E Plate and gussets : Steel 44W (300W) CSA G40.21  
Sleeve : Steel 1026 DOM  
Finish : Clear Zinc plated, ASTM B-633-11, Type V, SC3.  
Sleeve bearing : PVC.  
D Pin : Stainless steel  
Lanyard : Nylon covered stainless steel cable  
Hardware : Gr. 5 Zinc plated steel  
Welding Certification : As per CSA 47,1

RESTRICTIONS

C This product is to be used only with products approved by Innova Public Utility Products inc.

IMPORTANT :

B \*\*The positioning pins must always be in place when manoeuvring personnel. Otherwise, serious injuries may occur.  
Periodic inspections of hardware must be done.  
Always use the product perpendicular to the wall. It is not considered as a permanent structure.  
In the occurrence of a fall or the safety of the equipment is in doubt, equipment must be immediately removed from service and inspected by qualified personnel before reuse.

A \*\* This equipment must always be operated in a level position.

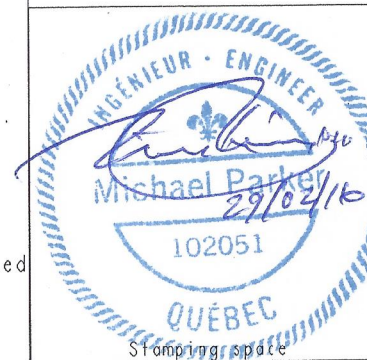
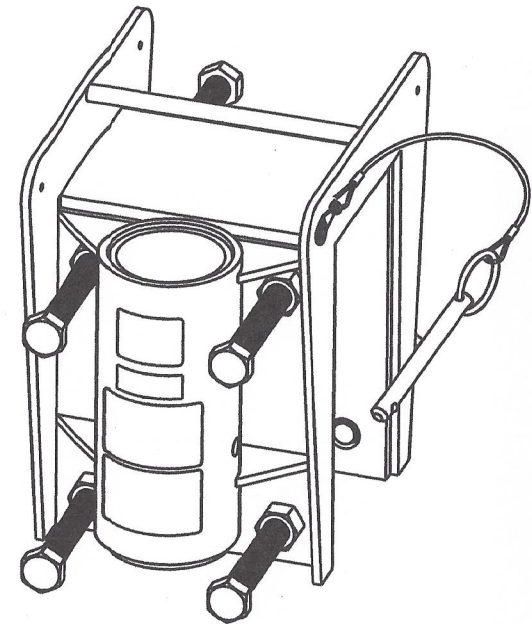

PAT. NO. :		©16/05/2012 ©	
PRODUITS DE SERVICE PUBLICS INNOVA INC. INNOVA PUBLIC UTILITY PRODUCTS INC.			
<small>© 9105-8732 QUEBEC INC. and under exclusive license to INNOVA PUBLIC UTILITY PRODUCTS INC. (hereafter « INNOVA »). All rights reserved. Protected under the Copyright Act of Canada and International treaties and agreements regarding copyrights. Violators are subject to prosecution and other legal recourse for infringement. Any reproduction, adaptation or other use or disclosure whatsoever, in totality or in part, and in any form or by any means whatsoever, strictly forbidden and requires the prior written approval of INNOVA. All data is the exclusive property of 9105-8732 QUEBEC INC. and under exclusive license to INNOVA and cannot be used nor disclosed in any way either without the prior written approval of INNOVA.</small>			
WEIGHT :	TITLE :		
47 Lb	76mm (3") Barrel adapter		
21 Kg	51mm-127mm (2"-5") (zinc plated)		
COLOR :	MATERIAL :	SHEETS(S) :	PROJECT :
Zinc plated	Steel 44W	3 / 4	IN-2315

Stamping space

8

7

6

5

4

3

2

1

H  
G  
F  
E  
D  
C  
B  
A

Product number: **IN-2315**

2	1	S2005-002	RevB	Label "WARNING" English
1	1	S2005-001	RevB	Label "ATTENTION" French
IDX	QTE	COMPONENT	REV	DESCRIPTION

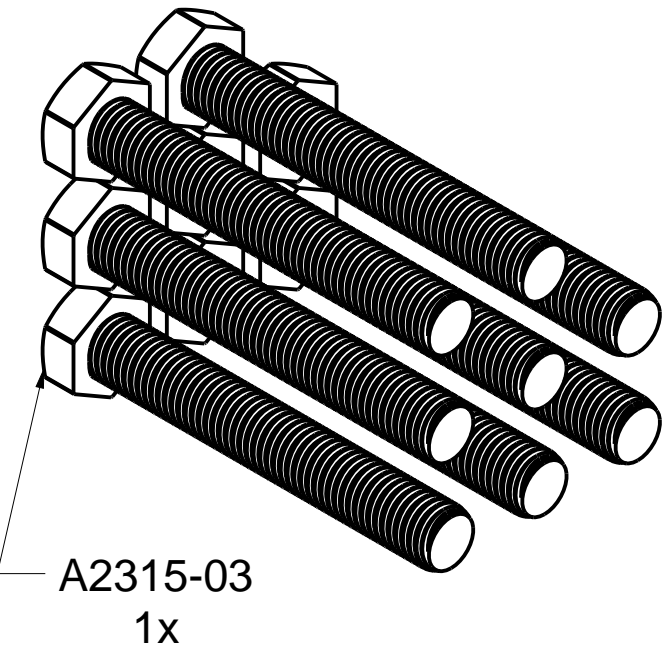
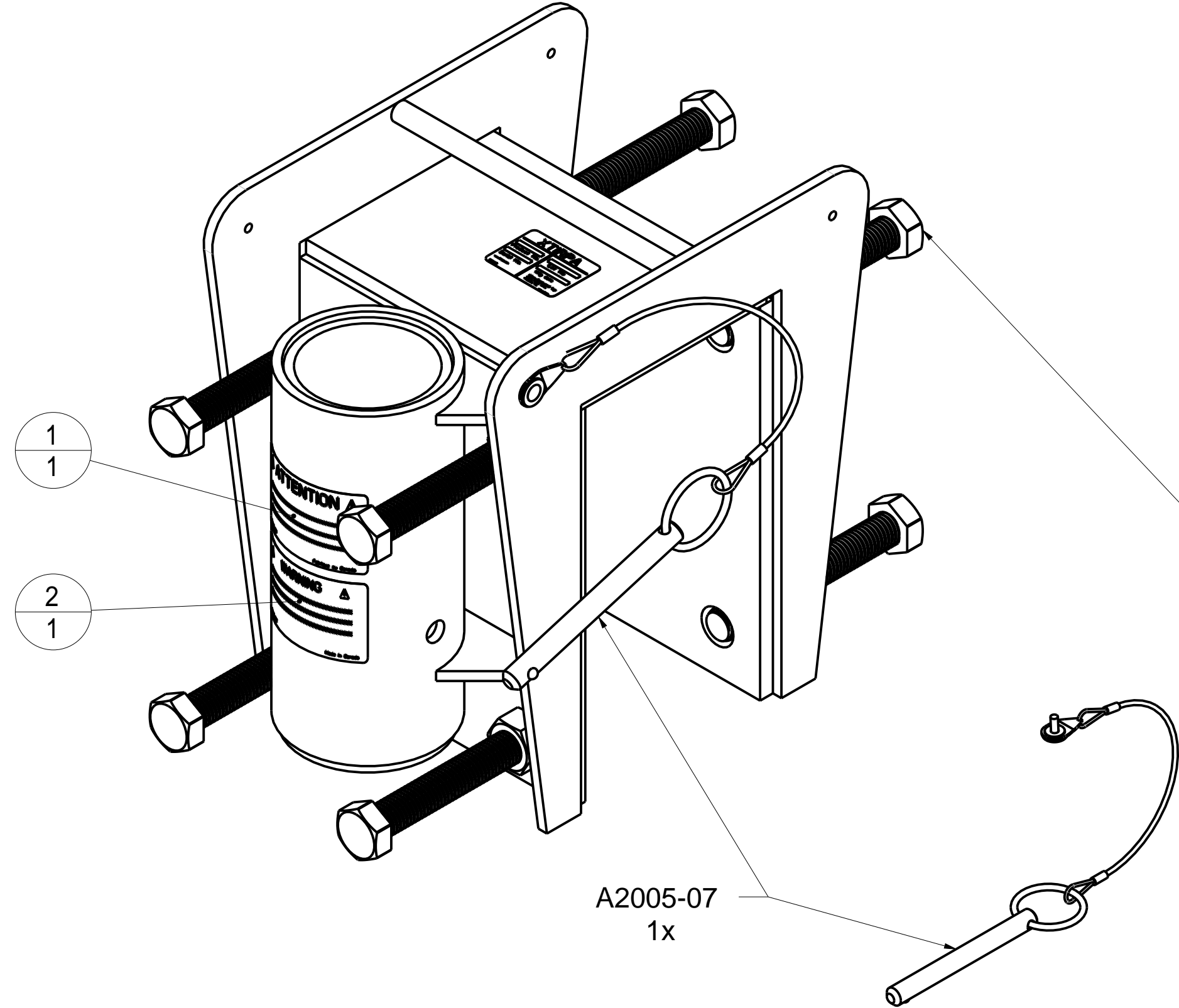

A2005-07  
1x

A2315-03  
1x

PAT. NO.:		©16/05/2012	©
<b>PRODUITS DE SERVICE PUBLICS INNOVA INC.</b> <b>INNOVA PUBLIC UTILITY PRODUCTS INC.</b>			
<small>© 9105-0732 QUEBEC INC. and under exclusive license to INNOVA PUBLIC UTILITY PRODUCTS INC., (hereafter « INNOVA »). All rights reserved. Protected under the Copyright Act of Canada and international treaties and agreements regarding copyrights. Violators are subject to prosecution and other legal recourses for infringement. Any reproduction, adaptation or other use or disclosure whatsoever, in totality or in part, and in any form or by any means whatsoever, strictly forbidden and requires the prior written approval of INNOVA. All data is the exclusive property of 9105-0732 QUEBEC INC. and under exclusive license to INNOVA and cannot be used nor disclosed in any way either without the prior written approval of INNOVA.</small>			
WEIGHT:	TITLE:		
47 Lb	76mm (3") Barrel adapter		
21 Kg	51mm-127mm (2"-5") (zinc plated)		
COLOR:	MATERIAL:	SHEET(S):	PROJECT:
Zinc plated	Steel 44W	4 / 4	IN-2315

8

7

6

5

4

3

2

1