

18

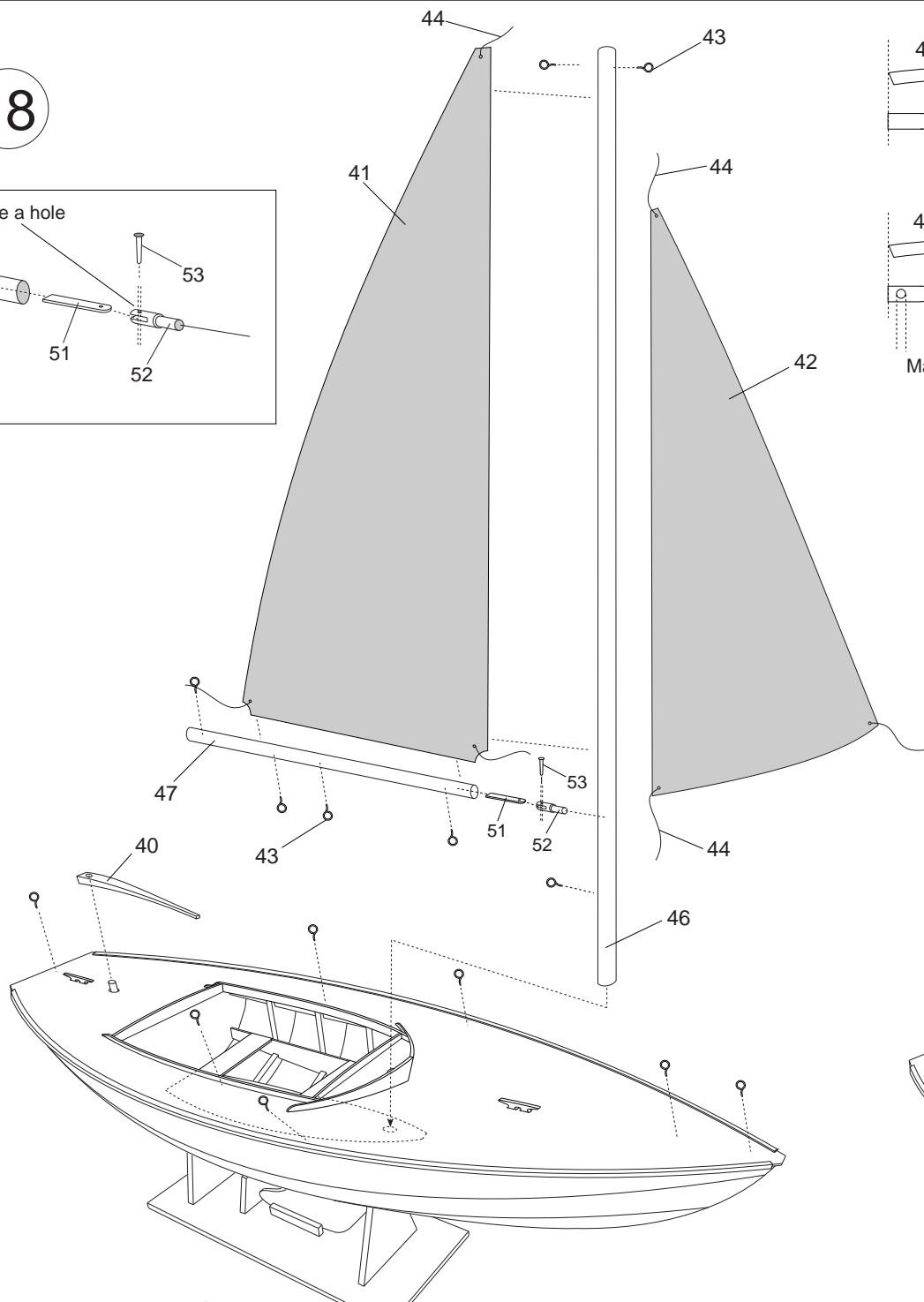

19

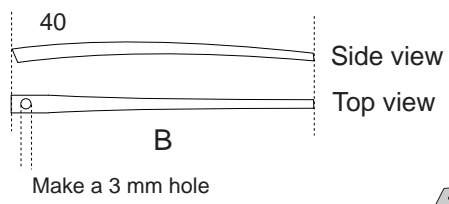
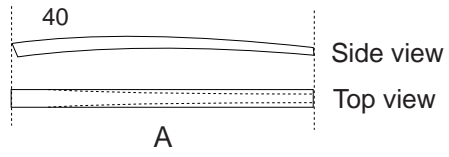
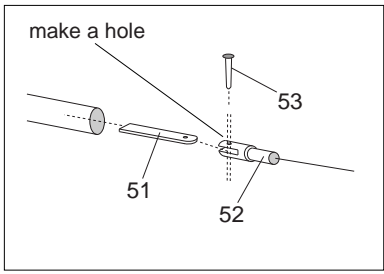
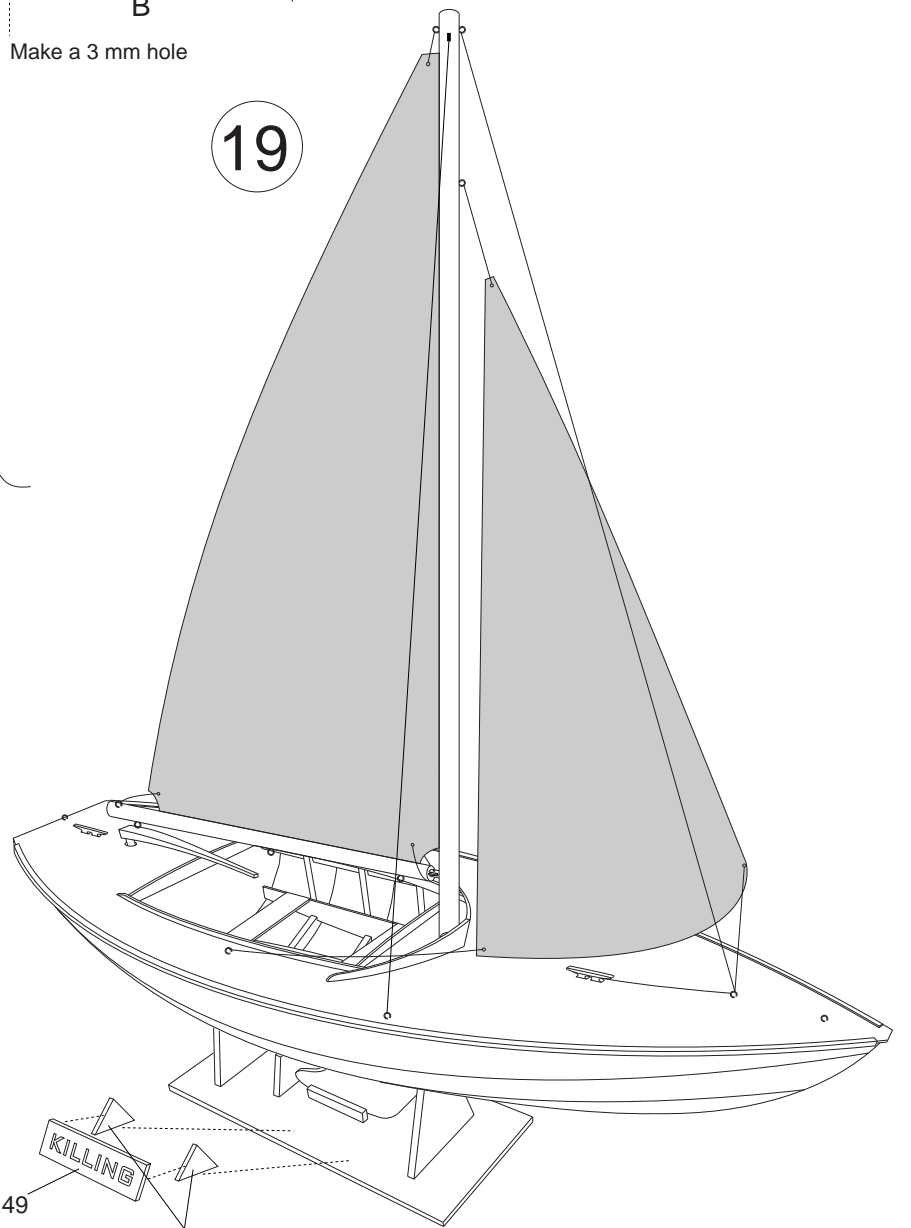

20

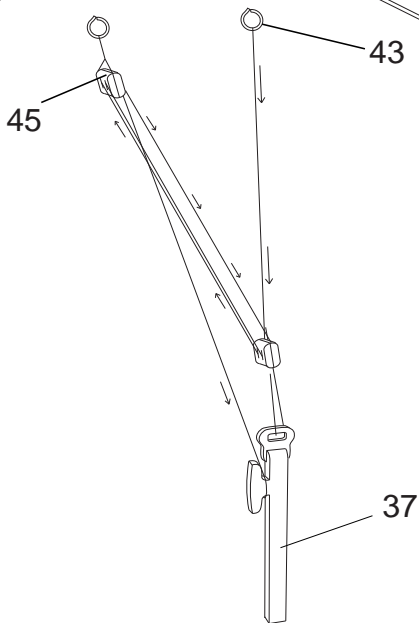

21

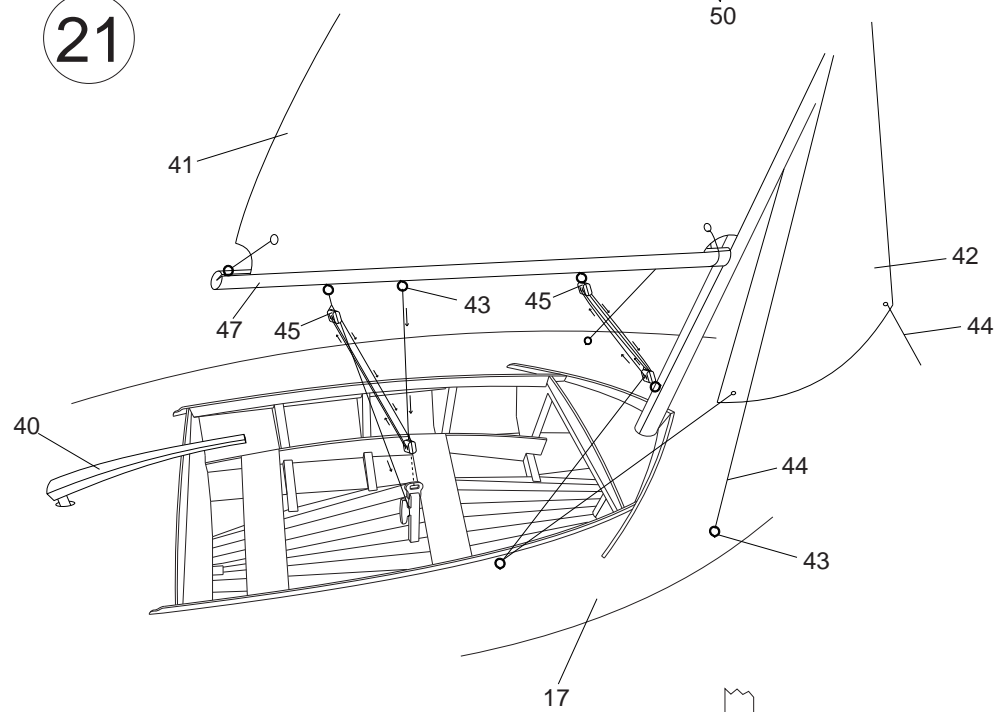

22

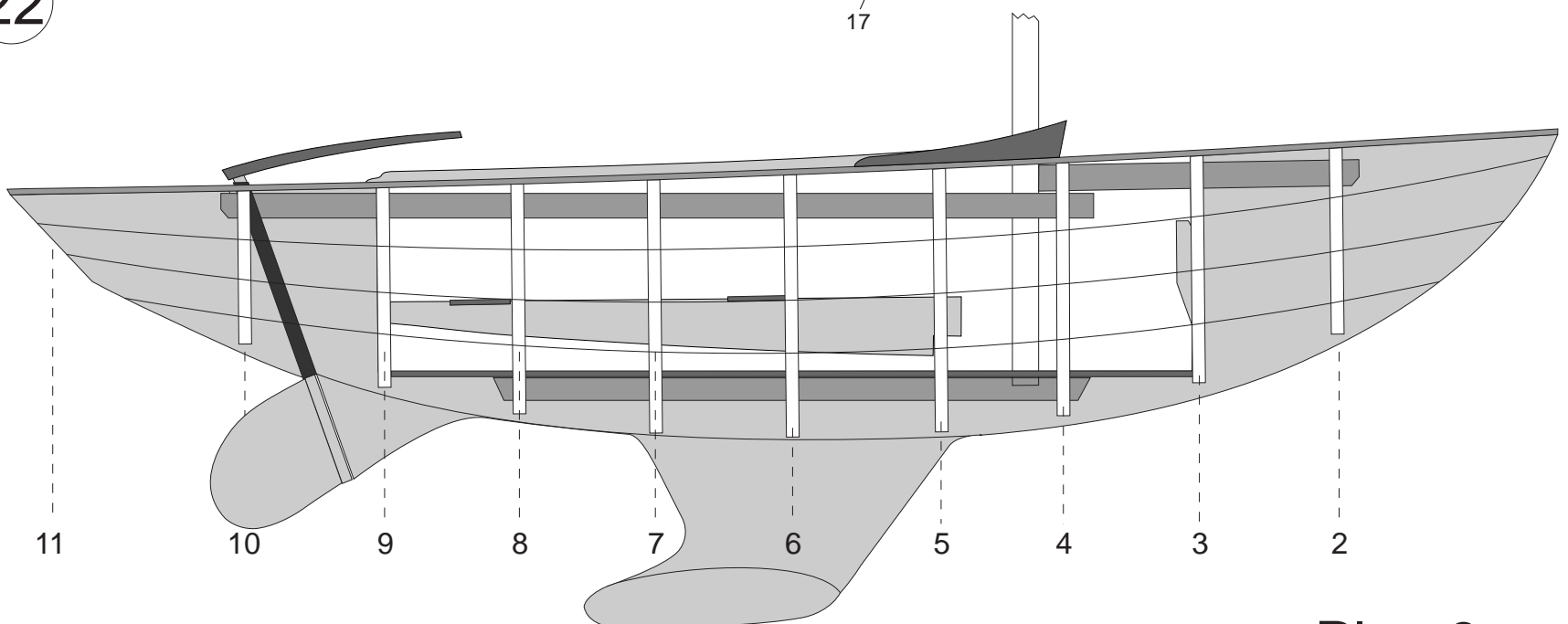

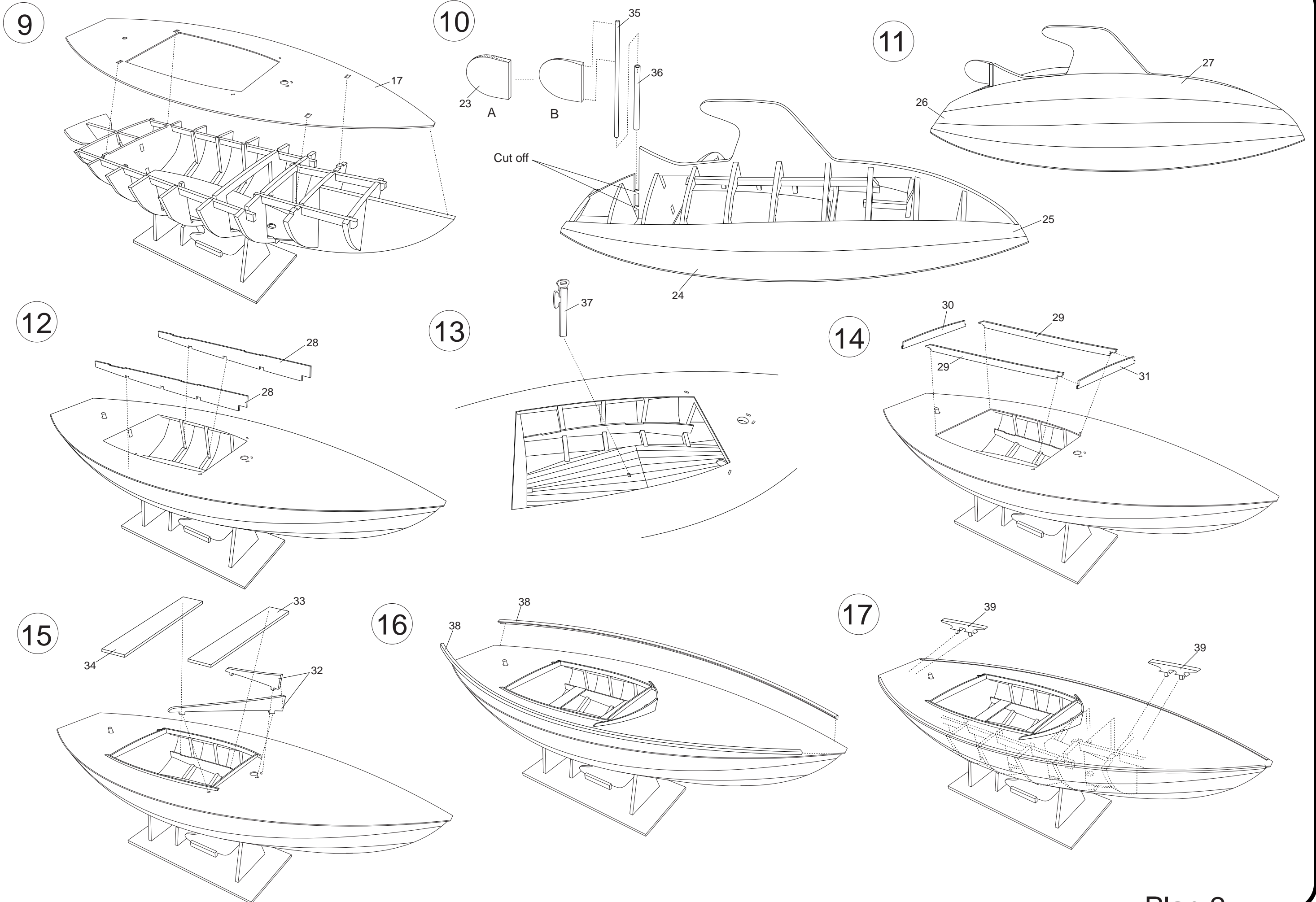

## KILLING PART LIST

NO	ITEM	DESCRIPTION	SIZE	TYPE
1	1	Keel	4 mm	<i>Plywood</i>
2...11	10	Frames	4 mm	<i>Plywood</i>
12-13-14	6	Keel immobilizers	4 mm	<i>Plywood</i>
15	1	Bottom deck	1,7 mm	<i>Plywood</i>
16	2	Release parts	4 mm	<i>Plywood</i>
17	1	Main deck	1,7 mm	<i>Plywood</i>
18...22	6	Base plate parts	4 mm	<i>Plywood</i>
23	1	Rudder	4 mm	<i>Plywood</i>
24...27	8	Side planks	1,7 mm	<i>Plywood</i>
28	2	Cabine inside keel immobilezers	1,7 mm	<i>Plywood</i>
29-30-31	4	Cabine surrounds	1,7 mm	<i>Plywood</i>
32	2	Breakwater	1,7 mm	<i>Plywood</i>
33-34	2	Cabine steps	1,7 mm	<i>Plywood</i>
35	1	Rudder bar	3x93 mm	<i>Metal stick</i>
36	1	Rudder bar pipe	4x57 mm	<i>Metal pipe</i>
37	1	Boom immobilizer part	-	<i>White metal</i>
38	2	Side brackets	L-shaped 460 mm	<i>Mahogany</i>
39	2	Double cleat	-	<i>White metal</i>
40	1	Rudder tiller	Ready	<i>Wooden</i>
41	1	Main sail	Ready	<i>Sail fabriq</i>
42	1	Front sail	Ready	<i>Sail fabriq</i>
43	20	Eyebolt	Ready	<i>Metal</i>
44	-	Rope	-	<i>Yarn</i>
45	4	Double-holed blocks	-	<i>Wooden</i>
46	1	Main post	8x560 mm	<i>Dowel</i>
47	1	Boom	6x170 mm	<i>Dowel</i>
49	1	Nametag	1,7 mm	<i>Plywood</i>
50	2	Nametag legs	1,7 mm	<i>Plywood</i>
51	1	Boom connector part	-	<i>White metal</i>
52	1	Boom connector part	-	<i>White metal</i>
53	1	Nail	-	<i>Nail</i>

## ASISTANT GUIDE

- ❖ Please read the instructions carefully before you start to build your model. Take notes if needed. So, you may find out the materials and the tools those you need.
- ❖ Use model knife to take out the parts the plywood sheets. Do not take them out with hand!
- ❖ Change of temperature effects on plywoods quickly. So that, do not release the plywoods. Keep them on a flat surface by putting weight on them.
- ❖ You may stick together the wooden parts easily if you sand the brown areas caused by laser with sand paper.
- ❖ You should use super glue and white glue to stick together the wooden parts and use the super glue for metal parts.
- ❖ Building the keel of your model, before stick the frames, be sure the frames properly seated on the keel. Otherwise you can't build the body of the model rightly. Exactly be sure that left and right side of the frames are compatible and symmetrical.
- ❖ After building the keel of your model, before the covering, you should test the frame edges by a cover strip. You should sand with a piece of sandpaper the frame edges at the right degree to touch the strips on to the surface exactly. The curves are mostly the front and back side of the body.
- ❖ You should keep the strip tips in the bowl filled with water approximately one hour. So that you may curve the strips on the curves easily these are mostly at the end and the front of the hull.
- ❖ You should cover the strip starting from the top for each side symmetrically.
- ❖ You should cut the upper side of the strip when overlap occurs especially at the front curve of the body.
- ❖ To make equal the surface of the body that caused by planking, you should sand with a piece of sandpaper (Firstly you should use thick sandpaper, then you can apply thin sandpaper), . You should fill the gaps after this processing. You may use leftover strips for wide gaps and model putty for small gaps.
- ❖ If you don't want to appear wooden tissue of the body of your model body; first, apply filler undercoat then sand with a thin sandpaper to make it ready to apply putty. Apply putty whole body and sandpaper again. Apply one more coat filler undercoat and sandpaper. You should not use very thick sandpaper to sand the putty and filler undercoat. You should repeat this process until you get the results as you want. You should apply undercoat paint to find out if any mistake appears at the body. The body gets ready for painting after these applications. You may use model brushes for filler coating. In order to understand whether the materials (such paint, filler, undercoat, varnish, etc.) are compatible with each other, you should test on the unnecessary parts.
- ❖ Some of the model's logo, name or the number are produced from decal paper. You should keep them in a bowl filled with warm water for two or three minutes. You should apply them to their places while releasing from their paper. You may attach easily If you apply gloss varnish to the place before applying the decals. You may apply matt, gloss or satin varnish after this application preferably.
- ❖ You should keep your model away from direct sunlight, heat and moist to avoid deformation in the course of time.