

10...Windshield & Body Installation

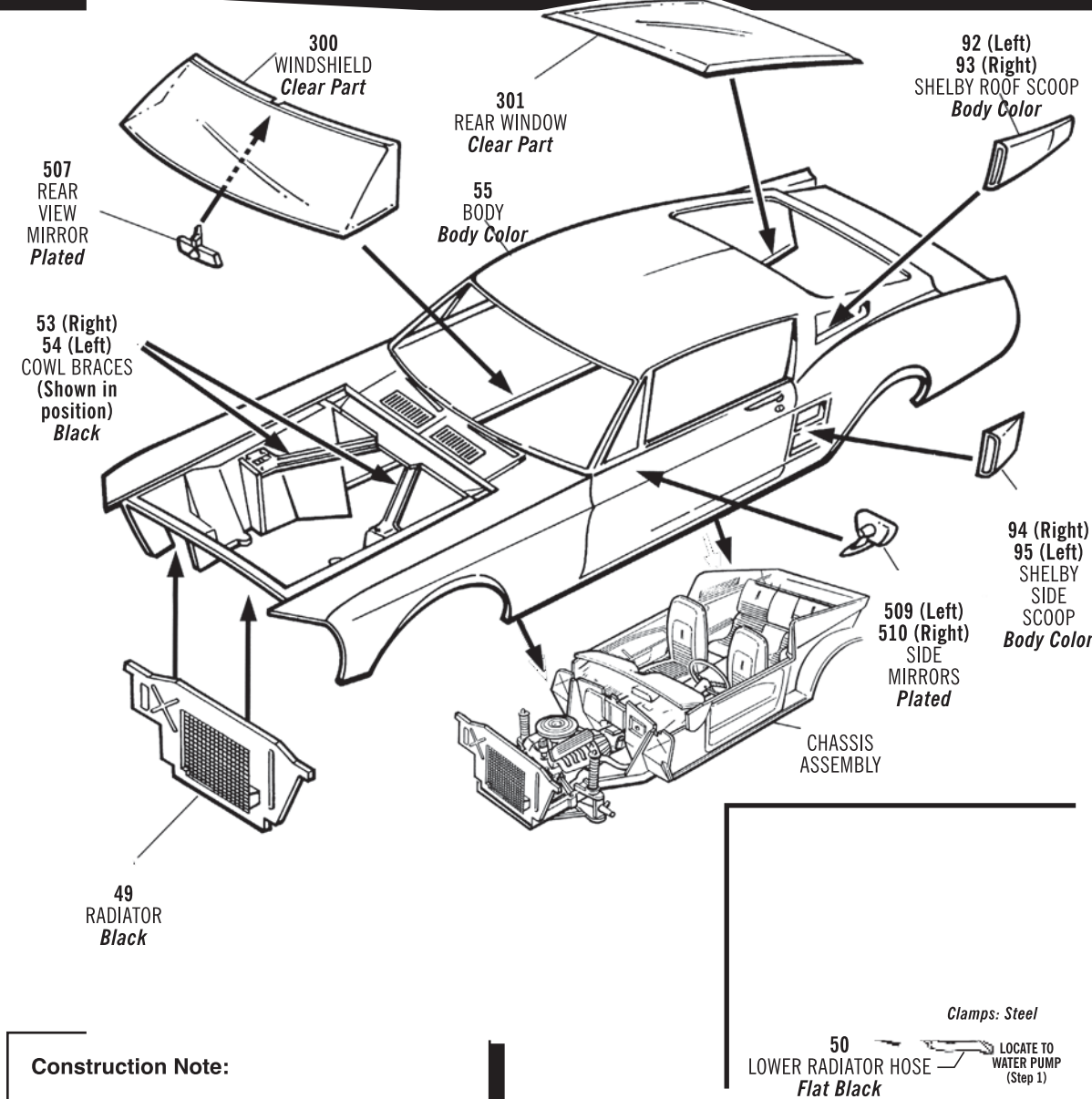

Construction Note:

- 1...Cement 53, 54 Cowl Braces into position. Note that the ends locate under the rear edge of the hood opening.
- 2...Cement 507 Rear View Mirror to 300 Windshield.
- 3...Cement 300 Windshield and 301 Rear Window to 55 Body. These cement to the inside of the body.
- 4...Place Body Assembly onto the Chassis Assembly. Make sure front spring/ shocks locate correctly.
- 5...Cement Scoops and Side Mirrors in place.
- 6...Cement 49 Radiator and 50 Lower Radiator Hose (see inset diagram) into position before Body/ Chassis Assembly.

11...Front End Assembly

Construction Note:

- 1...Cement 320 Headlight Lenses to 531 Headlight Housings. Make 4 assemblies. Remember to scrape the plating from the Housings where cement will be applied before cementing.
- 2...Cement Headlight Assemblies into 90 Front Fascia.
- 3...Cement 311 Parking Light Lenses into 90 Front Fascia.
- 4...Cement 532 Front Bumper to 90 Front Fascia. Scrape plating from locator pins on Bumper before cementing.
- 5...Cement 59 License Plate to 90 Front Fascia.
- 6...Place 91 Hood in position.
- 7...Cement 52 Battery and 51 Upper Radiator Hose in place.

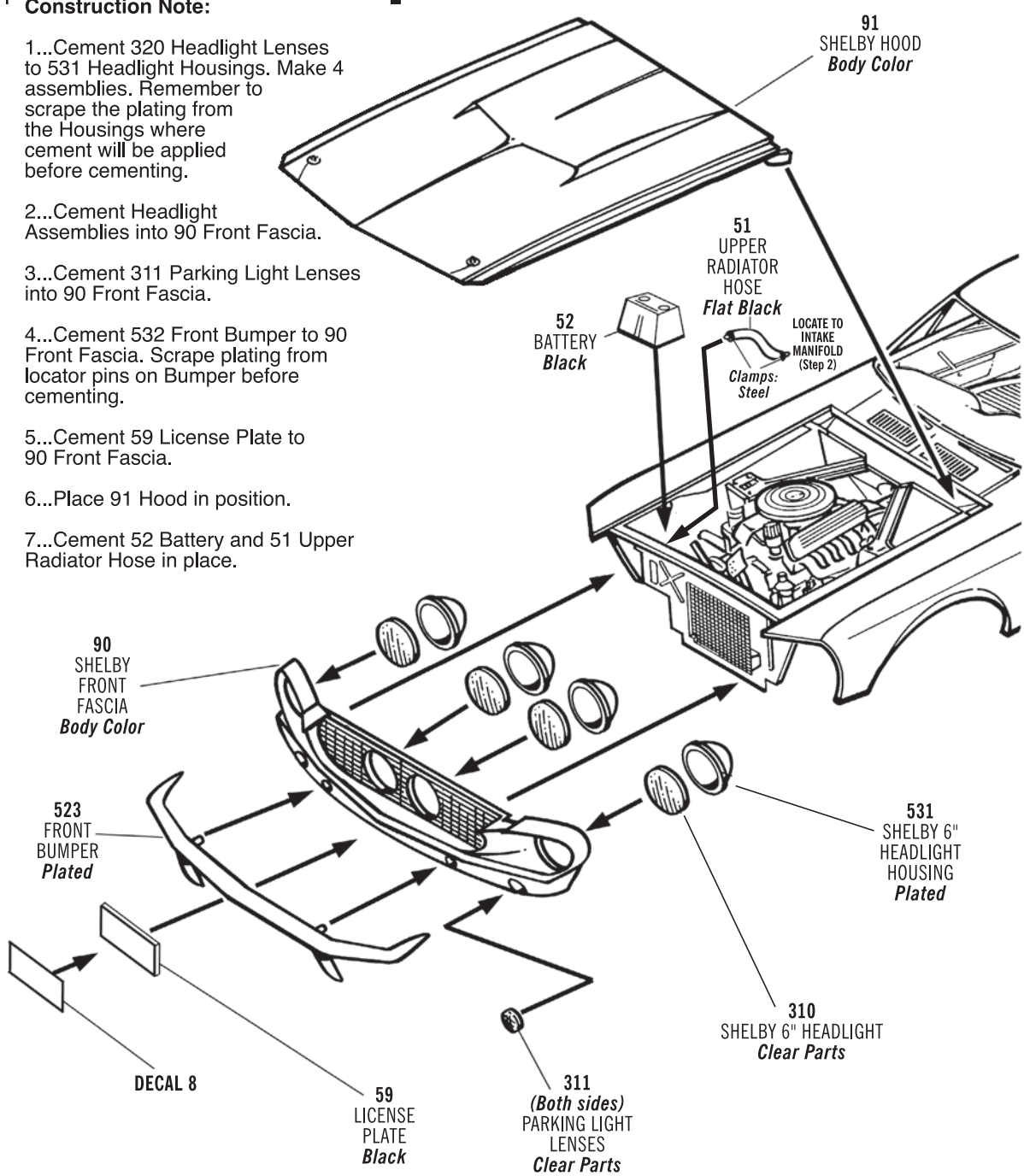

12...Rear Fascia Assembly

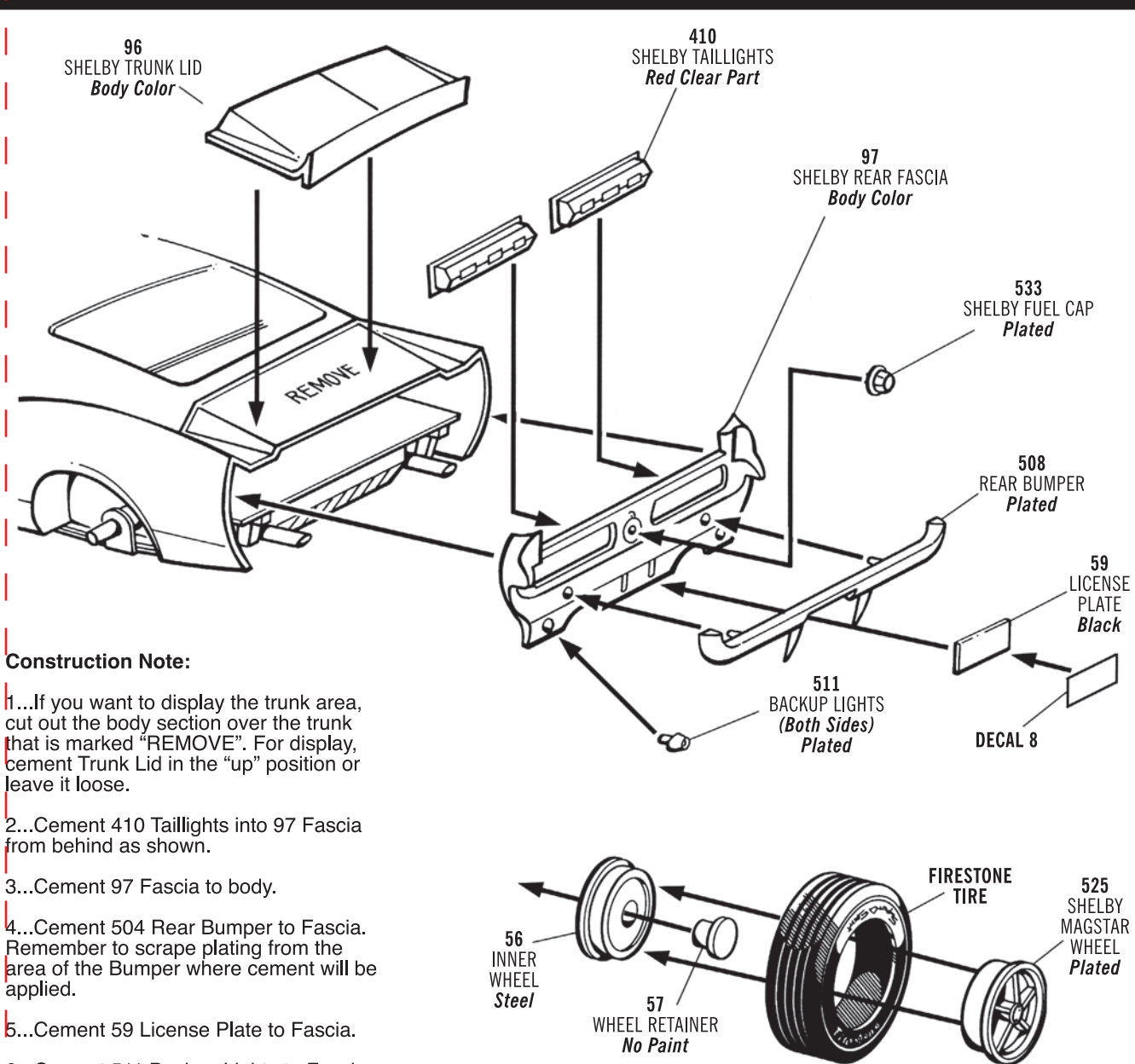

Construction Note:

- 1...If you want to display the trunk area, cut out the body section over the trunk that is marked "REMOVE". For display, cement Trunk Lid in the "up" position or leave it loose.
- 2...Cement 410 Taillights into 97 Fascia from behind as shown.
- 3...Cement 97 Fascia to body.
- 4...Cement 504 Rear Bumper to Fascia. Remember to scrape plating from the area of the Bumper where cement will be applied.
- 5...Cement 59 License Plate to Fascia.
- 6...Cement 511 Backup Lights to Fascia. Scrape plating away before cementing.
- 7...Cement 533 Fuel Cap to the Fascia. Scrape the plating from the area to be cemented.
- 8...Cement 96 Trunk Lid into position on the body.

Construction Note:

- 1...Slip 57 Wheel Retainer into 56 Inner Wheel. DO NOT USE ANY CEMENT.
- 2...Push 56 Inner Wheel into Tire. Make sure 57 Wheel Retainer stays in position.
- 3...Apply cement sparingly to back side of 525 Magstar Wheel after scraping plating off rear to be cemented.
- 4...Push 525 Wheel into tire and into contact with 56 Inner Wheel. Let dry.
- 5...Apply cement sparingly to each axle. Press a wheel assembly onto each axle.

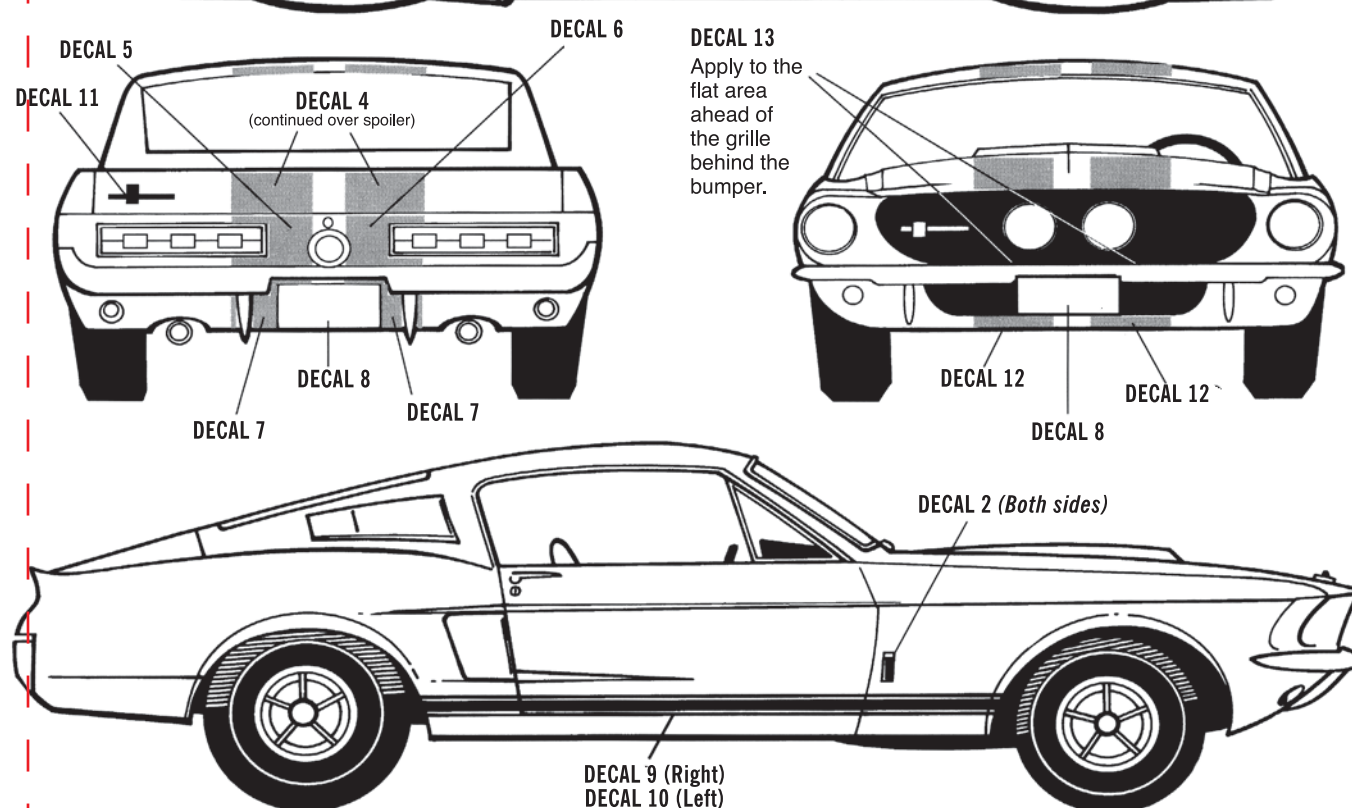
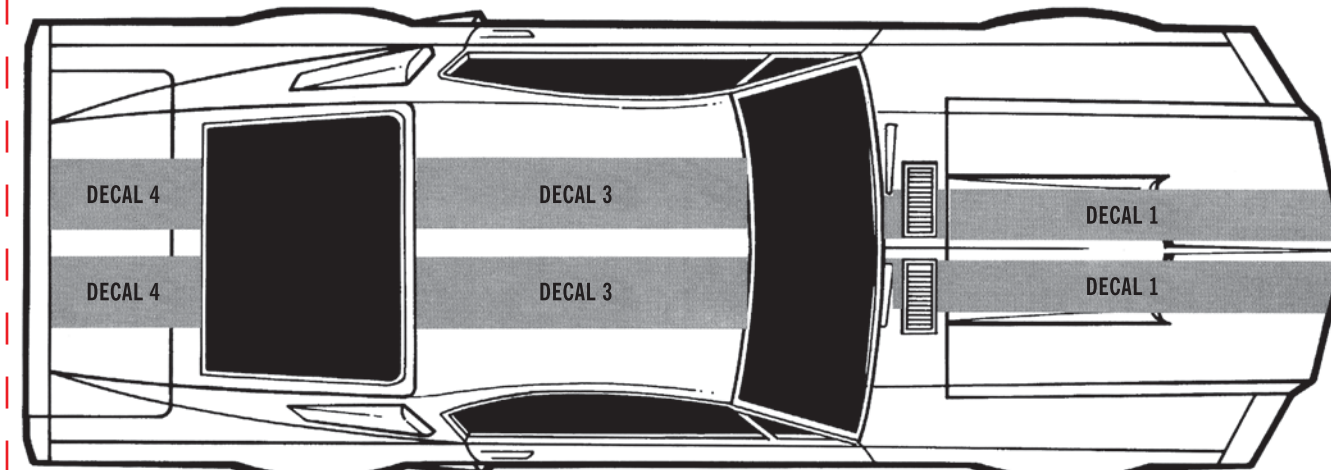

Powered by a race-proven Shelby tuned High Performance 289 Ford engine and decked out externally with things like side-of-roof and quarter panel air scoops, trunk lid spoiler, custom hood with air scoop, high beam headlights mounted in the center of the grille, rollbar, and special Magstar wheels, the '67 Shelby GT-350 was not your average Mustang.

Fiberglass custom parts which included the lengthened hood, custom air scoops, front fascia, and truck deck not only added to the elan of the car but lightened it by many pounds.

Stock Mustang bumpers were used front and rear but '67 Cougar taillights were mounted in the rear.

Ford, in order to capture a wider segment of the buying public, dressed the '67 Mustang and thereby the '67 Shelby GT-350 had serious comfort items which included the Deluxe Mustang interior, power brakes, power steering, optional air-conditioning, and optional automatic transmission.

Driving a Shelby GT-350 in 1967 put you in the elite of the performance motoring public.

Performance:

- 0-60.....7.1 seconds
- 1/4 mile.....91 mph in 15.3 seconds
- Top speed.....129 mph

IMPORTANT

Before you begin to assemble your model kit, study the instructions carefully. This will help you to familiarize yourself with the part locations as you proceed. Prior to cementing parts together, be sure to "TEST FIT" them in order to assure proper alignment and also to check for excess "FLASH" that may occur along parting lines. Use a sharp hobby knife or file to remove flash if necessary.

If you wish to paint your model, various sub-assemblies and components should be painted before any parts are attached. During assembly, you may note that the recommended color is stated after the part name.

This model kit is molded from the finest high-impact styrene plastic. Use only paints and cements which are specifically formulated for styrene. Read all labels and warnings carefully.

Because the cement will only adhere to bare plastic, it is necessary to remove any paint or "plating" from the area to which the cement is to be applied.

BUILDING TIPS FOR THE ADVANCED MODELER

For the best possible finish, your kit should be painted, even if molded in color. Paint should be applied evenly, in several thin coats rather than one heavy coat. The first coat should not completely cover the surface. Each layer should be allowed to thoroughly dry before the next is applied. Also, each coat should be "wet sanded", except for the final coat, using No.1200 wet or dry sandpaper which is slightly damp. Be careful not to remove any detail while sanding.

It is important to keep your hands clean when working with your model. Wash parts thoroughly before painting to remove any mold release agent that may have been used during manufacture, body oil from your hands, sanding residue, and dust, which is naturally attracted to plastic by static electricity. Use a mild solution of dishwashing detergent and water. A tack rag should be used to dry the parts, DO NOT use paper towels or tissues, since they will leave lint on the part.

Parting lines and glue joints should be sanded or filed prior to painting and cementing. Because paint has a tendency to draw away from sharp edges, they should be lightly filed. Use filler putty designed for plastic to fill small gaps that may occur between parts and to blend contours. This should be done only after the first, or "primer," coat of paint is applied.

When painting a two-tone body, the lightest color should be painted first. Use frosted, or "magic," tape to mask off the area you do not want painted. After the second color is dry to the touch, the tape can be removed. Use a very fine brush to touch up edges if necessary. If decals are to be added, do so before adding any gloss coat. A gloss coat will help even out the edges between the two colors as well as set the decals.

RECOMMENDED TOOLS

HOBBY KNIFE

Use a sharp hobby knife to remove parts from the trees. The knife may also be used to remove parting lines and flash.

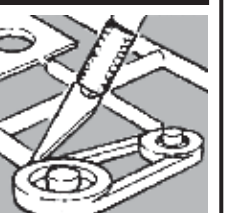

TWEEZERS

Use tweezers to hold small parts during assembly, painting and when applying cement.



BRUSH

We recommend the use of liquid polystyrene cement. Apply with a fine brush. Use sparingly or a sloppy job will result.

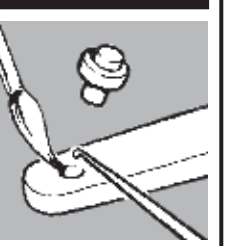

READ ALL LABELS AND WARNINGS CAREFULLY

United States Postal Service® and stamp art is used with permission under license to Round2Models, LLC. © 2022 United States Postal Service. All rights reserved. SHELBY®, CARROLL SHELBY'S PHOTOGRAPH, LICENSE & VOICE™, GT-350™, THE SHELBY MODIFICATIONS TO CREATE THE SHAPE AND DESIGN OF THE 1967 SHELBY GT-350 VEHICLE™ are registered trademarks and/or the trademarks of Carroll Shelby and Carroll Shelby Licensing, Inc. (Shelby). COBRA and the COBRA SNAKE Design are trademarks of Ford Motor Company used under license. Firestone and F. Schlegel are registered trademarks of BF Goodrich, LLC and are used with permission. AMT and design are trademarks of Round 2, LLC. ©2022 Round 2, LLC, South Bend, IN 46828 USA. Product and packaging designed in the USA. Made in China. All rights reserved.



SEE MORE GREAT AMT KITS!
VISIT US ONLINE AT...

round2models.com



1...Basic Engine Assembly

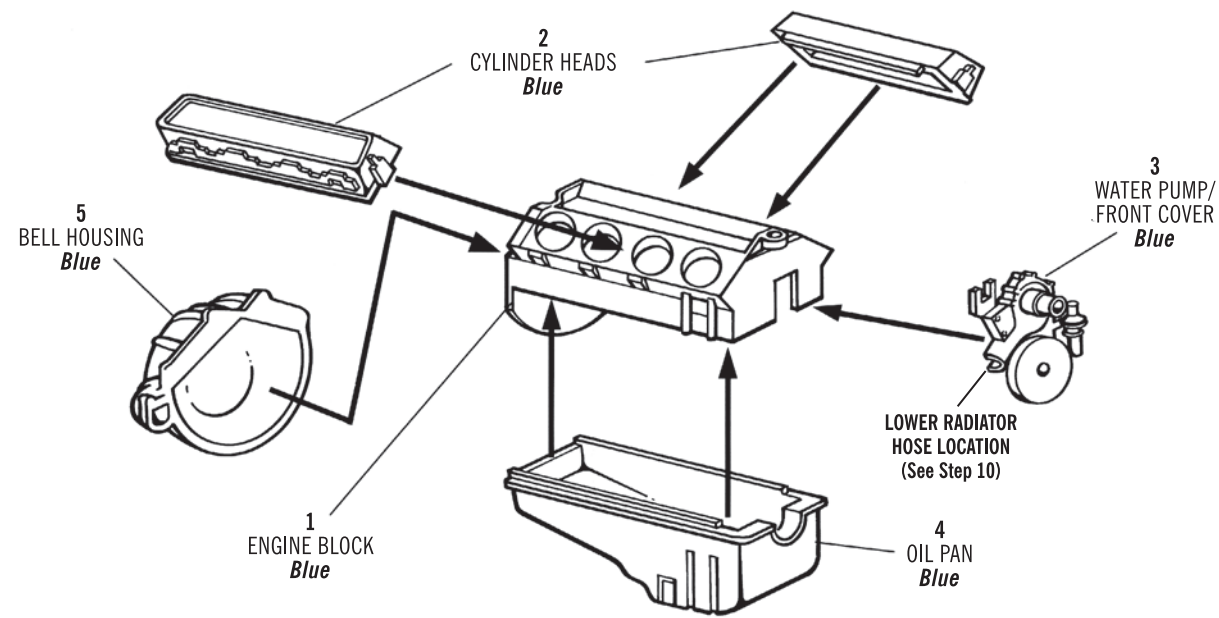

2...Intake & Front Case Accessories

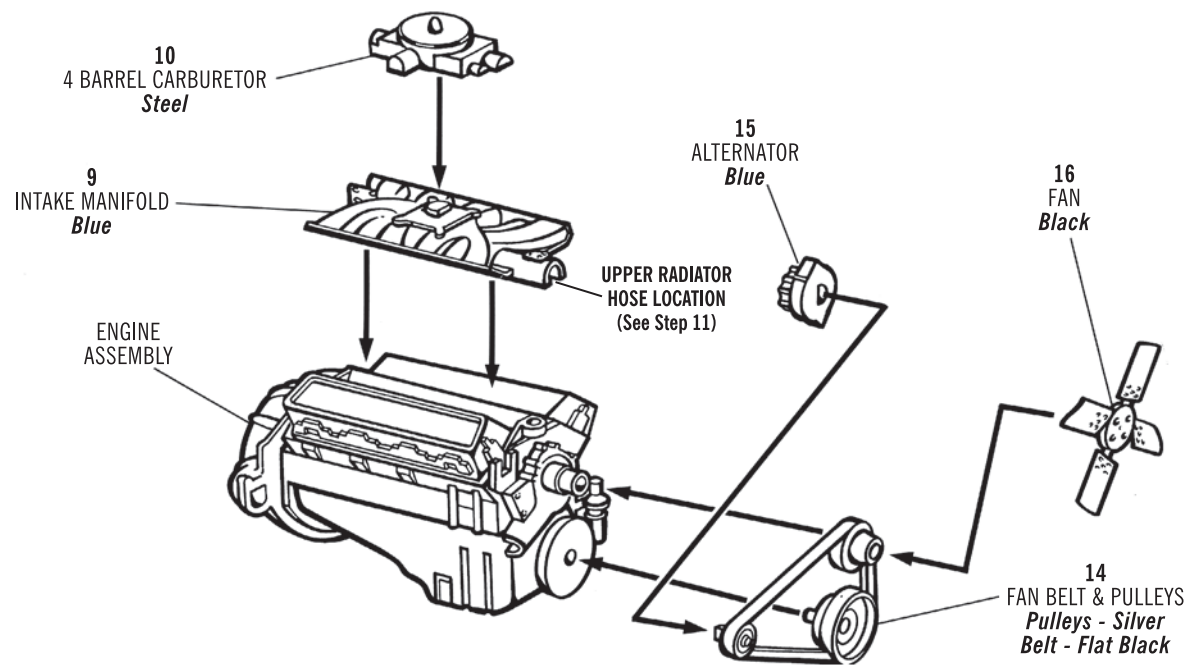

3...Valve Covers, Coil & Starter Installation

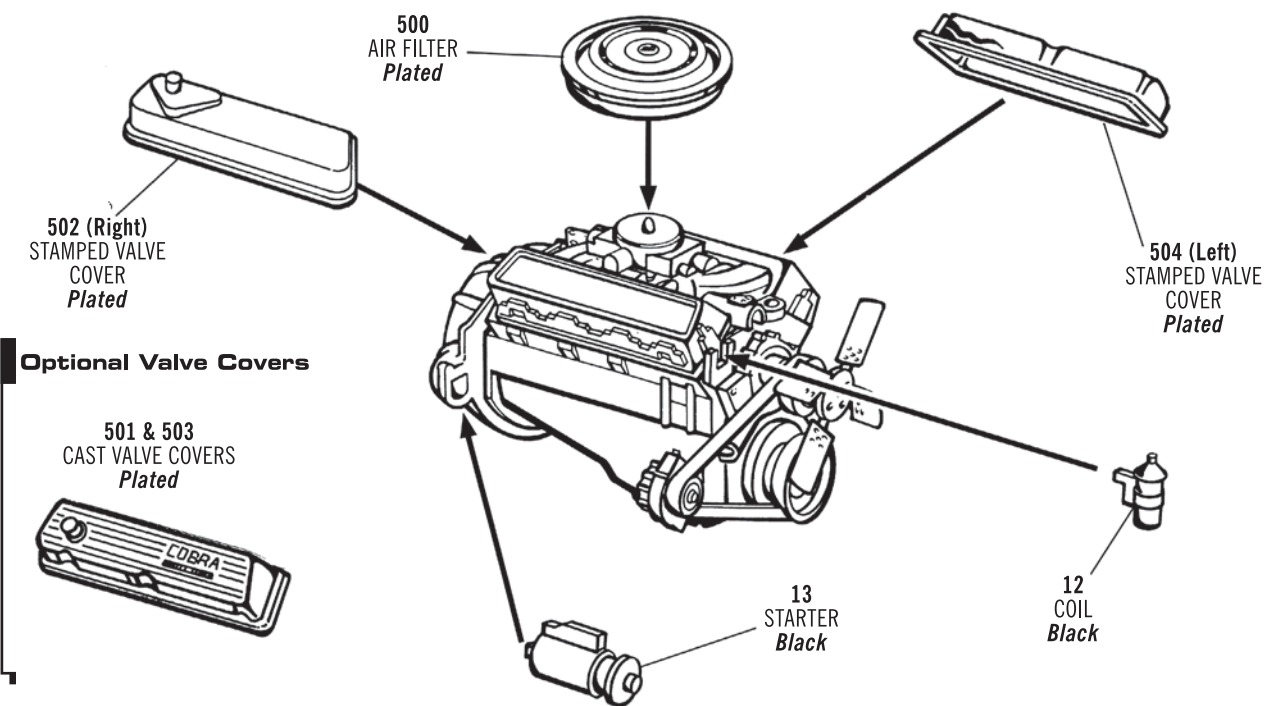

4...Transmission & Exhaust Manifold Installation

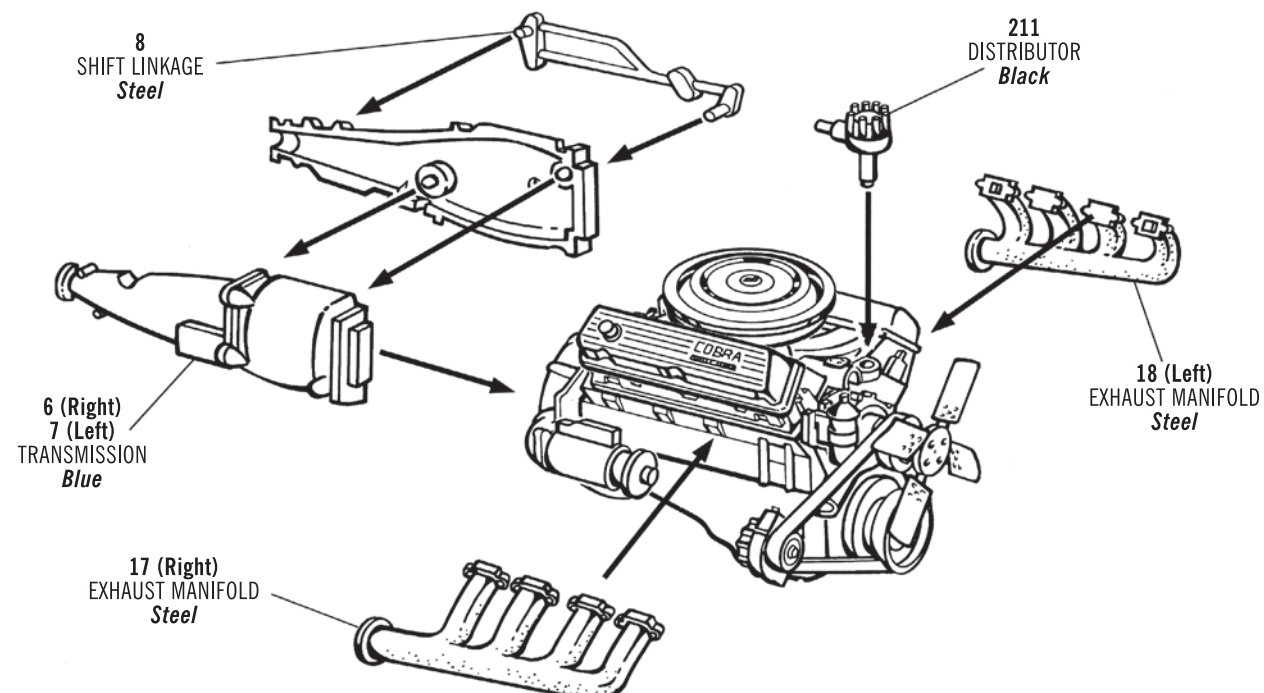

5...Front Suspension & Steering Assembly

Construction Note:

- 1...Cement 21, 22 Spindles to Chassis as shown.
- 2...Cement 20 Front Axle to Spindles and Chassis as shown.
- 3...Cement 23 Steering Linkage to Spindles and Chassis as indicated.
- 4...Cement 24 Shock Absorbers to Chassis as shown.
- 5...Cement 505 Disc Brakes onto axles.

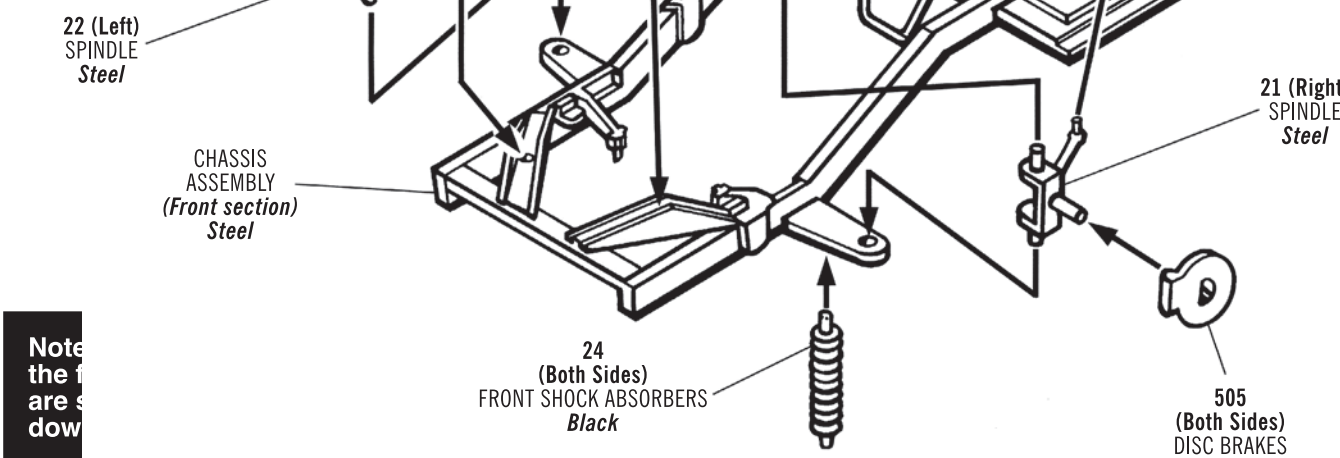

6...Rear Suspension & Exhaust Assembly

Construction Note:

- 1...Cement one end of 32 Driveshaft to rear of Transmission. The other end of the Driveshaft will be cemented to the Rear Axle in Step 7.
- 2...Cement 27, 28 Axle halves together.
- 3...Cement 27, 28 Axle to 29 & 30 Leaf Springs.
- 4...Cement 25 Exhaust System to 26 Tailpipes.
- 5...Cement 25, 26 Exhaust Assembly to Chassis as shown.
- 6...Cement the forward ends of 25, 26 Exhaust Assembly to the rear of the engine exhaust manifolds.
- 7...Cement Axle/Springs Assembly to Chassis. Cement the rear end of the Driveshaft to Axle/Springs at this time.
- 8...Cement 530 Shelby Exhaust Tips to the rear ends of 25, 26 Exhaust System.
- 9...Cement 31 Shock Absorbers to Chassis and to Rear Leaf Spring brackets as shown.
- 10...Cement one 58 Brake Drum to each end of the 27, 28 Rear Axle.

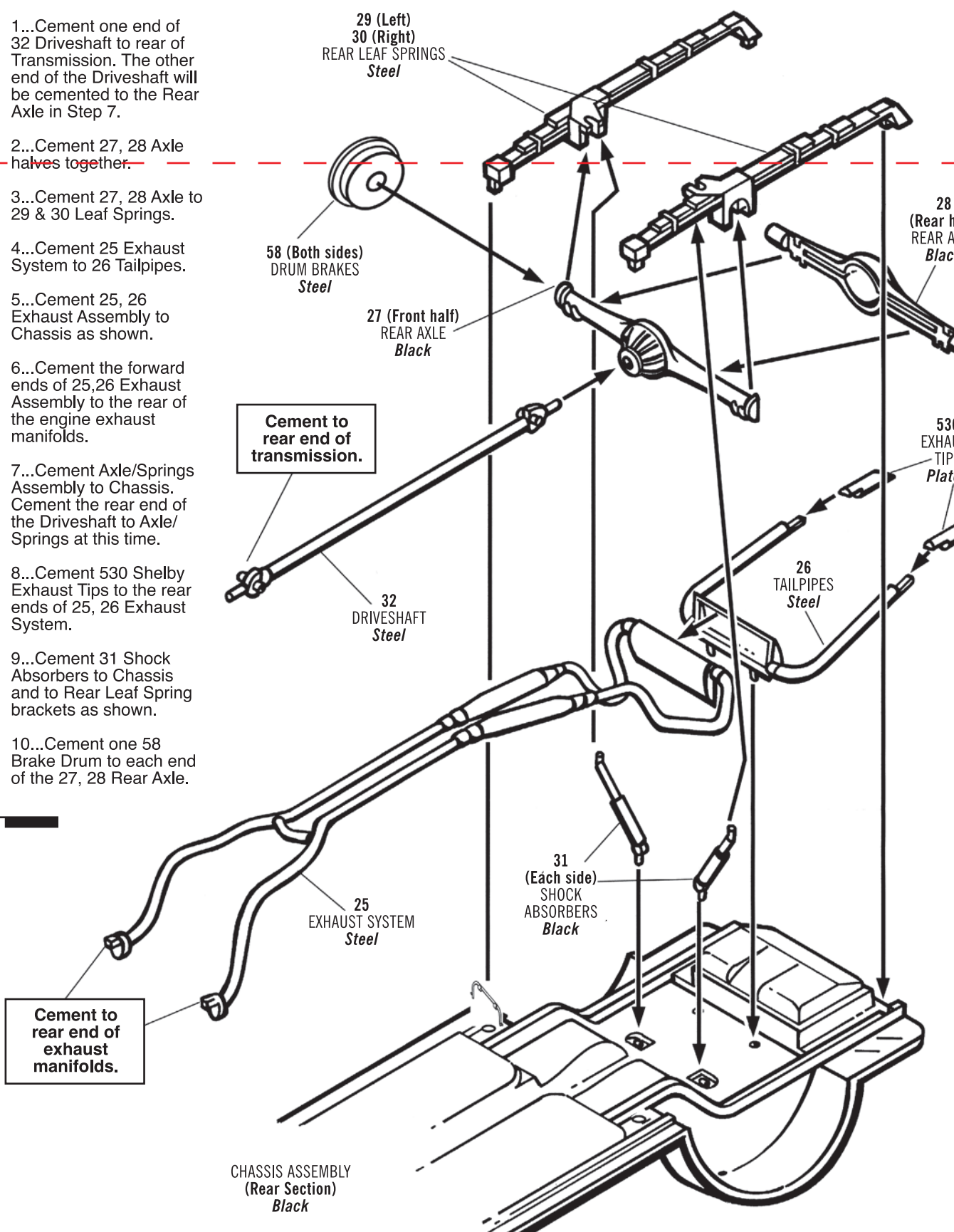

7...Front Seats & Firewall Installation

Note:

Make 2 Bucket Seat (41 & 40) assemblies.

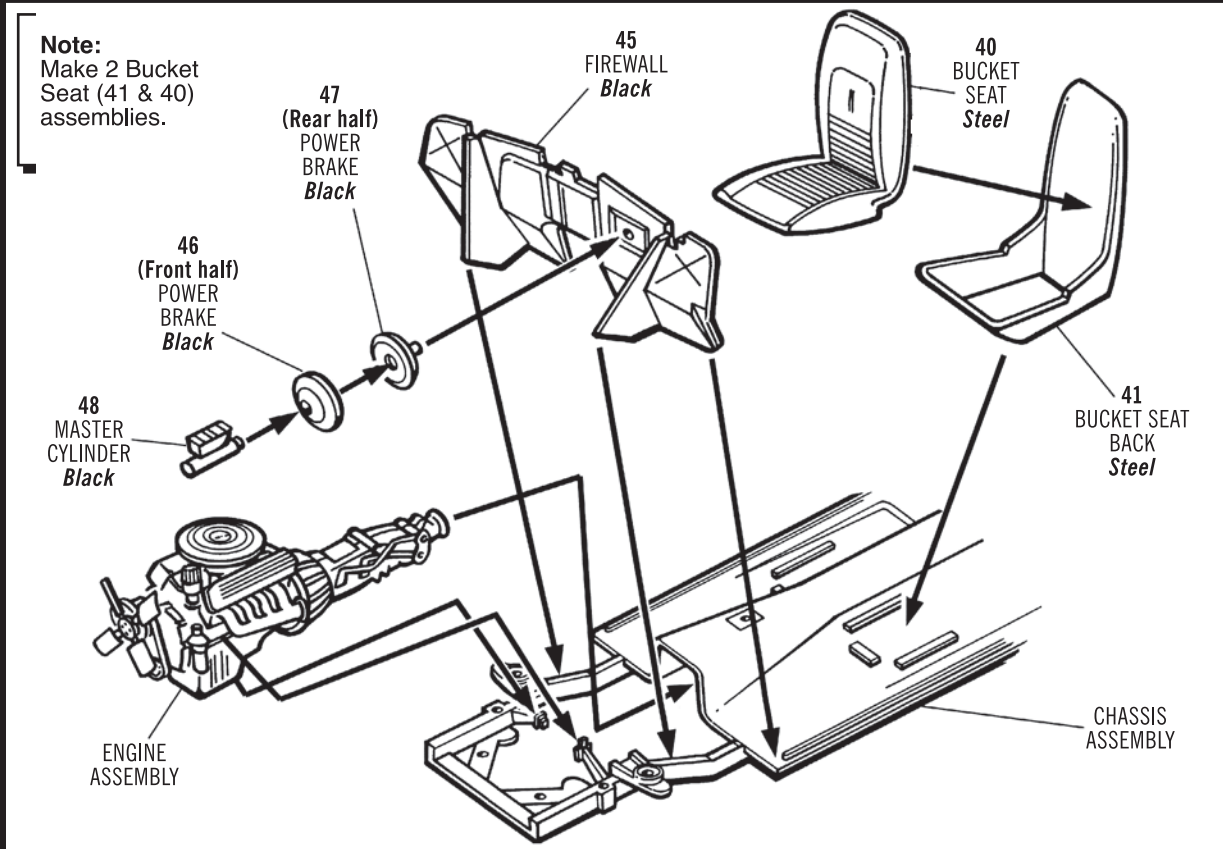

8...Rear Seat & Interior Installation

Construction Note:

- 1...Cement 34 Side Panel to Chassis as shown. Cement 35 Side Panel (not shown) to left side of chassis.
- 2...Cement 38 Interior Back Panel between Side Panels.
- 3...Cement 36 Seat Cushion to Chassis. Center transmission hump on seat to hump on chassis.
- 4...Cement 37 Seat Back to top of Seat Cushion and to Side Panels.
- 5...Cement 39 Rear Seat Back to the top rear lip of 37 Seat Back.
- 6...Cement 44 Trunk Floor into position.
- 7...Cement 506 Shift Lever to transmission tunnel as indicated. Remember to scrape plating from Shift Lever, in the area where you will be applying the cement, before cementing it to the chassis.
- 8...Cement 100 Roll Bar into place. Use your hobby knife to open holes in Side Panels where shown.

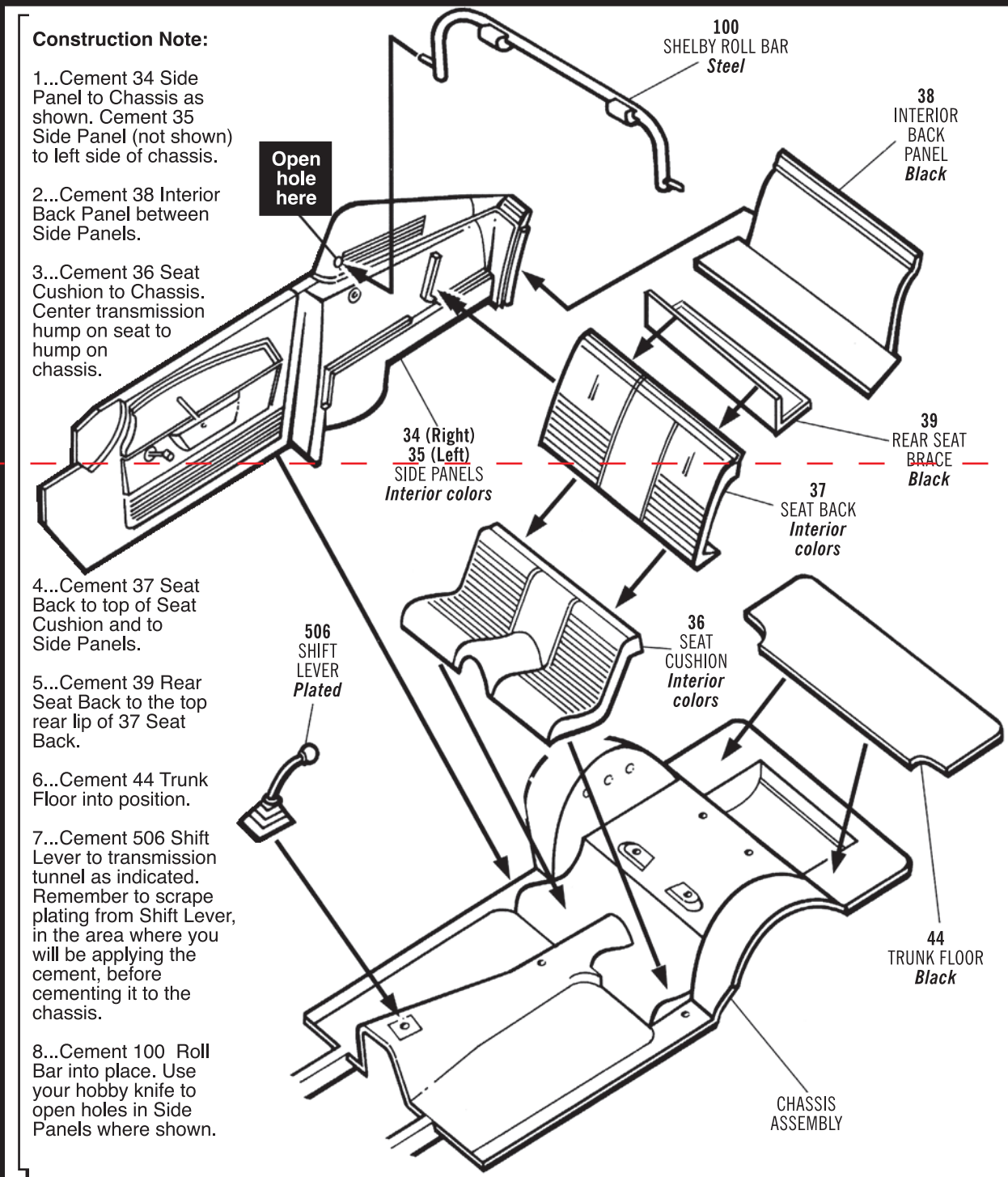

9...Instrument Panel Assembly & Installation

