

GECKO - Stern Windlass

600W / 900W



This new stern windlass features horizontal configuration for easy installation in the stern of the boat inside the anchor locker compartment, keeping the boat's appearance unaffected.

The dimensions and the compact design of the windlass allows installation which needs very limited space, as the motor/gearbox can rotate up to 180° at 60° increments.

Available in two different configurations, for installation in the port or starboard side of the transom. Each unit is equipped with a handle, rope guide, pressure finger and control box.

Main features

- ✓ IP67 protective cover for the motor
- ✓ Anodised marine aluminium gearbox
- ✓ Automatic free fall operation with the push of a button
- ✓ Automatic stop function for carefree anchoring
- ✓ Compact design
- ✓ Easy installation
- ✓ Italian design

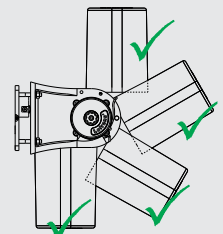

The motor can be installed in various positions.

The new model is available in 2 motor versions, 12V 600W and 900W providing the following specs, which make it an ideal anchoring system for vessels from 20 to 45 feet:

Stern Windlass Technical Specifications

Code	636645	636633
Wattage (W)	600	900
Power Supply (V)	12	12
Maximum Pull (kg)	630	700
Working Load (kg)	95	125
Amps at Working Load (A)	65	80
Line Speed at Working Load (m/min)	18	20
Max Line Speed (m/min)	24	25
Circuit Breaker (available separately)	187331	187332
Control Box / Direction Solenoids	Included in the package	Included in the package

For use with 12/14/16 mm 3-strand or leaded rope

Dimensions in mm

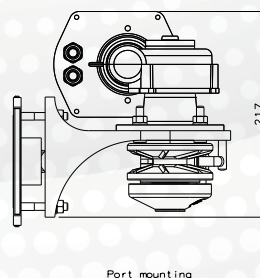
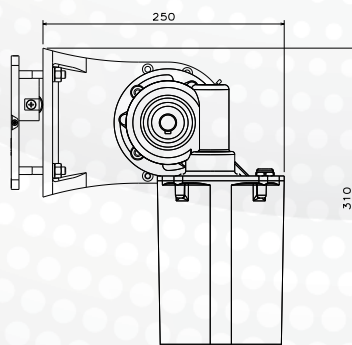
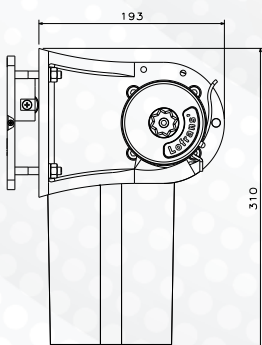

Port mounting

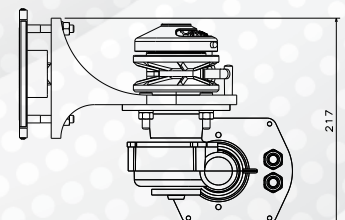

Starboard mounting