

Verricelli Orizzontale

Horizontal Windlasses

CONSERVARE QUESTO MANUALE A BORDO
STORE THIS MANUAL ON BOARD
CONSERVER CE MANUEL A BORD
DIESES HANDBUCH AN BORD AUFBEWAHREN
GUARDAR ESTE MANUAL A BORDO

MANUALE DI INSTALLAZIONE E D'USO - INSTALLATION AND USER'S MANUAL
MANUEL D'INSTALLATION ED D'UTILISATION - MANUAL DE INSTALACIÓN Y USO
INSTALLATION UND BEDIENUNG

LION 1000 - Cayman 88 - Tigres - Falkon

UK



LION 1000

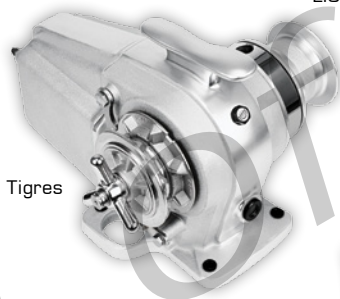

Tigres



Cayman 88

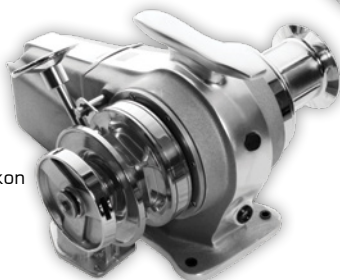

Falkon

Lofrans!
WINDLASSES
THE ORIGINAL WINDLASS



Via Philips, 5 - 20052 Monza (MB) (Italy)
www.lofrans.com - e-mail: contact@lofrans.com



Dear Customer,

Thank you for choosing a Lofrans' product. Lofrans' is a leader company in the production and worldwide distribution of nautical systems manufactured according to the most modern technologies, in compliance with international regulation requirements and the most important certifying bodies. All our products are manufactured with excellent materials suited for operations in marine environments and are subject to continuous checks to improve the qualitative levels and make them without any manufacturing defects. Together with such requirements, Lofrans' anchor windlasses are a synthesis of reliability and efficiency, by guaranteeing the maximum performances during each phase of mooring, even in the most difficult. With a Lofrans' product, years of reliable operations are guaranteed.

Lofrans'©copyright, 2023. All rights reserved.

Lofrans' declines any liability for possible inaccuracies due to print errors in this manual and reserves the right to introduce any changes deemed appropriate.

For this reason, Lofrans' does not guarantee the accuracy of the manual after the date of issue and declines all liability for possible errors and omissions.

TABLE OF CONTENTS

1 INTRODUCTION _____	3	6 MAINTENANCE _____	13
1.1 Purpose of the manual _____	3	6.1 Maintenance programme _____	13
1.2 Assistance _____	3	6.2 Gipsy maintenance/replacement _____	14
1.3 Receipt and storage _____	3		
2 SAFETY INFORMATION _____	3	7 TROUBLESHOOTING _____	14
3 INSTALLATION _____	4	8 TECHNICAL DATA _____	17
3.1 Contents of the package _____	4	9 SPARE PARTS _____	19
3.2 Equipment necessary for installation _____	4	10 OVERALL DIMENSIONS _____	27
3.3 Recommended accessories _____	4	11 WARRANTY CONDITIONS _____	31
3.4 General requirements for installation _____	4	11.1 Conditions and limits _____	31
3.5 Prevention from electrolysis _____	5	11.2 Exceptions _____	31
3.6 Deck installation _____	5	11.3 Liability _____	31
4 ELECTRICAL SYSTEM _____	6	11.4 Procedure _____	31
4.1 Electrical cable section _____	6	11.5 Clause of Termination _____	31
4.2 Solenoid valves (Control Box) _____	6	11.6 Compliance _____	31
4.3 Circuit breakers _____	6		
4.4 Remote control electric panel board _____	6		
4.5 Protection of electrical components _____	6		
4.6 Wiring diagram _____	7		
5 USE OF THE WINDLASS _____	11		
5.1 Lowering the anchor _____	11		
5.1.1 Lowering the anchor Electrically _____	11		
5.1.2 Lowering the anchor by gravity _____	11		
5.2 Weighing the anchor _____	12		
5.3 Use of the manual override _____	12		
5.4 Use of the warping drum _____	12		
5.5 Notes for use _____	13		

PRODUCT COMPLIANT WITH CE REGULATIONS

1 INTRODUCTION

1.1 Purpose of the manual

This manual will supply information on safety and correct use of the product. Follow these warnings carefully to avoid possible accidents or damages.

DANGER!

A warning such as this indicates the existence of a serious risk that has high probabilities to cause death or a serious accident if appropriate precautions are not taken.

ATTENTION!

A warning such as this indicates a reference to the application of safety practices, or draws the attention on unsafe behaviours that might cause personal injuries or damages to the boat.

1.2 Assistance

The Lofrans' products are backed throughout the world by a network of authorised distributors and assistance. In case of need, please contact your local Lofrans' distributor. Details on website www.lofrans.com

1.3 Receipt and Storage

Upon receipt of the package, verify the integrity of packing. Should it be necessary to store the product for a prolonged period, keep it in a dry and protected place.

2 SAFETY INFORMATION

Safety standards and certifying bodies require peremptorily that, during the standing of the anchor, the load must be held by a chain stopper or a high resistance fixing point.

The user is responsible for guaranteeing that during navigation the anchor is properly stowed and fixed. This precaution is more important when the navigation speed is higher and sea conditions are worse. Indeed, an anchor paid out by mistake during navigation can have very serious effects. Considering its position and not always frequent use, the anchor windlass is particularly exposed to oxidation and corrosion risk; therefore, it is necessary to arrange a constant inspection of its parts and a due maintenance.

Make sure to have read and understood every part of this manual before proceeding with installation and use. Only persons who know how to operate should be authorised to use the anchor windlass. Should there be doubts on its installation or use, refer always to a skilled consultant.

- Anchor windlasses used in an appropriate way can cause damages to persons and/or things.
- Pay the utmost attention during the use of powerful equipment.
- Do not put your hands near the windlass when there is power on the unit.
- Even the most careful use can be a source of damages, even serious.
- Lofrans products are supplied exclusively for recreational nautical use. Lofrans declines all responsibility for improper uses.
- Pay the utmost attention so that arms, legs, fingers, hair, and clothes do not get entangled in the chain or gipsy.
- Before operating the capstans, make sure that there are no persons in water in the vicinity.
- When the capstan is not used, the anchor must always be fixed to a solid point in order to avoid damages.
- The anchor windlass must never be used as mooring point. The load must always be held by a specific leat or solid point.
- The capstan must not be used for functions other than paying out or weighing the anchor.
- The chain must never be used on the warping drum.
- The system must always be protected by a suitable circuit breaker.
- Disconnect always the circuit through the circuit breaker when the anchor windlass is not in use.

3 INSTALLATION

3.1 Contents of the package

In addition to the present manual, the package contains:

- ✓ Anchor windlass
- ✓ Control box
- ✓ Handle

3.2 Equipment necessary for installation

- ✓ Drill
- ✓ 10 mm bit for wood and steel
- ✓ 10 mm., 13 mm., and 17 mm. hexagon keys

3.3 Recommended accessories

Use exclusively original Lofrans accessories and spare parts, designed and manufactured to ensure performances, duration and for keeping valid the warranty. For information on available spare parts, contact your local reseller or visit website www.lofrans.com.

3.4 General requirements for installation

In order to operate the anchor windlass correctly, it must be installed to meet the following conditions:

- 1 ± Bow roller height: it must be such to guarantee a chain inclination lower than 90 degrees.
- 2 ± The parallelism between deck floors must be guaranteed; should it not occur, duly compensate the difference.
- 3 ± Chain locker depth: the chain fall into the chain locker must be such that when the chain is completely stored, there must be a minimum of 300 mm. between the underside of the deck and the top of the heaped chain.

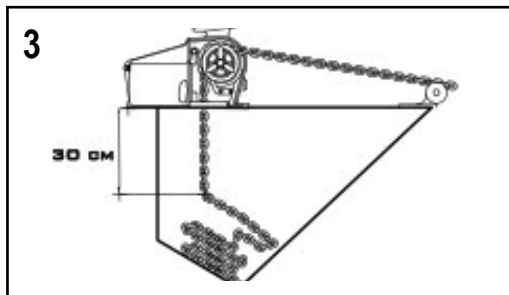
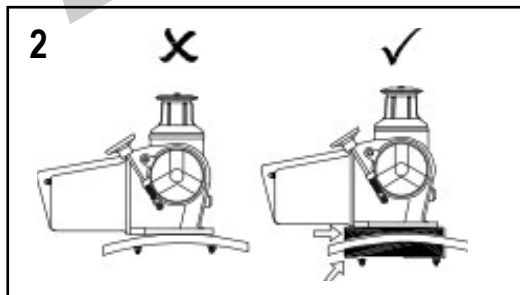
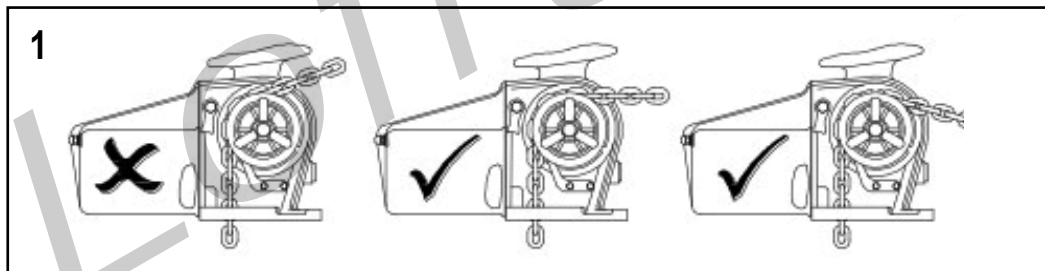

Non-observance of these requirements will cause the malfunctioning of the anchor windlass and voidance of warranty.

3.5 Prevention from electrolysis

Make sure that the anchor and chain are insulated from the hull, including chain locker and fixing systems.

For motors with 2 terminals (LION 1000, CAYMAN with 700W motor), the installer must ground the windlass by connecting a bonding wire to the cathodic protection on board.

For aluminum boats, all windlasses must be insulated from the deck through a non-conductive gasket (not supplied).

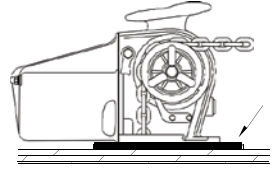

 Without these precautions, the electrolysis phenomenon will lead to a rapid corrosion of the anchor windlass.

3.6 Deck installation

1. Place carefully the drilling template on the deck, by ensuring the **correct alignment** with the bow.
2. Mark and drill as indicated in the gure. Let the edges of the holes sharp, while the edge side of the holes of the chain towards the bow must be smoothed for an angle of 45° degree.
3. Place carefully the upper part of the anchor windlass on the deck.
4. Carefully place the chain stripper pipe so that the chain stripper is aligned and away 4-5 mm from the gipsy throat.
5. Connect the wires from the battery to the electrical engine by passing them out through the openings in the gearbox body.

Note:

It is recommended to seal the base of the anchor windlass to the deck by means of silicone glue.

UK

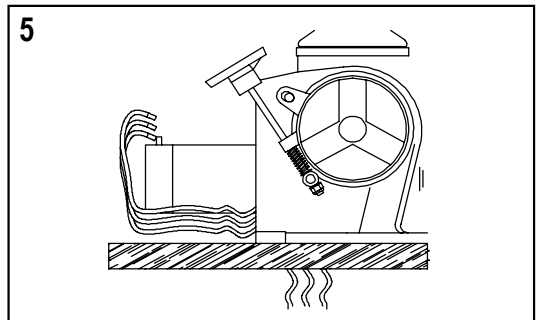
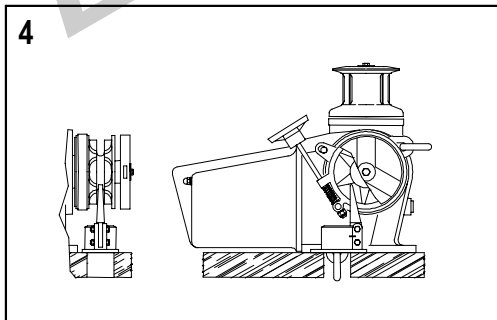
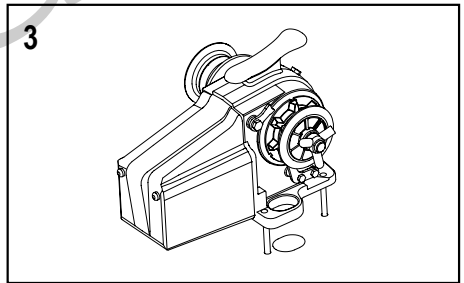
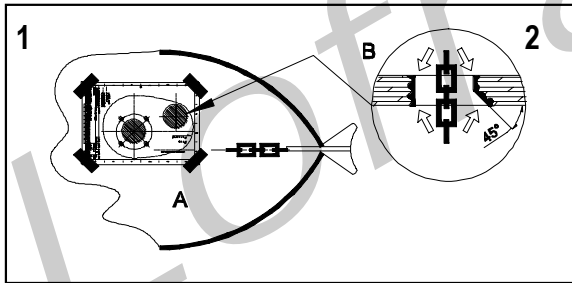

4 ELECTRICAL SYSTEM

Model	Motor Power (W)	Voltage (V)	Contactor (A)	Cable sizing according length of cable (positive + negative)			
				15-25 m	50-75 ft	> 25 m	> 75 ft
Atlas/Cayman 88 /Lion 1000	600/700/700	12	70	25 mm ²	3 AWG	-	-
Cayman 88	700	24	35	16 mm ²	4 AWG	-	-
Cayman 88	1000	12	100	35 mm ²	2 AWG	50 mm ²	2 AWG
Cayman 88	1000	24	70	25 mm ²	3 AWG	35 mm ²	3 AWG
Cayman 88	1300	48	35	6 mm ²	10 AWG	10 mm ²	8 AWG
Tigres	1500	12	100	50 mm ²	2 AWG	75 mm ²	000 AWG
Tigres	1500	24	70	35 mm ²	3 AWG	50 mm ²	2 AWG
Tigres	1500	48	35	16 mm ²	4 AWG	25 mm ²	3 AWG
Falcon	1700	12	125	50 mm ²	2 AWG	75 mm ²	000 AWG
Falcon	1700	24	70	35 mm ²	3 AWG	50 mm ²	2 AWG
Falcon	2000	24	100	50 mm ²	2 AWG	75 mm ²	000 AWG
Falcon	2200	48	70	10 mm ²	8 AWG	16 mm ²	6 AWG

4.1 Electrical cable section

It is essential that the anchor windlass be wired with cables of sufficient section as suggested in the table.

4.2 Contractor (Control Box)

Place it in a dry place near the capstan.

4.3 Circuit breakers

The circuit breakers recommended by Lofrans have an intervention curve and not a simple plate value. The switches selected for each model guarantee the correct operation of the system.

4.4 Remote control electric panel board

The remote control electric panel board must be mounted in a comfortable position (such as the deck, the rudder or the cockpit), so that the operator can see the capstan during the manoeuvre. Mount and seal the electric panel board so that the terminals remain in a dry place.

4.5 Protection of electrical components

The installer is responsible to properly protect the motor and the electrical components (such as the control box) from direct water contact. Water damage to the electrical components due to water ingress will void the warranty. Also the installer is responsible to ground the windlass unit.

4.6 Wiring diagram

FALKON 2000W WIRING DIAGRAM

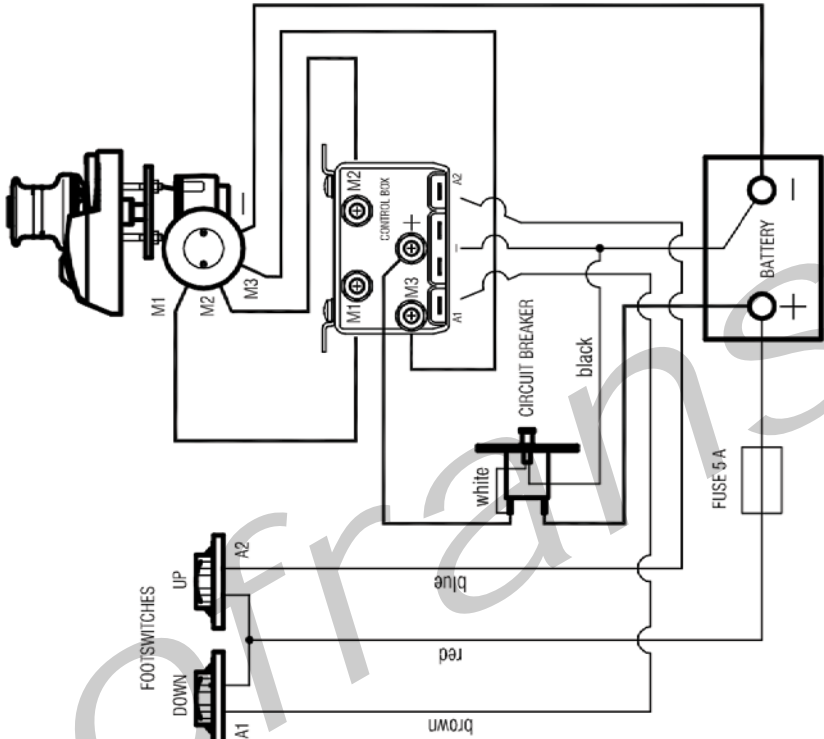

FOOTSWITCHES

DOWN UP

A2 A1

red blue

brown

ROCKER SWITCH TYPE C

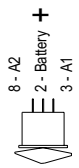

HAND HELD REMOTE CONTROL THETIS 1002

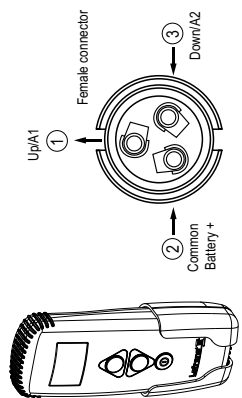

UK

LION 1000 WIRING DIAGRAM - 2 TERMINALS ELECTRIC MOTOR

WIRING DIAGRAM - 2 TERMINALS ELECTRIC MOTOR

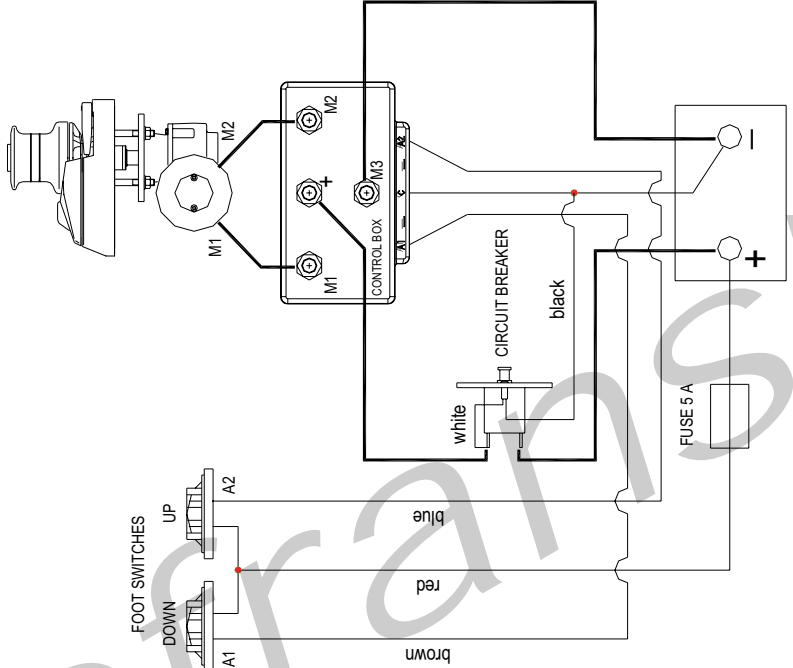

WIRING DIAGRAM CODE : E0016-A

ROCKER SWITCH TYPE C

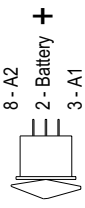

HAND HELD REMOTE CONTROL THETIS 1002

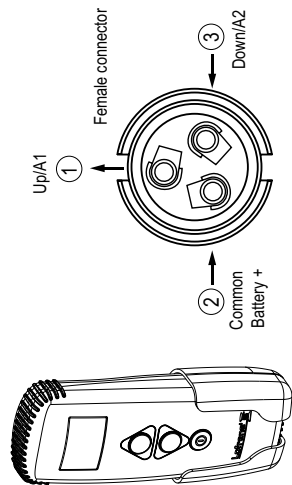

TIGRES 48V WIRING DIAGRAM - 3 TERMINALS ELECTRIC MOTOR



HAND HELD REMOTE
CONTROL THETIS 1002

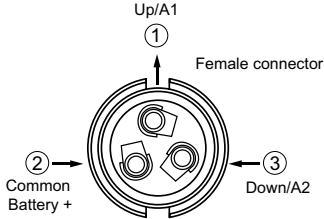
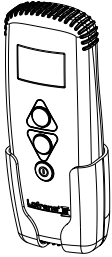

ROCKER SWITCH TYPE C

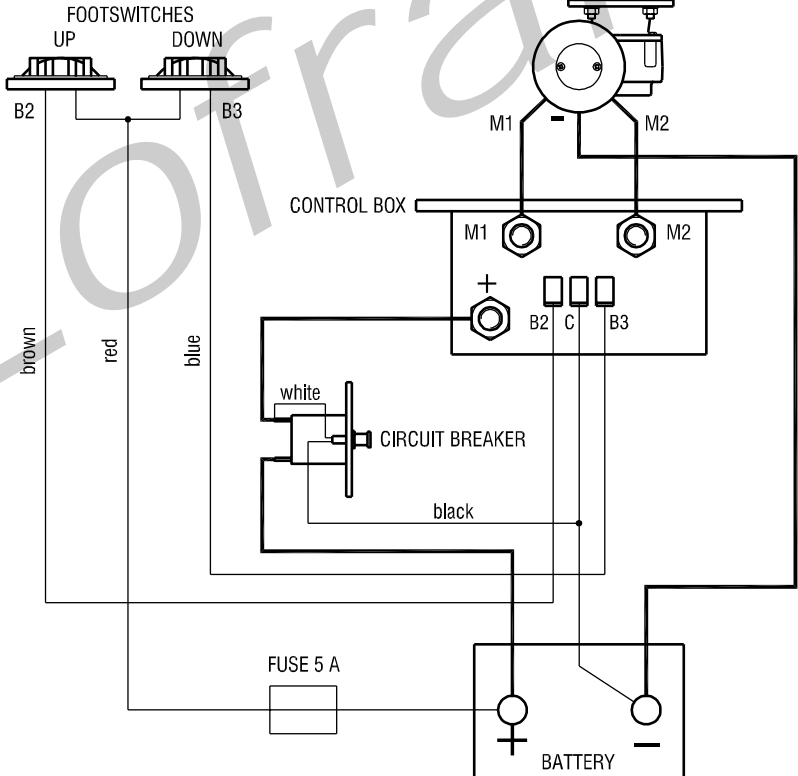
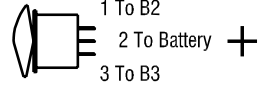

UK

CAYMAN 48V WIRING DIAGRAM - 3 TERMINALS ELECTRIC MOTOR



WIRING DIAGRAM - 3 TERMINALS ELECTRIC MOTOR

HAND HELD REMOTE
CONTROL THETIS 1002

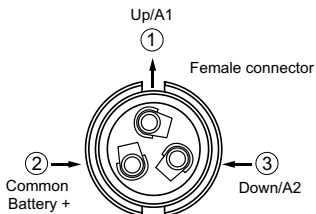
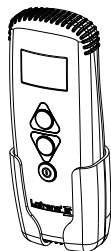

ROCKER SWITCH TYPE C

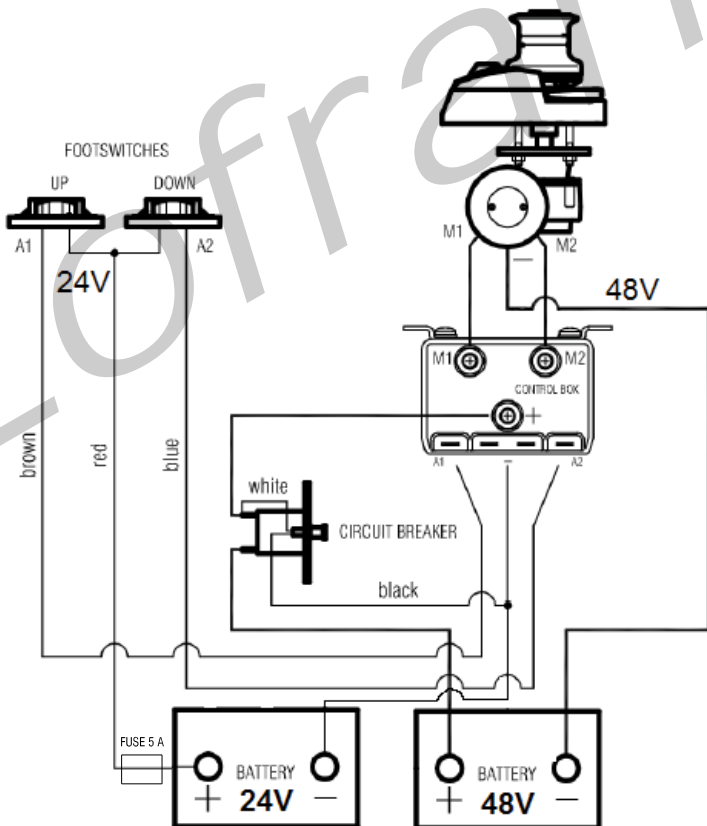
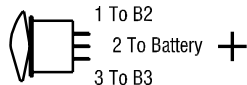

5 USE OF THE WINDLASS

 During the use of the anchor windlass, do not change directly from one direction to the other but wait until the anchor windlass stops before manipulating the control into the opposite direction

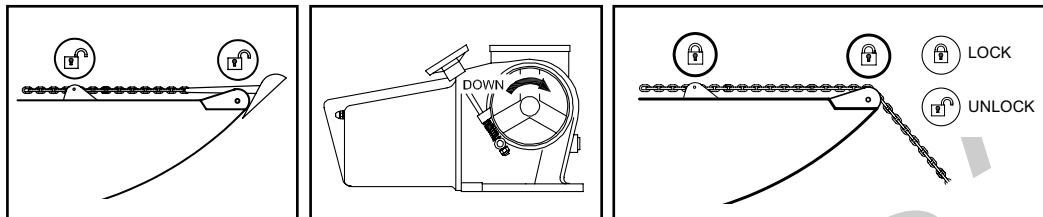

5.1 Lowering the anchor

Lowering of the anchor can be carried out through the electric control or by gravity:

5.1.1 Lowering the anchor electrically

1. Make sure that the clutch is tightened and the brake is disengaged. Disengage all chain fixing devices.
2. Activate the safety switch
3. Press the DOWN button from the control at your disposal. In this way, the lowering of the chain will be perfectly controllable and the unwinding of the chain regular.
4. Once the chain is lowered, deactivate the safety switch.
5. Engage the chain fixing devices.

UK

 Make sure the anchor windlass is not powered before carrying out manual interventions.

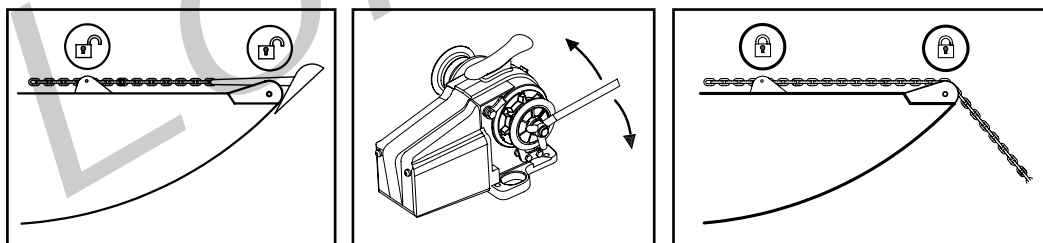

5.1.2 Lowering the anchor by gravity

1. Make sure that the clutch is tightened and then disengage the chain stopper or safety stops. Disengage the brake.
2. Disengage the clutch gradually through the manoeuvre handle.

Note: to adjust the descent speed of the chain act, through the handle, on the clutch. By turning it clockwise, the braking speed of the chain will increase (until complete stop), while by turning it anticlockwise, braking will be reduced.

3. Fix the chain (or the rope) to a strong point.

 By disengaging completely the clutch, the anchor will be lowered at high speed. Consequently, the fast passage of the chain into the hood and bow roller could damage them. It is recommended always to check the speed.

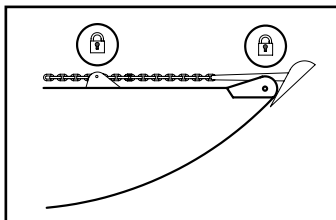
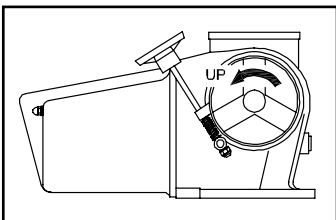
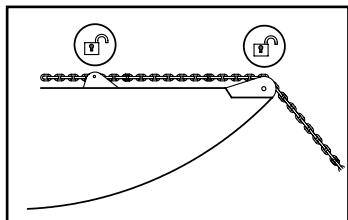

5.2 Weighing the anchor

1. Make sure that the hydraulic magnetic circuit breaker is activated.
2. Make sure that the clutch is well tightened and the brake is disengaged. Take out the manoeuvre handle from the drum or gipsy.
3. Disengage the chain stopper and safety stops.
4. Press the UP button from the control at your disposal until the anchor reaches its position inside the bow roller.
5. Deactivate the hydraulic magnetic circuit breaker.
6. Fix the chain with the chain stopper. In this way a potential damage of the anchor windlass will be avoided as well as unexpected chain releases.

 If possible, do not carry out the anchor recovery operation by relying only on the onboard batteries. Start the motor of the boat (or the generator) to obtain the necessary electromotive force.

To safeguard the anchor windlass, the hydraulic magnetic circuit breaker is sized so that it comes into action when the anchor windlass is subjected to higher loads than those for which it has been designed. Should it get released owing to an overload reactivate it again and wait some minutes before operating it; waiting for the operation after an overload is necessary to allow the circuits to cool and recover their functionalities.

 The hydraulic magnetic circuit breaker does not protect against an excessive increase in the motor temperature due to a prolonged operation of the anchor windlass. Therefore, give the motor the necessary time to cool, to avoid possible damages to the motor thereof.

5.3 Use of the manual override

Make sure that the clutch is engaged. Disengage the brake, chain stopper, and safety stops. Insert the manoeuvre handle into the handwheel and turn clockwise by overcoming the strength of the spring contained in the reducer. In case of deep sea, the effort will turn out to be significant.

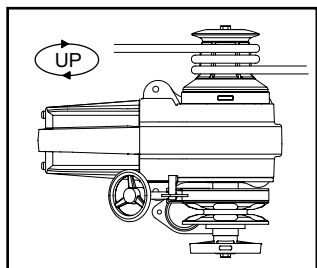
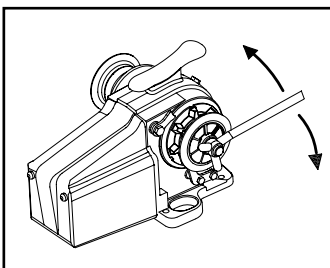
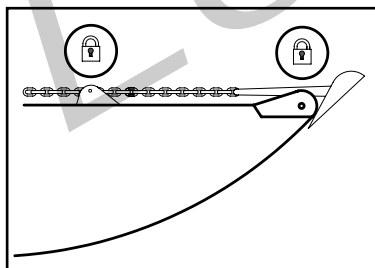

5.4 Use of the warping drum

The warping drum can be used regardless of the gipsy, to help themooing manoeuvres.

1. Tighten the brake and make sure that the anchor is appropriately blocked.
2. Disengage the clutch. This operation will make the drum independent of the gipsy.
3. Turn **clockwise** around the drum with three laps of rope.
4. By keeping the end of the rope, press the UP button and carry out the mooring manoeuvre.
5. Once the manoeuvre is ended, remove the rope from the drum and fasten it to a bollard.
6. Deactivate the safety switch.

 Always remove the manoeuvre handle when not in use.

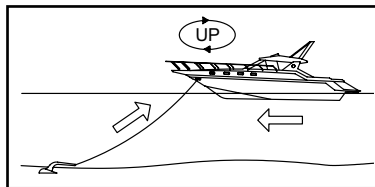
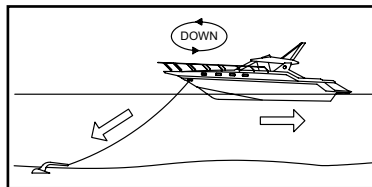
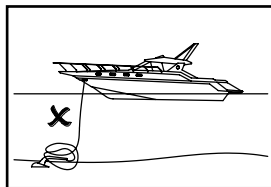

5.5 Notes for use

During mooring, the load on the chain can be very high due to current, wind and waves.

 Mooring, do not use the anchor windlass as strong point but always use a chain stopper.

 If during recovery, the anchor windlass should block, slip or turn into self-protection mode, check the cause before proceeding.

1. By paying out the chain, it is necessary to manoeuvre so that the chain is laid down on the seabed without heaping on itself.
2. To ease the recovery and not overloading the capstan, steer up in a way that the boat slowly moves on the vertical of the anchor.
3. When the anchor is in the vicinity of the bow roller, slow down the recovery to check at best the insertion of the anchor into the seat.

UK

6 MAINTENANCE

	USE OF THE YACHT (MONTHS)			
	LESS THAN 2	FROM 2 UP TO 6	MORE THAN 6	CHARTER
EVERY 3 MONTHS			A - B	A - B
EVERY 6 MONTHS		A - B		
EVERY 12 MONTHS	A - B - C	C	C	C - D
EVERY 24 MONTHS		D	D	E
EVERY 36 MONTHS	D - E	E	E	F

 Follow strictly the maintenance programme. Not meeting the maintenance programme will cause forfeiture of the warranty.

 Disconnect power to the anchor windlass before any maintenance.

6.1 Maintenance programme

For obtaining the best performances and the utmost efficiency of the anchor windlass, it is necessary to follow strictly the maintenance programme indicated hereby.

- A. Clean all external surfaces and hidden points with fresh water and remove all salt layers. Use soap water only (no chlorine solutions).
- B. Grease the rotating parts. Particularly, the main shaft threads and clutch cones. Check for evidences of corrosion and mechanical stresses. In case of galvanic corrosion check if windlass is subjected to "stray" currents.
- C. Check the terminals of the electric motor. Test the voltage drop at the terminals. Control box must be in a dry area.
- D. Replace all gaskets and oil.
- E. Remove the anchor windlass from the deck to clean the salt under the base and seal again. Check for corrosion.
- F. Remove inox screws that mount the windlass on the deck and the Stripper on the windlass, apply a chromate free joining compound designed to inhibit electrolytic decomposition.

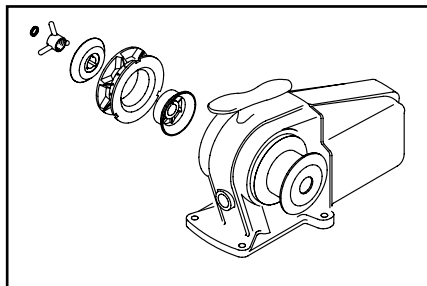
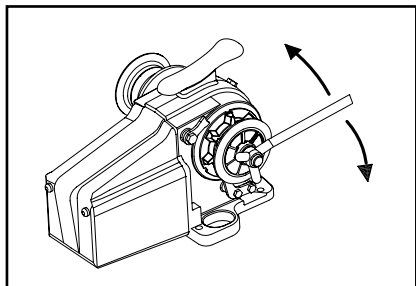

6.2 Gipsy maintenance/replacement

1. By turning anticlockwise, remove the gipsy through the manoeuvre handle.
2. Slip off from the shaft the upper clutch cone, the gipsy, and the lower clutch cone.
3. Wash with running water. DO NOT USE WATER UNDER PRESSURE.
4. Check that there is no evidence of corrosion or mechanical stresses.
5. Reassembly by proceeding in the reverse order, remembering to lubricate threads and all moving parts with grease.

For Tigres 48V with rope kit consult the manual link: www.lofrans.com/product/79-kits/4879-rope-kit-for-tigres-8-iso-5-16-ht

7 TROUBLESHOOTING

Problem	Possible causes	Solution
1. The anchor windlass does not work when a control is operated	<ol style="list-style-type: none"> 1.1 Protection switch in OFF position 1.2 Lack of voltage in the system 1.3 Failure of the control box 1.4 Failure of the control 1.5 Failure of the electric motor 	<ol style="list-style-type: none"> 1.1 Check the protection switch and set it in the ON position 1.2 Check the charge status of the battery, check connections 1.3 Check and possibly replace the control box 1.4 Check and possibly replace the control 1.5 Measure the electric motor voltage; if it is OK, check the brushes and clean them. If it does not work, replace the electric motor
2. The chain jams frequently	<ol style="list-style-type: none"> 2.1 The chain locker is not deep enough with respect to the quantity of chain chosen 2.2 The chain is not suitable for the gipsy 2.3 The chain is not calibrated 	<ol style="list-style-type: none"> 2.1 Position the anchor windlass in the deepest point of the chain locker or reduce the quantity of chain 2.2 Change the gipsy 2.3 Check the chain: if it does not meet the tolerances, it must be replaced
3. The anchor windlass turns slowly	<ol style="list-style-type: none"> 3.1 Unsuitable cable sections 3.2 Deck floors not parallel 3.3 Bad electrical connections 3.4 Dirty brushes 3.5 Water infiltrations in the electric motor 	<ol style="list-style-type: none"> 3.1 Increase cable section 3.2 Make floors parallel by interposing thicknesses 3.3 Check connections 3.4 Clean brushes 3.5 Replace the electric motor

Problem	Possible causes	Solution
<p>4. The electric engine runs but the shaft does not rotate either Up or Down</p>	<p>4.1 Heavy wear or breakage of teeth of the crown / worm screw. 4.2 Breakage of the engine spindle.</p>	<p>4.1 (SERVICE) Uninstall the winch and replace the broken parts. Check out carefully that pieces or splinters of broken parts did not enter into the oil circuit and have ruined other mechanical parts. (*) 4.2 (SERVICE) Replacing of the engine. Care must be taken that the broken part did not remain in the hole of the worm screw. (*) (*) Take advantage of this opportunity to replace any other worn parts, especially gaskets, screws, tabs, seeger, and oil.</p>
<p>5. The electric engine runs, the shaft rotates Up, but does not rotate Down</p>	<p>5.1 The chain locker is tangled; therefore, the emergency mechanism becomes operative. 5.2 The chain is of poor quality with burrs and zinc deposits that do not allow the free flow of the links; therefore, the emergency mechanism becomes operative. 5.3 The chain was placed in the locker in block and the links are stuck with each other; therefore, the emergency mechanism becomes operative. 5.4 Wear of the emergency mechanism of the spring control. 5.5 The chain stripper interferes with the gypsy: it is possible to weigh the operation, while to lower, the emergency mechanism becomes operative.</p>	<p>5.1 Check out that immediately after the anchor there is a joint that allows the chain to unfold properly when weighed. 5.2 Remove the chain from the locker and inspect it link by link. Intervene with the appropriate tools to make it as loose as possible and free of obstructions. 5.3 Lower manually all the chain in a sea bed deep enough to enable it to unfold properly. Retrieve it with the winch. 5.4 A (SERVICE) Uninstall the winch from the boat and disassemble it into its parts by replacing the spring. Take advantage of this opportunity to replace any other worn parts, gaskets, screws, tabs, seeger, and oil. B (SERVICE) It is possible to block the EMERGENCY MECHANISM so that the gears are always engaged both in UP and in Down. This operation must be authorized by the shipowner. The solution rules out completely the possibility of carrying out the emergency operation. 5.5 Restore the condition of the chain stripper by repositioning properly in the gypsy centreline. If it is deformed. It must be replaced.</p>
<p>6. The electric engine runs but it cannot be bell warped.</p>	<p>6.1 The bell warp is being used wrongly; therefore, the emergency mechanism becomes operative</p>	<p>6.1 To carry out the warping operation the main shaft must run in the same rotation direction of the winch gypsy when it weighs the chain.</p>
<p>7. The winch cannot be weighed: the electric engine runs, the shaft runs, but the gypsy is still although the brake belt is loose.</p>	<p>7.1 The gypsy is not closed on the clutch cones and slips under the load effect, or for some reason the closing wheel is at end stroke. Check out all pieces in sequence. 7.2 The clutch cones or the gypsy cones are deformed and the clutch hubs are in contact and prevent closure.</p>	<p>7.1 Check out clutch tightening. If necessary, measure the parts and check out possible deformations. It is possible to add some thickness to stem the problem. Then replace the damaged parts. 7.2 Replace the clutch and/or the gypsy</p>
<p>8. The shaft does not run well, is not aligned, and so is the gypsy and/or the bell.</p>	<p>8.1 The shaft bent because the winch was subjected to an excessive load.</p>	<p>8.1 Check out that the procedures of use fall within the specifications of the winch. (SERVICE) Uninstall the winch and replace the shaft. Take this opportunity to replace worn parts, gaskets, seeger, tabs and oil.</p>

UK

Problem	Possible causes	Solution
<p>9. Loss of oil between the engine and the gearbox body</p>	<p>9.1 The coupling of the engine is loose and causes the worm screw into an irregular rotation, leading to loss of oil from the gasket.</p>	<p>9.1 (SERVICE) Find the reasons why the screws or nuts have become loose. Uninstall the engine and check out the status of the spindle and the hole of the worm screw. If an oval form of the cylindrical part of the screw is observed (outer hole and diameter) uninstall the winch and repair the damaged parts on the bench. Check out if the oil has entered into the electrical engine. Take this opportunity to replace all gaskets, tabs, seeger, screws, oil, and any worn parts.</p>
<p>10. On installation, it is found that the shaft and the studs are short for a correct coupling with the gearbox.</p>	<p>10.1 The request referred to the deck thickness was wrong.</p>	<p>10.1 If the key shaft works in the gearbox along all its length, the fixing studs can be adapted. Otherwise, a longer shaft must be requested.</p>
<p>11. The winch runs slowly and at times jumps the circuit breaker.</p>	<p>11.1 Section of cables not suitable. 11.2 Poor electrical connections. 11.3 Dirty brushes. 11.4 Water leaks in the electrical engine. 11.5 There is no parallelism between upper deck and below deck. 11.6 The gearbox has lost oil. 11.7 The engine strains in one or both directions. 11.8 The winch works only in one direction.</p>	<p>11.1 Increase the cable section 11.2 Check out the connections 11.3 Clean the brushes 11.4 Replace the electrical engine 11.5 Work surfaces and/or add shims to restore parallelism. 11.6 (SERVICE) Uninstall the gearbox and check out its condition. Replace damaged parts after discovering the causes of the leak. Also, replace gaskets and screws. Check out also the engine condition, which may have been damaged during the malfunction. 11.7 (SERVICE) Check out appropriately all connections of the power cables. If they are alright, uninstall the engine (in some cases it is convenient to disassemble also the gearbox). Check out and possibly replace the brushes. 11.8 Check out on the control box that between B2-C and B3-C contacts there are 12/24V when the respective buttons are pressed. If this should happen and one of the relays does not work, replace the control box.</p>
<p>12. The finger is broken</p>	<p>12.1 Poor layout of the cable top or rolling of the chain has broken the finger. Check out the suitability of the gypsy to work with the finger.</p>	<p>12.1 Replace the finger. 12.2 In the event that the gypsy cannot work properly with the finger, position the replacement kit (cap).</p>

8 TECHNICAL DATA

Model	LION 1000		CAYMAN 88			
	700 W	700W	1000W	1300W		
Motor Power	700 W	700W	1000W	1300W		
Vessel Length Heavy Duty (ft)	25-35	25-35	35-45	40-50		
Vessel Length Light Duty (ft)	35-40	35-45	40-50	45-55		
Power Supply	12V	12V	24V	12V	24V	48V
Maximum linear Load/Pull (Kg/lb)	575 / 1268	1050 / 2310	1050 / 2310	1300 / 2860	1300 / 2860	1340/2955
Max Lift Working Load (Kg/lb)	105 / 232	135 / 297	135 / 297	165 / 363	165 / 363	170/375
Amps Work Load (A)	60	110	110	117	117	31
Max Line Speed (mt./min.) / (ft/min.)	26 / 85	30 / 90	30 / 90	35 / 105	35 / 105	22 / 72
Line Speed (mt./min.) / (ft/min.)	23 / 75	25 / 75	25 / 75	25 / 75	25 / 75	16 / 52
Net weight with Drum (Kg/lb)	N/A	24 / 53	24 / 53	25 / 55	25 / 55	25 / 55
Net weight Low Profile (Kg/lb)	11 / 25	N/A	N/A	N/A	N/A	N/A

LION 1000

Chain supported for gipsy	6mm		8mm	
	ISO	DIN 766	ISO	DIN 766
Rope supported for drum	10-12mm – 3/8-1/2"		12mm - 1/2"	

CAYMAN 88

Chain supported for gipsy	6mm		8mm		5/16"		10mm	3/8"	10mm	3/8"
	ISO	DIN 766	ISO	DIN 766	G4	BBB	ISO	G4	DIN 766	BBB
Rope supported for drum	N/A		14mm-16mm-9/16"-5/8"				N/A		N/A	



Model	TIGRES			FALKON			
	1500W			1700W	2000W	2200W	
Vessel Lenght Heavy Duty (ft)	40-50			45-55		50-60	
Vessel Lenght Light Duty (ft)	50-55			55-60		60-65	
Power Supply	12V	24V	48V	12V	24V	24V	48V
Maximum linear Load/ Pull (Kg/lb)	1500 / 3300	1590 / 3900	1000 / 2200	1700 / 3740	1700 / 3740	2640 / 5820	2880 / 6350
Max Lift Working Load (Kg/lb)	190 / 418	200 / 440	120/264	215 / 473	225 / 496	330 / 727	360 / 794
Amps Work Load (A)	160	90	33	210	100	110	61
Max Line Speed (mt./min.) / (ft/min.)	33 / 99	33 / 99	20/60	32 / 96	32 / 96	33 / 99	21 / 69
Line Speed (mt./min.) / (ft/min.)	14 / 41	16 / 48	20/60	16 / 48	16 / 48	19 / 57	12 / 39
Net weight with Drum (Kg/lb)	28 / 62	28 / 62	28/62	55 / 121	55 / 121	57 / 125	57 / 125

TIGRES 12/24V

Chain supported for gipsy	8mm		5/16"		10mm	3/8"	10mm	3/8"
	ISO	DIN 766	G4	BBB	ISO	G4	DIN 766	BBB
Rope supported for drum	14mm-16mm-9/16"-5/8"				16mm-5/8"		16mm-5/8"	

FALKON

Chain supported for gipsy	10mm	3/8"	10mm	3/8"	12mm	13mm	7/16"
	ISO	G4	DIN 766	BBB	ISO	DIN 766	G4
Rope supported for drum	16mm-5/8"		16mm-5/8"		18mm-3/4"		

TIGRES 48V WITH ROPE KIT

Chain support for gipsy	8mm ISO - 5/16 HT	10mm ISO - 3/8 HT
Rope support for gipsy	14mm 3strad 8 plaite	16mm 3strad 8 plaite
Rope support for drum	14mm - 16mm 9/16" - 5/8"	16mm-5/8"

9 SPARE PARTS

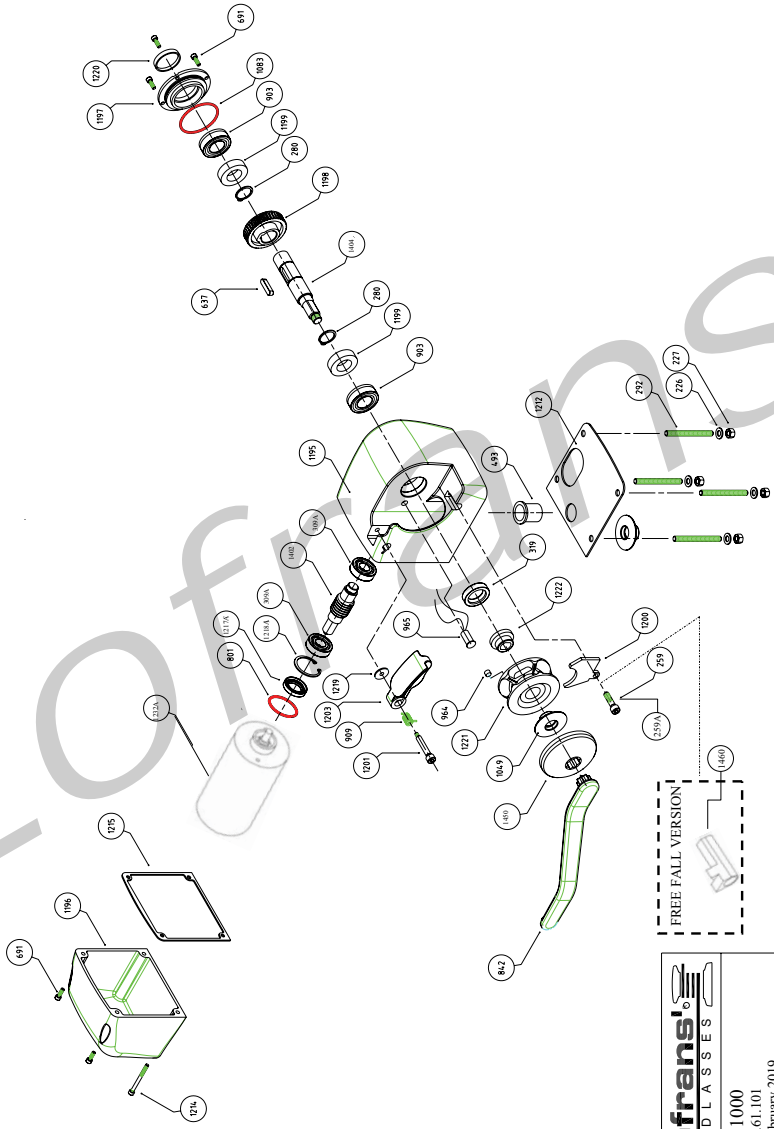

UK

FREE FALL VERSION

Lofrans! WINDLASSES
LION 1000
Code: B.G.I.101
Date: February 2019

LION 1000

Item	Description	Kit	Q.ty
1221a	Gipsy chain 6 - 6 pockets		1
1221c	Gipsy chain 8 - 5 pockets		1
1221b	Gipsy chain 7 - 6 pockets		1
226	Washer for M8 screw	Kit B	4
227	Nut - M8	Kit B	4
259A	Hd cap screw - M8x42 (Freefall version)	Kit B	1
259	Hd cap screw - M8x16	Kit B	1
280	Circlip 25 Din 471	Kit D	2
292a	Stud M8x75		4
309A	Bearing		2
319	Seal 25x42x7	Kit A	1
493	Bush		1
637	Key 8x7x30	Kit C	1
639	Washer	Kit B	1
801	O Ring - 150	Kit A	1
842a	Handle		1
903	Bearing		2
909	Spring		1
964	Magnet		1
965	Sensor		1
1049	Cone Clutch - out		1
1222	Cone Clutch - in		1
1450	Gipsy Cap		1
1083	O Ring - 3250	Kit A	1
1195	Body		1
1196	Motor Cover		1
1197	Cover		1
1198	Wormwheel		1
1199	Spacer		2
1200	Stripper		1
1201	Screw		1
1202	Worm		1
1203	Finger		1
1204	Main shaft		1
1212	Gasket		1
1214	Hd cap screw - M5x80	Kit B	2
1215	Gasket		1
1232A	Electric Motor 700W		1
1217A	Seal 20x37x7	Kit A	1
1218A	Circlip 37 Din 472	Kit D	1
1220	Cap	Kit A	1
1460	Freefall		1
KA53101	Kit A - Seals		1
KB53101	Kit B - Screw&Nuts		1
KC53101	Kit C - Keys		1
KD53101	Kit D - Circlips		1

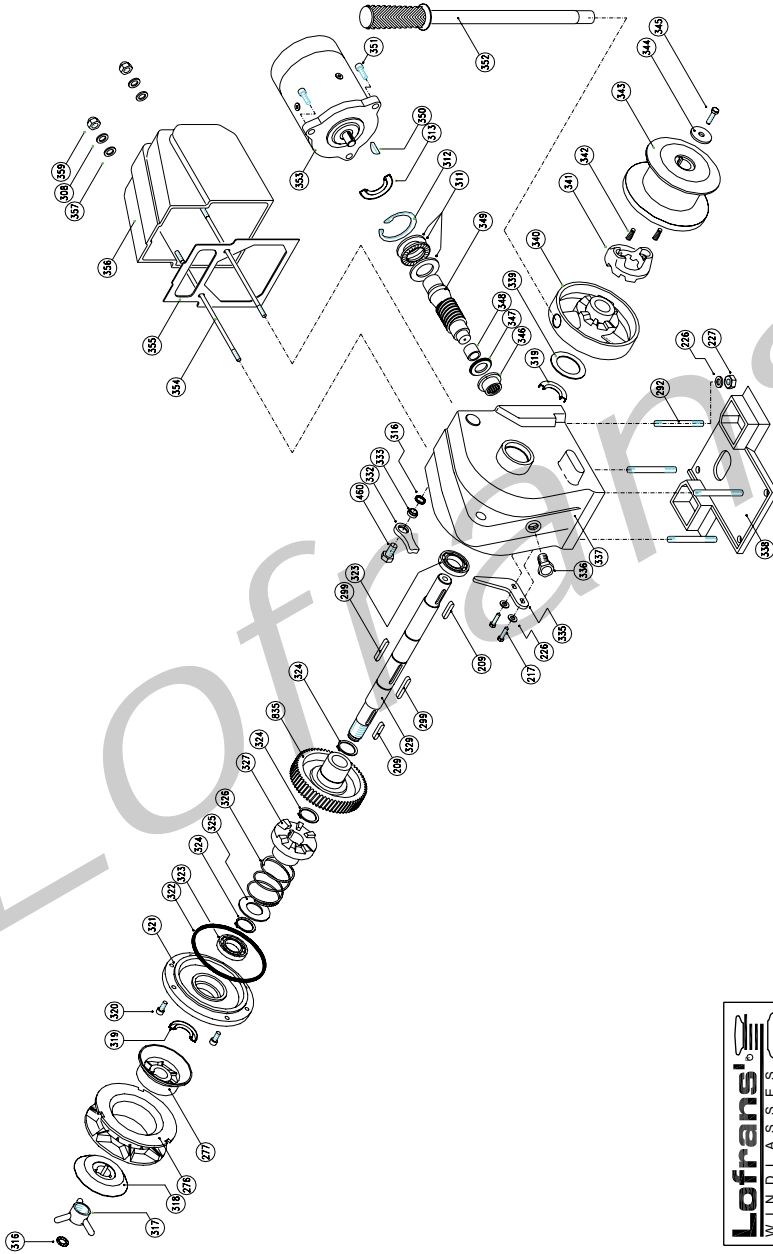

UK

Lofrans! WINDLASSES
CAYMAN 88
code: B.09.101
date: January 2001

CAYMAN 88

Item	Description	Kit	Q.ty
209	Key - 6x6x30	Kit C	4
217	Hex hd screw M8x20	Kit B	2
226	Washer for screw M8	Kit B	6
227	Nut - M8	Kit B	4
276a	Gipsy chain 6 Iso - Din 766		1
276b	Gipsy chain 7 Iso - 1/4" G40		1
276c	Gipsy chain 8 Iso - Din 766 - 5/16" BBB		1
276d	Gipsy chain 5/16 G40		1
276e	Gipsy chain 10 Iso - 3/8 G40		1
276f	Gipsy chain 3/8 Din 766 - 10 Din 766		1
276g	Gipsy chain 3/8 BBB		1
276h	Gipsy chain 3/8 PC		1
277	Clutch cone - inner		1
292a	Stud - M8x76		4
308	Washer for screw M6	Kit B	2
311	Thrust bearing - 511105		1
312	Circlip - 43 Din 472	Kit D	1
313	Seal - 25x43x9	Kit A	1
316	O Ring seal - 117	Kit A	2
317	Wingnut		1
318a	Clutch cone - outer		1
318b	Clutch cone- outer (for gipsy type e-f-g-h)		1
319	Seal - 25x42x6	Kit A	2
320	Hd cap screw - M6x16	Kit B	4
321	Cover		1
322	O Ring seal - 4437	Kit A	1
323	Bearing - 6005		2
324	Circlip - 25 Din 471	Kit D	3
325	Washer		1
326	Spring		1
327	Dog clutch		1
329	Main shaft		1
332	Pawl		1
333	Spacer		1
335	Stripper for gipsy type a - b - c - d		1
335a	Stripper for gipsy type e - f - g - h		1
336	Oil plug 3/8		1
337	Body		1
338	Gasket		1
339	Nylon washer		1
340	Emergency wheel		1
341	Emergency dog clutch		1
342	Spring		2
343	Drum		1
344	Washer		1

Item	Description	Kit	Q.ty
345	Hex hd screw M6x20	Kit B	1
346	Combined bearing - Rax 720		1
347	Thrust ring - CP 32035		1
348	Ring - IM 1520164		1
349	Worm		1
350	Round key - 4x6,5	Kit C	1
351	Hd cap screw - M6x20	Kit B	3
352	Handle		1
353a	Electric motor 700W 12V		1
353b	Electric motor 700W 24V		1
353c	Electric motor 1000W 12V		1
353d	Electric motor 1000W 24V		1
353e	Electric Motor 1300W 48V		1
354	Stud - M6x180		2
355	Gasket		1
356a	Motor cover		1
356b	White motor cover		1
357	Nylon washer for screw M6	Kit B	2
359	Cap nut M6	Kit B	2
460	Hex hd screw M10x20	Kit B	1
835	Wormwheel		1
KA08101	Kit A - Seals		1
KB08101	Kit B - Screw&Nuts		1
KC08101	Kit C - Keys		1
KD08101	Kit D - Circlips		1

B.09.101 - Rev. A Date: 01-2005

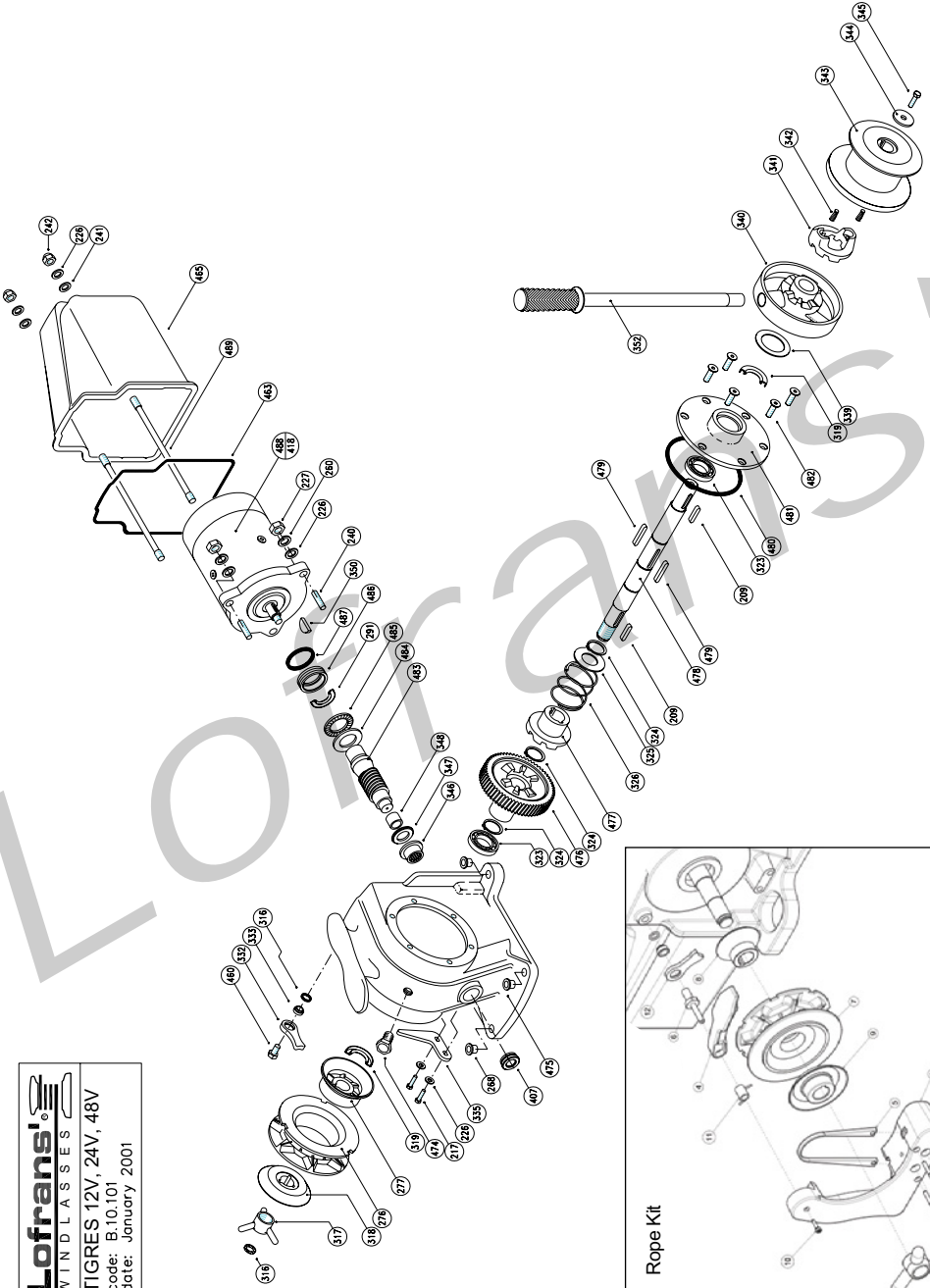

UK

Lofrans!
WINDLASSES

TIGRES 12V, 24V, 48V
code: B.10.101
date: January 2001

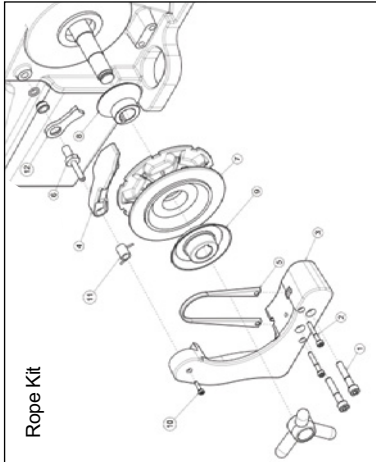

TIGRES

Item	Description	Kit	Q.ty
209	Key - 6x6x30	Kit C	2
217	Hex hd screw M8x20	Kit B	2
226	Washer for screw M8	Kit B	7
227	Nut - M8	Kit B	3
240	Stud - M8x45		3
241	Nylon washer for screw M8	Kit B	2
242a	Cap nut M8	Kit B	2
260	Spring washer M8	Kit B	3
268	Nylon bush		4
276a	Gipsy chain 6 Iso - Din 766		1
276b	Gipsy chain 7 Iso - 1/4" G40		1
276c	Gipsy chain 8 Iso - Din 766 - 5/16" BBB		1
276d	Gipsy chain 5/16 G40		1
276e	Gipsy chain 10 Iso - 3/8 G40		1
276f	Gipsy chain 3/8 Din 766 - 10 Din 766		1
276g	Gipsy chain 3/8 BBB		1
276h	Gipsy chain 3/8 PC		1
277	Clutch cone - inner		1
291	Seal - 25x35x7	Kit A	1
316	O Ring seal - 117	Kit A	2
317	Wingnut		1
318a	Clutch cone - outer		1
318b	Clutch cone- outer (for gipsy type e-f-g-h)		1
319	Seal - 25x42x6	Kit A	2
323	Bearing - 6005		2
324	Circlip - 25 Din 471	Kit D	3
325	Washer		1
326	Spring		1
332	Pawl		1
333	Spacer		1
335	Stripper for gipsy type a - b - c - d		1
335a	Stripper for gipsy type e - f - g - h		1
339	Nylon washer		1
340	Emergency wheel		1
341	Emergency dog clutch		1
342	Spring		2
343	Drum		1
344	Washer		1
345	Hex hd screw M6x20	Kit B	1
346	Combined bearing - Rax 720		1
347	Thrust ring - CP 32035		1
348	Ring - IM 1520164		1
350	Round key - 4x6,5	Kit C	1
352	Handle		1
369	Washer for screw M10	Kit B	1
407	Sightglass		1
418a	Electric motor 1500W 12V		1
418b	Electric motor 1500W 24V		1
418c	Electric motor 1500W 48V		1
460	Hex hd screw M10x20	Kit B	1
463	Gasket		1
465a	Motor cover		1
465b	White motor cover		1
474	Oil plug 1/4"		1
475	Body		1
476	Wormwheel		1
477	Dog clutch		1
478	Main shaft		1
479	Key - 6x6x40	Kit C	2
480	O Ring seal - 4462	Kit A	1

Item	Description	Kit	Q.ty
481	Cover		1
482	Conic hd screw - M6x16	Kit B	6
483	Worm		1
484	Thrust ring - CP 3 2542		1
485	Thrust bearing - AX 2542		1
486	Spacer		1
487	O Ring seal - 4143	Kit A	1
488a	Electric motor 1000W 12V		1
488b	Electric motor 1000W 24V		1
489	Stud - M8x218		2
KA10101	Kit A - Seals		1
KB10101	Kit B - Screw&Nuts		1
KC10101	Kit C - Keys		1
KD10101	Kit D - Circlips		1

B.10.101 - Rev. A Date: 01-2005

ROPE KIT

Nr.	Code	Description
1	04341	Hexagon Screw M8x45
2	634119	Hexagon Screw M6x40
3	05989	Body
4	05990	Finger
5	05991	Stripper
6	05992	Finger Pin
7	05993	Gipsy for Ø 8 or 5/16" chain
8	05994	Inner Cone Clutch
9	631842	Outer Cone Clutch
10	05159	Hexagon Screw M4x16
11	636100	Spring
12	635342	Pawl

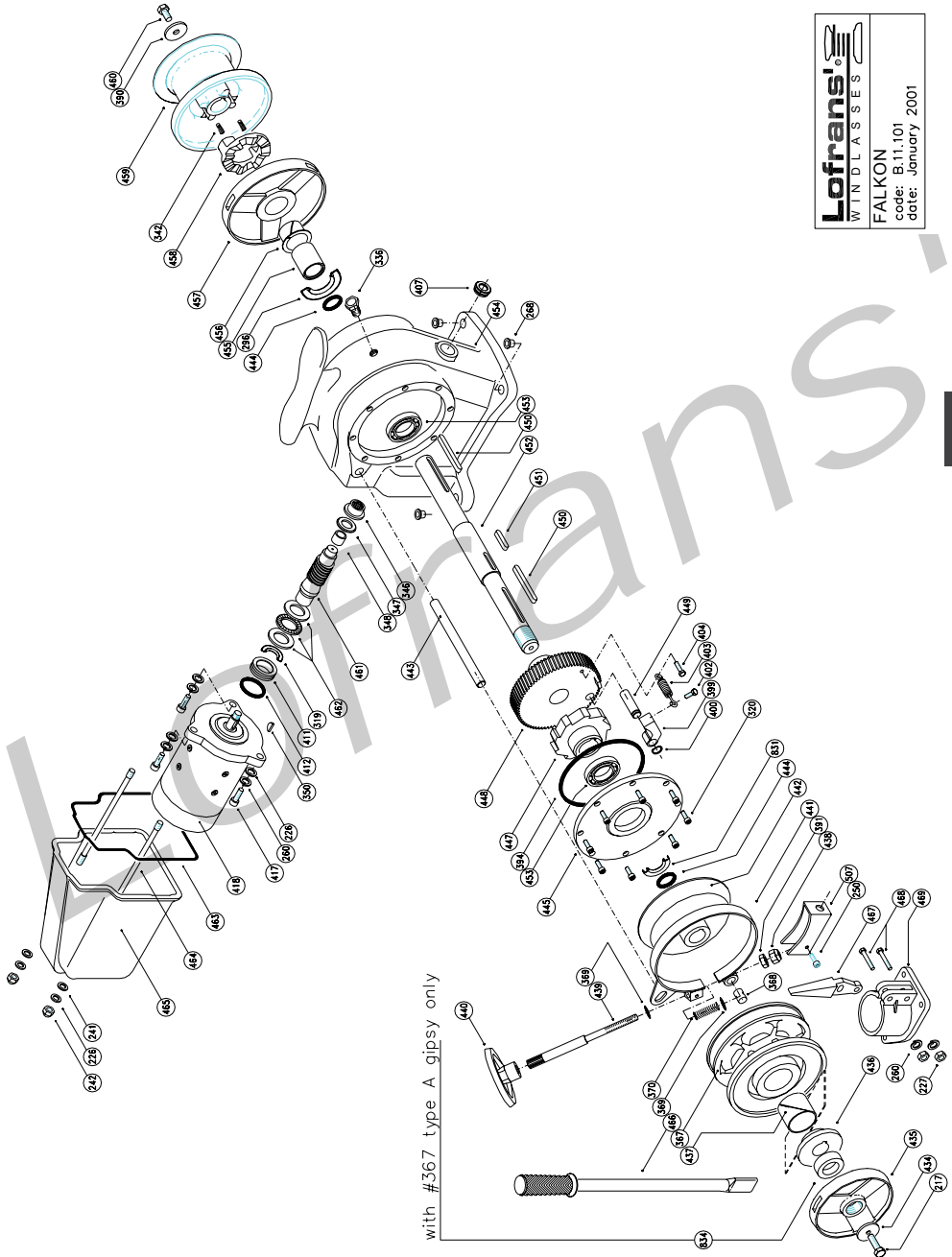

with #367 type A gipsy only

Lofrans! WINDLASSES	FALKON
	code: B.11.101
	date: January 2001

UK

FALKON

Item	Description	Kit	Q.ty
217	Hex hd screw M8x20	Kit B	1
226	Washer for screw M8	Kit B	5
227	Nut - M8	Kit B	2
241	Nylon washer M8	Kit B	2
242a	Cap nut M8	Kit B	2
250	Hd cap screw - M5x8	Kit B	1
260	Spring washer for screw M8	Kit B	5
268	Nylon bush		4
296	Seal - 40x56x8	Kit A	1
319	Seal - 25x42x6	Kit A	1
320	Hex hd screw M6x16	Kit B	8
336	Oil plug 3/8"		1
342	Spring		2
346	Combined bearing - Rax 720		1
347	Thrust ring - CP 32035		1
348	Ring IM 1520164		1
350	Round key 4x6,5	Kit C	1
364	Clutch cone - outer		1
367a	Gipsy chain 8 Iso		1
367b	Gipsy chain 10 Iso - 3/8 G40		1
367c	Gipsy chain 3/8 Din766 - BBB - 10 Din766		1
367d	Gipsy chain 12 Iso - 13 Din766 - 1/2Din766		1
367e	Gipsy chain 1/2 G40		1
367f	Gipsy chain 1/2 BBB		1
367g	Gipsy chain 14 Iso		1
367h	Gipsy chain 10 Iso		1
367i	Gipsy chain 3/8" G40		1
368	Pivot		1
369	Washer for screw M10	Kit B	2
370	Spring		1
385	Hex hd screw M10x30	Kit B	1
391	Nut - M10	Kit B	1
394	O Ring seal - 4625	Kit A	1
400	Circlip - 15 Din 471	Kit D	1
402	Hex hd screw M6x16	Kit B	1
403	Spring		1
404	Hex hd screw M6x25	Kit B	1
407	Sightglass		1
411	Spacer		1
412	O Ring seal - 153	Kit A	1
417	Hd cap screw - M8x30	Kit B	3
418a	Electric motor 1200 W 12 V		1
418b	Electric motor 1200 W 24 V		1
418c	Electric motor 1500 W 12 V		1
418d	Electric motor 1500 W 24 V		1
418i	Electric Motor 2200W 48V		1
434	Washer	Kit B	1
435	Wingnut		1
436	Clutch cone - outer		1
437a	Nylon band for chainØ8		1
437c	Nylon band for chainØ10		1
438	Safety nut M10	Kit B	1
439	Brake pivot		1
440	Hand-wheel		1
441	Band brake		1
442	Clutch cone - inner		1
443	Brake pivot		1
444	O Ring seal - 4112	Kit A	2
445	Cover		1
447	Ratchet		1
448	Wormwheel		1
449	Pivot		1

Item	Description	Kit	Q.ty
450	Key - 8x7x80	Kit C	2
451	Key - 10x8x40	Kit C	1
452	Main shaft		1
453	Bearing - 6206		2
454	Body		1
455	Spacer		1
456	Nylon bush		1
457	Emergency wheel		1
458	Dog clutch		1
461	Worm		1
462	Thrust bearing - 51106		1
463	Gasket		1
464	Stud - M8x285		2
465	Motor cover		1
466	Handle		1
467	Stripper		1
468	Hex hd screw M8x40	Kit B	2
469	Chain pipe		1
507a	Brake cover		1
831	Seal - 42x56x7	Kit A	1
839a	Chromed bronze drum-upper part		1
840	Chromed bronze drum-lower part		1
1004	Washer		1
1108	Pawl		1
KA11101	Kit A - Seals		1
KB11101	Kit B - Screw&Nuts		1
KC11101	Kit C - Keys		1
KD11101	Kit D - Circlips		1

B.11.101 - Rev. B Date: 02-2006

For Falkon 2000W 24V

Item	Description
418e	Electric motor 2000W 24V
319a	Seal - 30x42x7
461a	Worm for 2000W motor
453a	Bearing - 7206

10 OVERALL DIMENSIONS

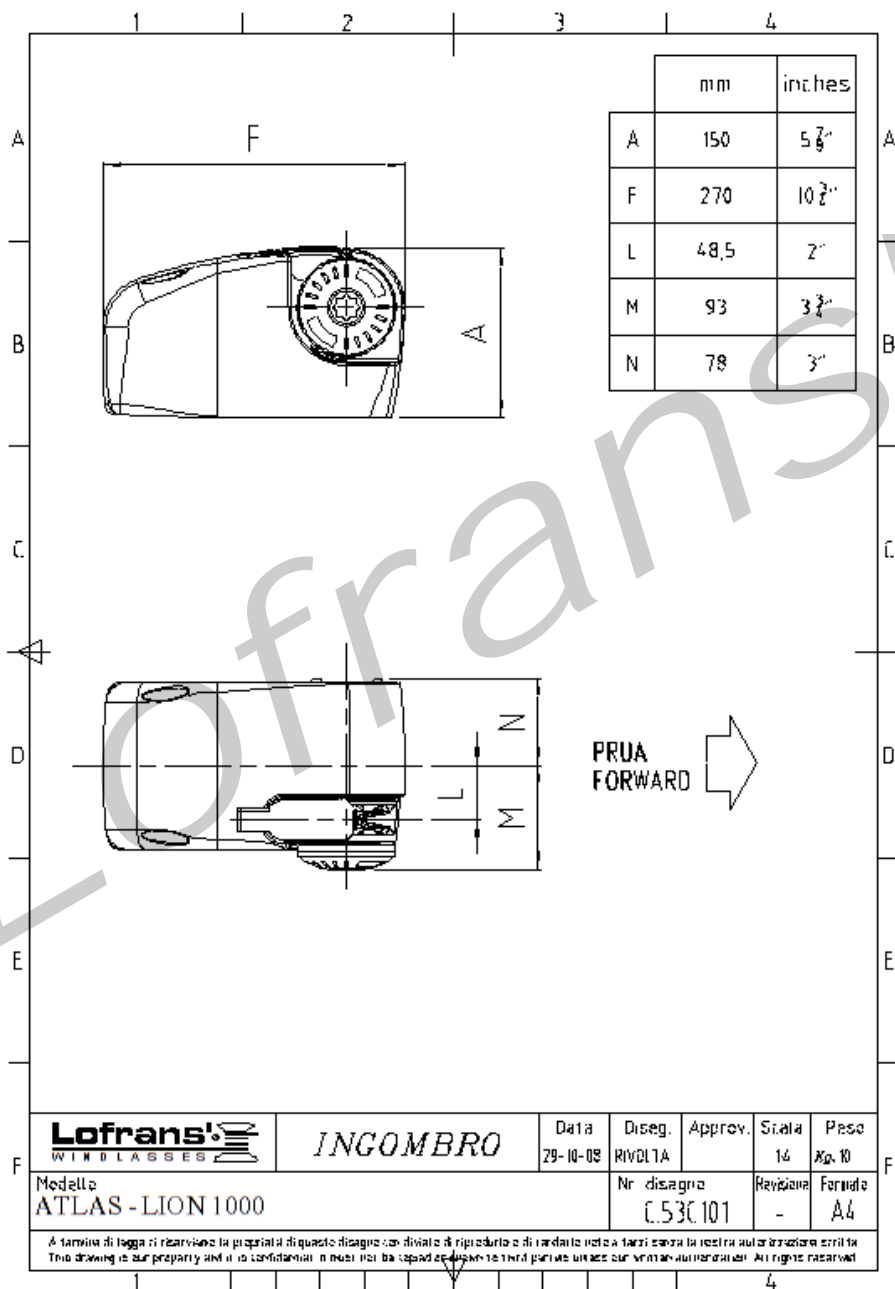

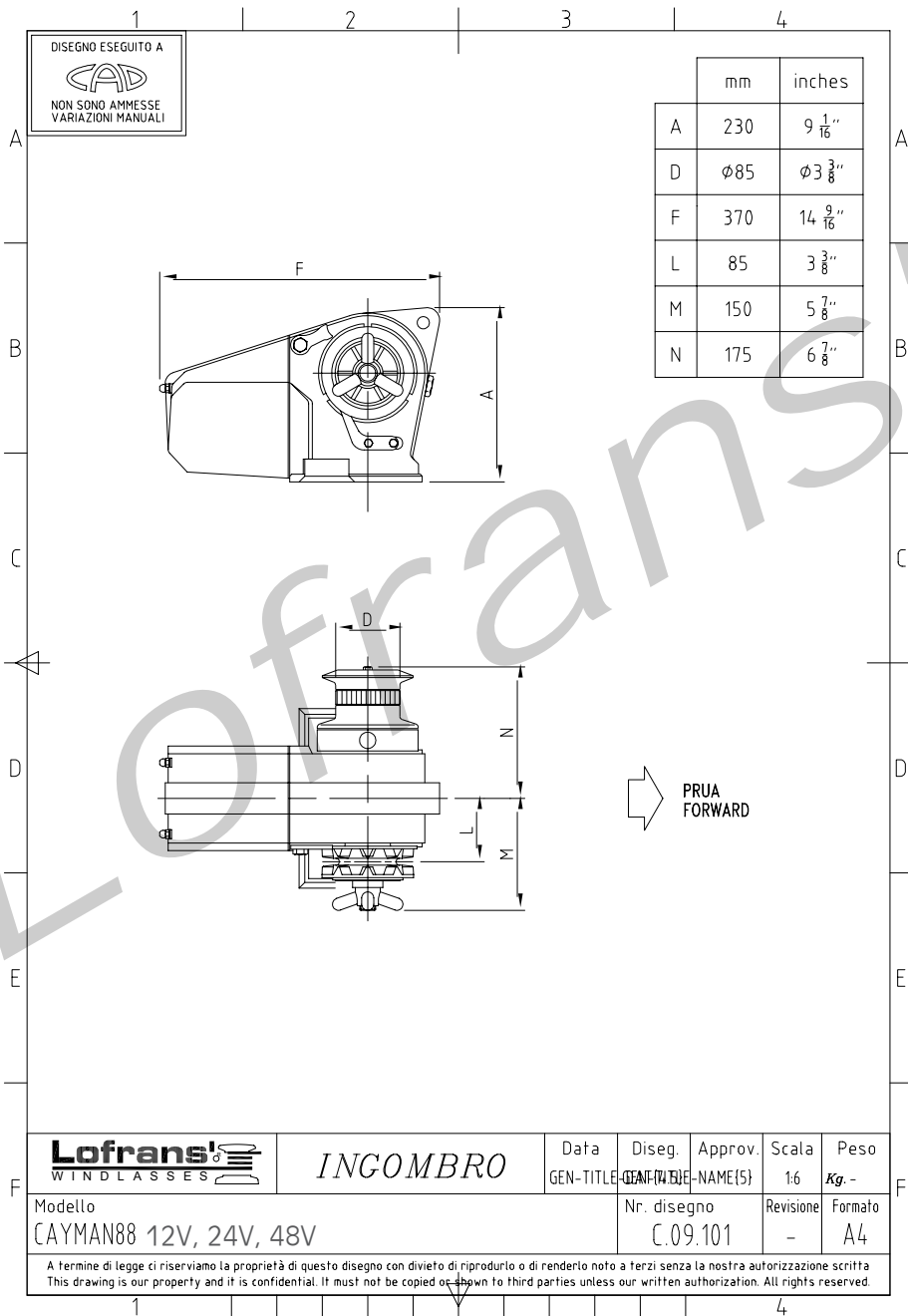
UK

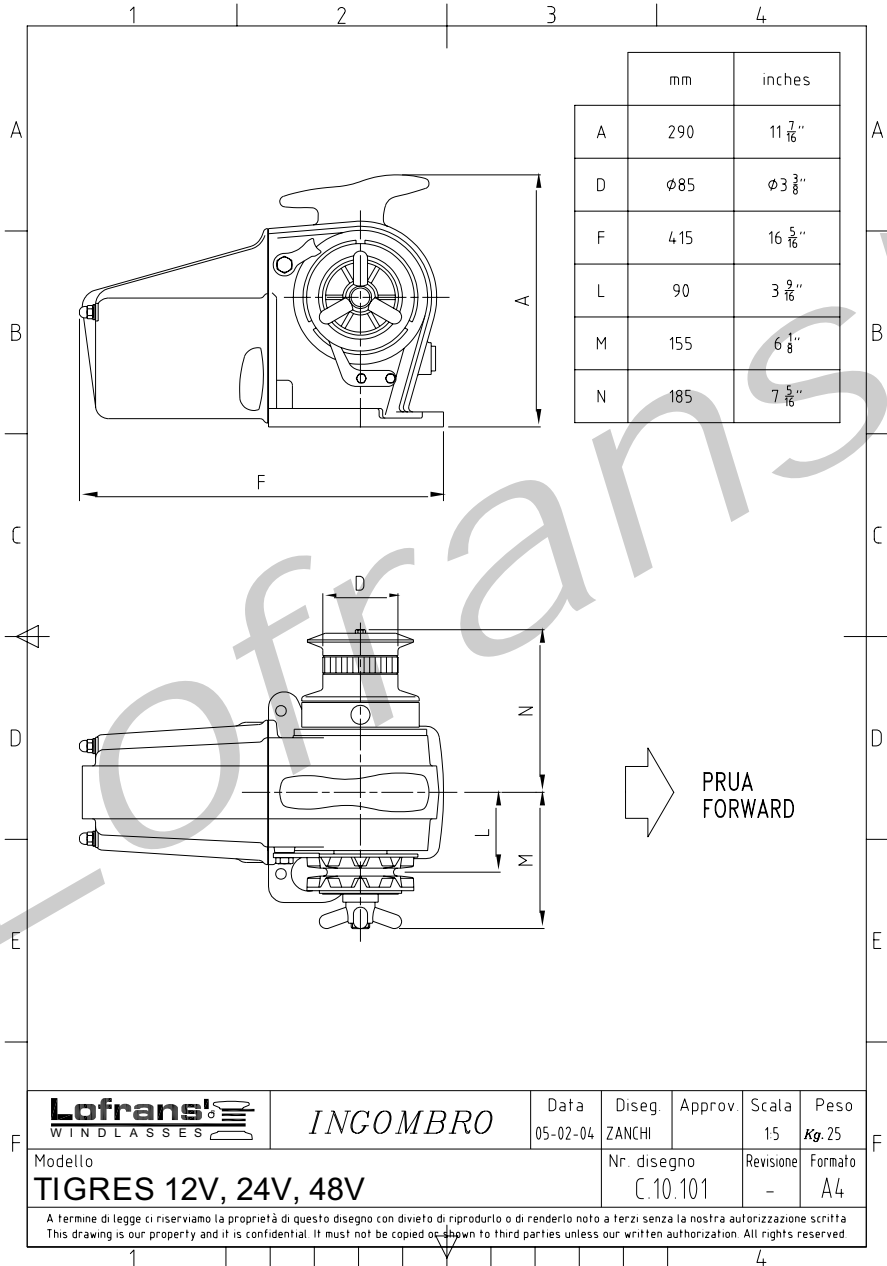

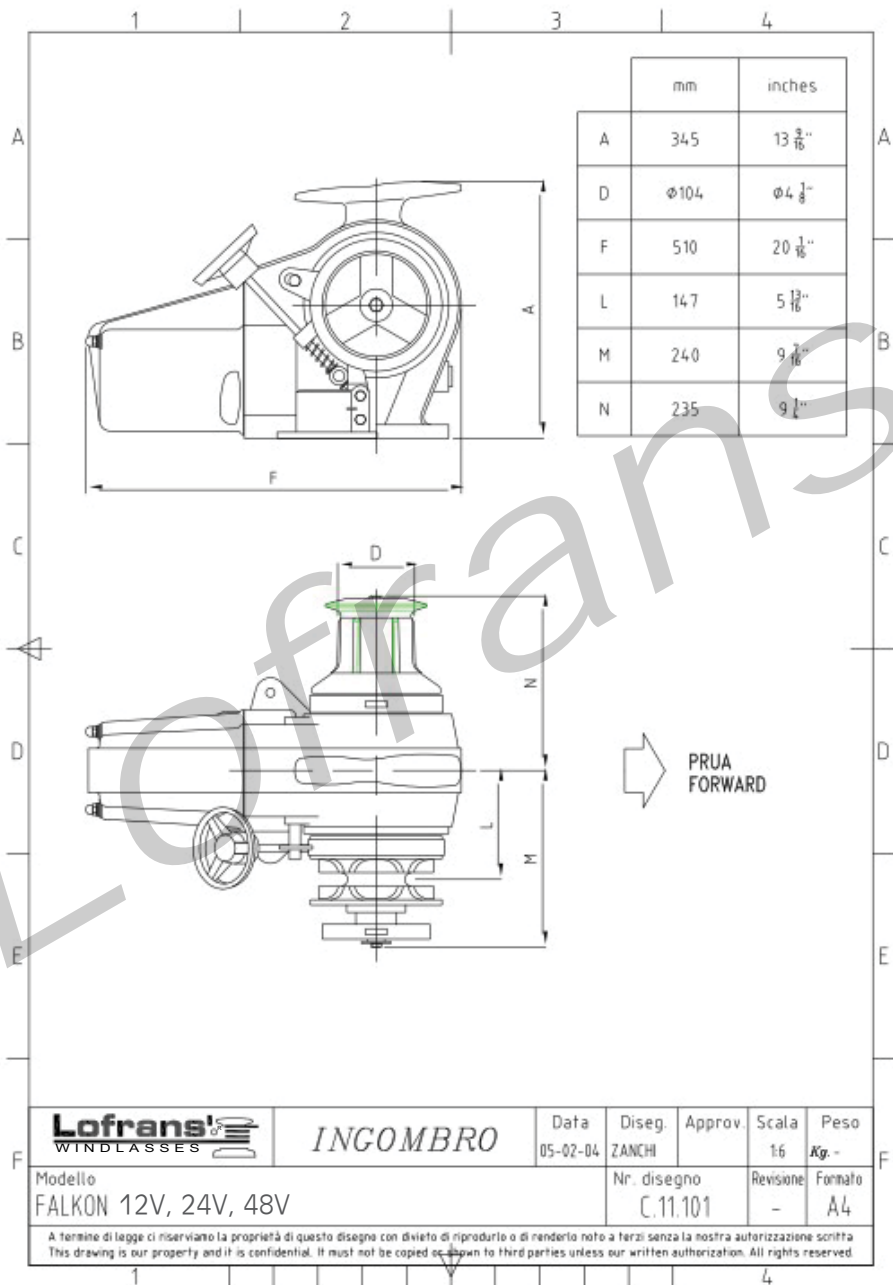

UK

	<p><i>INGOMBRO</i></p>	<p>Data 05-02-04</p>	<p>Diseg. ZANCHI</p>	<p>Approv.</p>	<p>Scala 15</p>	<p>Peso Kg. 25</p>
<p>Modello TIGRES 12V, 24V, 48V</p>		<p>Nr. disegno C.10.101</p>		<p>Revisione -</p>	<p>Formato A4</p>	
<p><small>A termine di legge ci riserviamo la proprietà di questo disegno con divieto di riprodurlo o di renderlo noto a terzi senza la nostra autorizzazione scritta. This drawing is our property and it is confidential. It must not be copied or shown to third parties unless our written authorization. All rights reserved.</small></p>						



11 WARRANTY CONDITIONS

Lofrans" guarantees that in a normal use and by meeting the maintenance programmes, the anchor windlass is covered by a warranty for a period of **3 years** from the date of purchase by the ultimate user, subject to the conditions, limitations, and exceptions listed hereunder. Any product that proves to be defective in a normal use during this period will be repaired or replaced at the choice of Lofrans".

11.1 Conditions and limits

- Lofrans" liability will be limited to the repair or replacement of all parts of the product that show material or processing defects.
- Lofrans" is not liable for the wrong choice of the anchor windlass by the purchaser.
- Lofrans" will not be liable in any whatsoever manner for failures, or any consequent damage deriving from:
 - use of the anchor windlass in an application for which it was not designed or envisaged;
 - corrosion, degradation by UV rays and wear;
 - non-observance of the maintenance plan;
 - wrong or unsuitable installation of the product;
 - any modification or alteration of the product;
 - conditions of use beyond the specifications and the performances of the product:
 - Except for different directives given directly by Lofrans", any product subject to a warranty request must be returned to Lofrans", which will analyse the problem.
 - The warranty does not cover the accessory costs met for interventions, removal, transport, and installation of the product;
 - Maintenance carried out by persons not authorised by Lofrans" will invalidate this warranty;
 - The Lofrans' products are intended to be used only in a marine environment. Lofrans" is not liable should these products be used differently.

UK

11.2 Exceptions

The cover under warranty of the following components is limited to a period of one year from the date of purchase by the ultimate user:

- Electric motors and related electric equipment
- Electronic controls
- Hydraulic pumps, valves, and actuators
- Gaskets and seals
- Products used on charter boats.

11.3 Liability

The liability of Lofrans" on this warranty is intended dependant on meeting the regulations and laws in force. Lofrans" is not liable for any other kind, such as:

- Any loss of turnover, advances, or direct or indirect profits, or any other financial loss;
- Damages, costs or expenses payable to third parties;
- Damages to yachts or equipment;
- Death or personal injuries (unless caused by negligence of Lofrans"). Certain States and Countries do not allow the exclusion or limitation of incidental or consequential damages, therefore the aforementioned limitations or exclusions might not be applicable.

11.4 Procedure

Every request for intervention under warranty will be made promptly and in writing by the ultimate user to the local Lofrans' assistance centre.

11.5 Clause of termination

If any whatsoever clause of this warranty will be invalidated by a Judge or other competent authority, the validity of the remaining clauses of this warranty and the rest of the clause in question will not be affected.

11.6 Compliance

This warranty is governed by the laws and in compliance with the Italian Laws or the State or Country in which the ultimate user is domiciled at the time of purchase of the product.

Lofrans![®] 
WINDLASSES
THE ORIGINAL WINDLASS

Via Philips, 5 - 20052 Monza (MB) (Italy)
www.lofrans.com - e-mail: contact@lofrans.com