

auto electrical parts

Technical Information Sheet

Part No. 0-420-46

A robust 9 x 3 watt 12/24 volt LED work lamp. Low current draw, 1.5 amp at 12 volt dc. Black powder coated die cast aluminum case, polycarbonate lens, supplied with stainless steel adjustable bracket and 300mm flying lead. Protected to IP67. E Marked R10 EMC



Technical Drawing (not to scale)

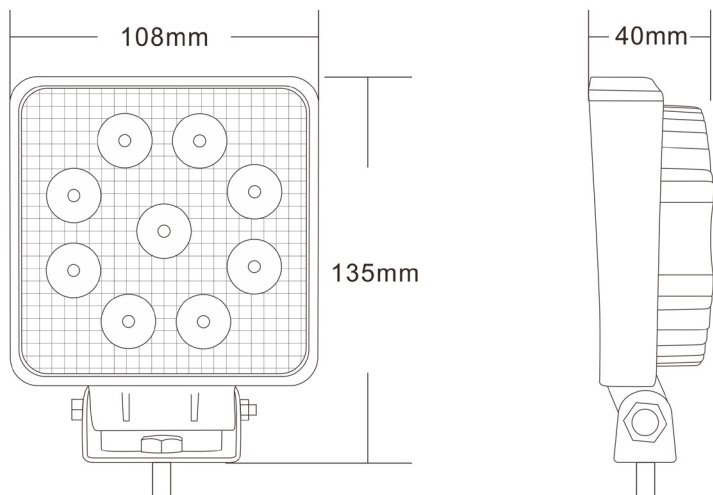

Specification

Type	LED work lamp
Voltage	10-30 volt dc
Current	1.5 amp at 12 volt dc
LEDs	9 x 3W LEDs
Light intensity	1700 lumens
Housing	Die cast aluminium
Bracket	Stainless steel
Lens	Polycarbonate
Degree of protection	IP67
Operating temperature	-40°C to +60°C
Weight	0.400Kg
Dimensions	Please see above diagram
Certificate	E Marked R10 EMC

The information contained in this document is correct to the best of our knowledge at the time of printing. However, specifications may change at any time without notice.