



INSTALLATION INSTRUCTIONS

Accessory	Application	Publication No.
WHEEL STRIPE P/N 08F71-MKC-A10	GL1800B/BD	MII
		Issue Date
		July 2017

Honda Dealer: Please give a copy of these instructions to your customer.

PARTS LIST

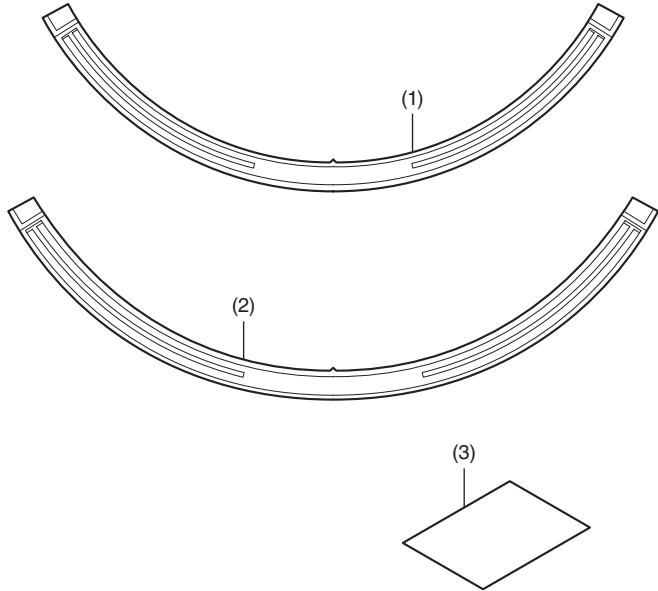

No.	Description	Qty
(1)	Rear wheel stripe	6
(2)	Front wheel stripe	6
(3)	Installation Instructions URL	1

SUPPLIES REQUIRED

- Masking tape
- Scale
- Isopropyl alcohol
- Shop towel

INSTALLATION

▲ CAUTION

- To prevent burns, allow the engine, exhaust system, radiator, etc., to cool before installing the accessory.

NOTE:

- Heat the bonding surfaces with a hair dryer if the ambient air temperature is below 70°F (21°C).
- The adhesive reaches full strength in 72 hours. Wait at least 24 hours before riding your motorcycle.
- To neatly attach this accessory, attach it while lifting the tire with the maintenance stand or similar and adjusting the space between the wheel stripe and rim.
- Attach the three wheel stripes to the one side of the wheel as shown.

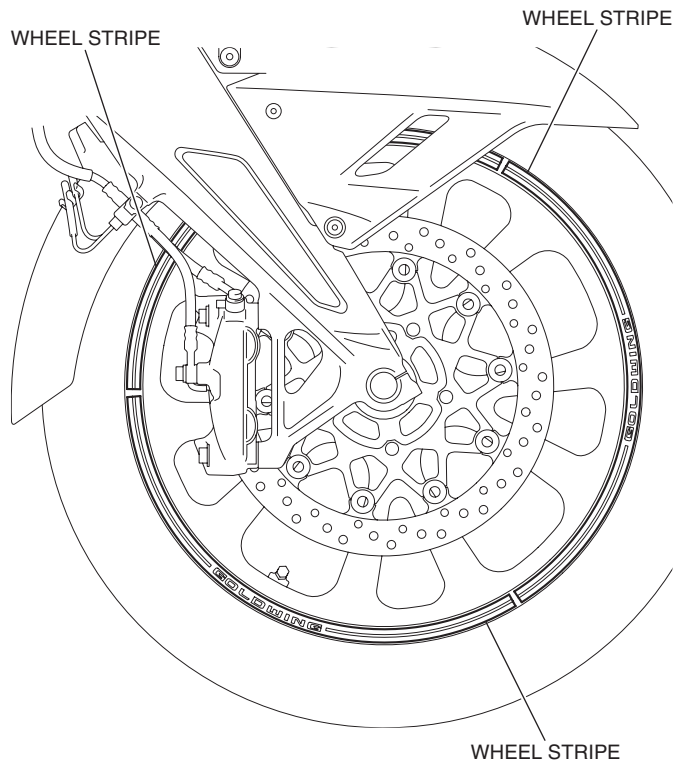

1. Clean the surface of the area shown using an isopropyl alcohol.

<Right side>

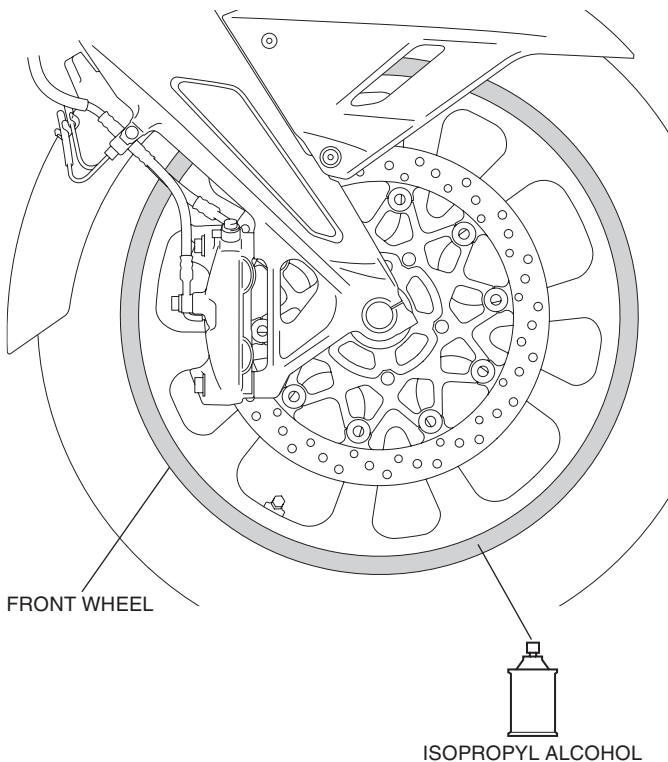

2. Temporarily install the front wheel stripe as shown.

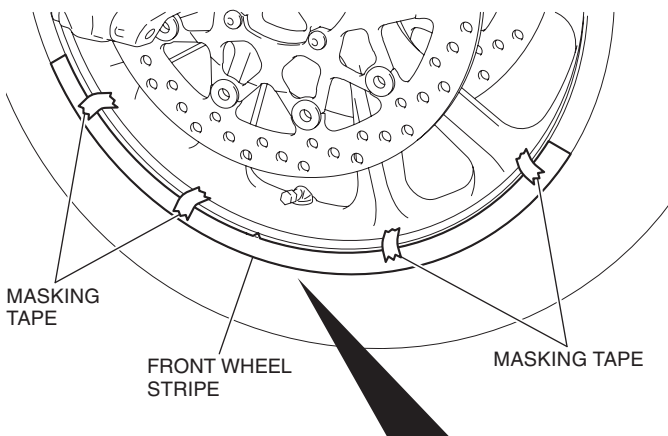

Temporarily install the front wheel stripe with the center of the rim.

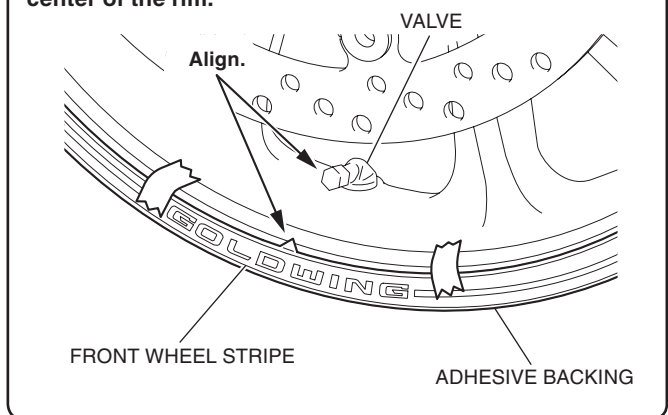

3. Partly remove the adhesive backing from behind the front wheel stripe as shown.

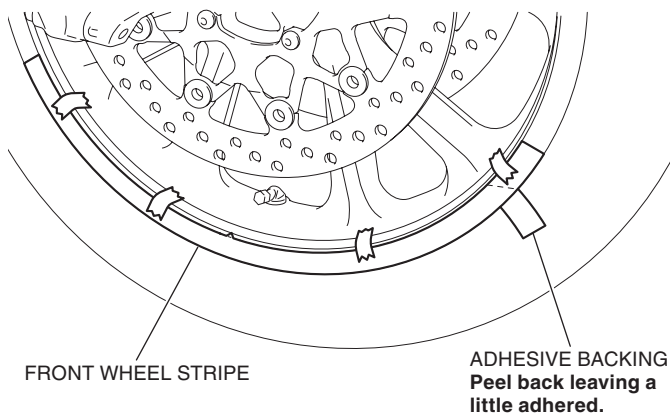

4. Attach the front wheel stripe as shown.
 - Being careful not to allow air bubbles, glue on the wheel stripe while adjusting the space between the wheel stripe and the rim.
 - Do not glue on while pulling and stretching the stripe.

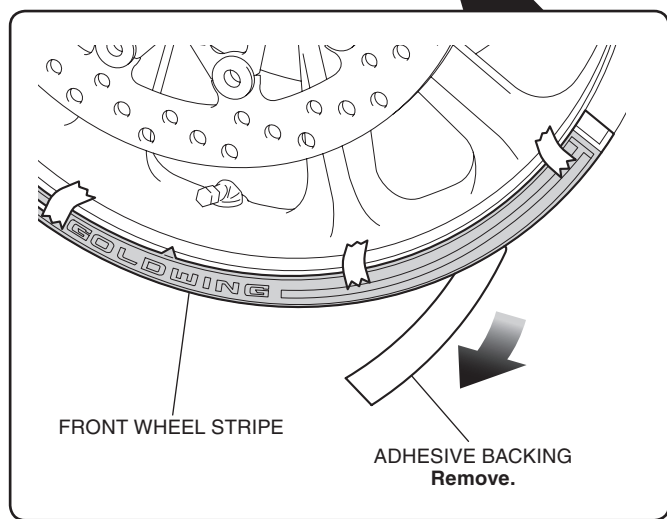
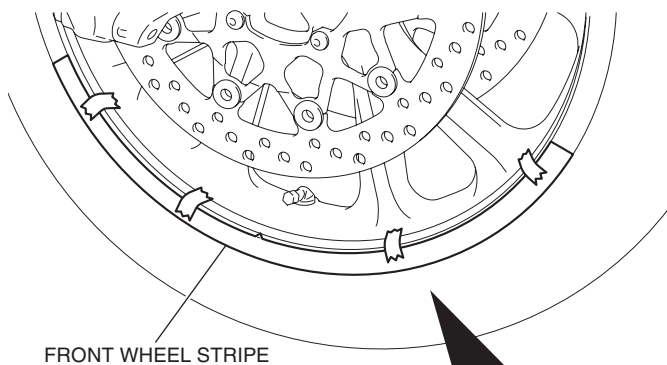

5. Using a shop towel, force out excessive air.

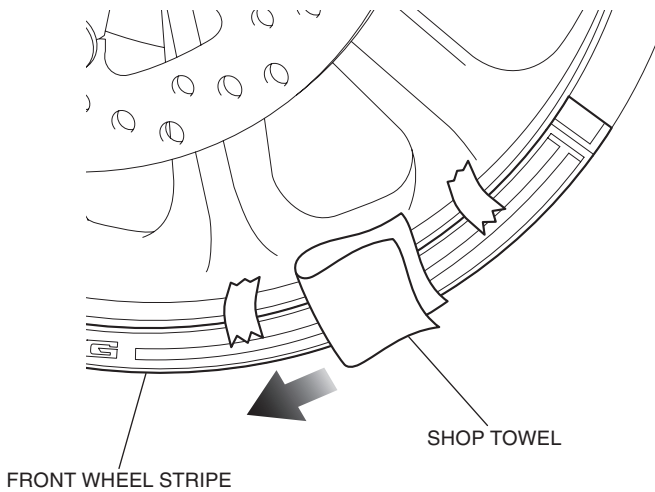

6. Remove the masking tape and application film as shown.

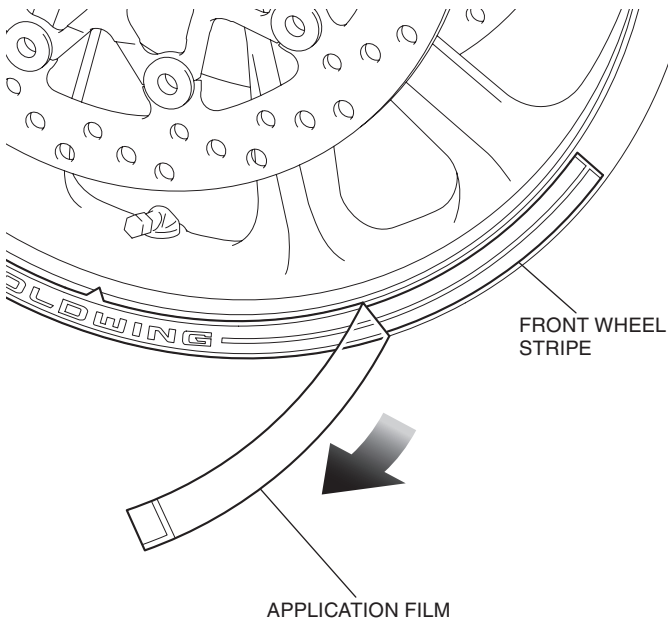

7. Temporarily install the second and third front wheel strips in the same manner as the first front wheel strip.

- **Equalize three gaps between the front wheel stripes as shown.**

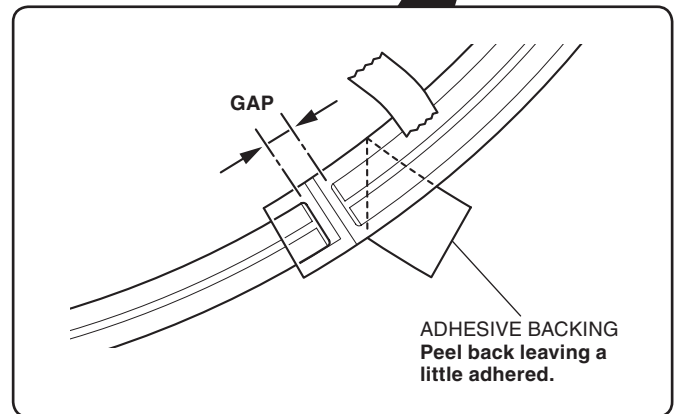
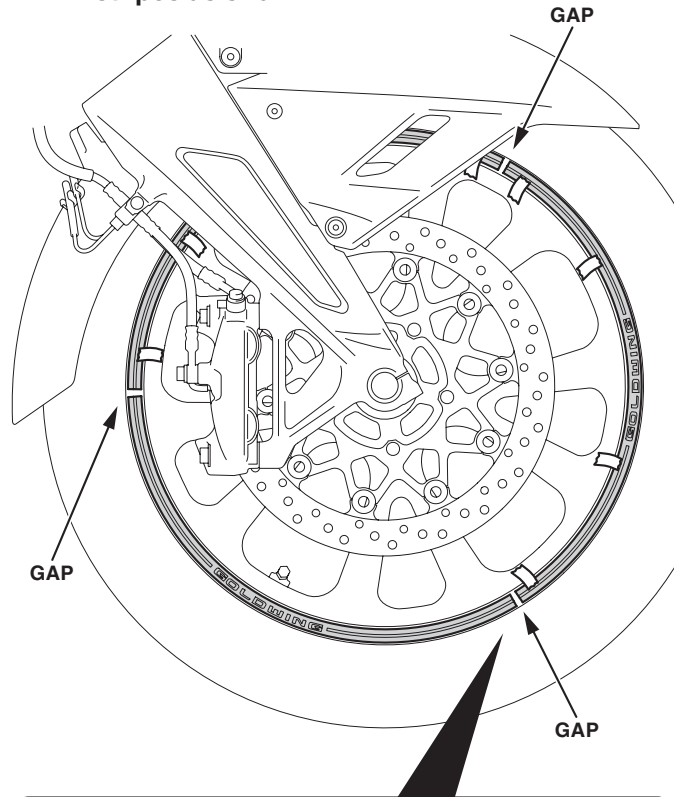

8. Attach the second and third front wheel strip in the same manner as the first front wheel strip.

9. Install the left side of the front wheel stripe in the same manner as the right side.

- **Install the right side of the front wheel stripe in the same position as the left side.**

10. Install the rear wheel stripe in the same manner as the front side.