



INSTALLATION INSTRUCTIONS

Accessory
CHROME FRONT CALIPER COVER
 P/N 08F73-MKC-A00
FRONT CALIPER COVER
 P/N 08F74-MKC-A00

Application
GL1800/B/BD/D/DA

Publication No.
MII
 Issue Date
July 2017

Honda Dealer: Please give a copy of these instructions to your customer.

PARTS LIST

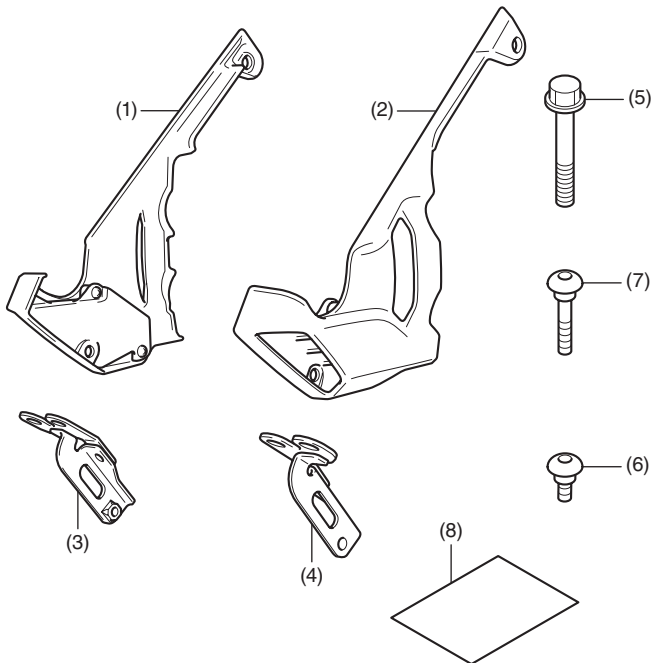

No.	Description	Qty
(1)	Right front caliper cover	1
(2)	Left front caliper cover	1
(3)	Right stay	1
(4)	Left stay	1
(5)	8 mm flange bolt	4
(6)	5 mm screw	2
(7)	6 mm screw	2
(8)	Installation instructions URL	1

TOOLS REQUIRED

Socket (10mm)
 Ratchet
 Hex wrench (5 mm)
 Torque wrench

TORQUE CHART

Tighten all screws, bolts, and nuts to their specified torque values. Refer to the Service Manual for the torque values of the removed parts.

Item	N-m	kgf-m	lbf-ft
5 mm screw	4.2	0.4	3.1
6 mm screw	10	1.0	7
8 mm flange bolt	22	2.2	16

INSTALLATION

▲ CAUTION

- To prevent burns, allow the engine, exhaust system, radiator, etc., to cool before installing the accessory.

- Remove the bolts as shown.

<Left side>

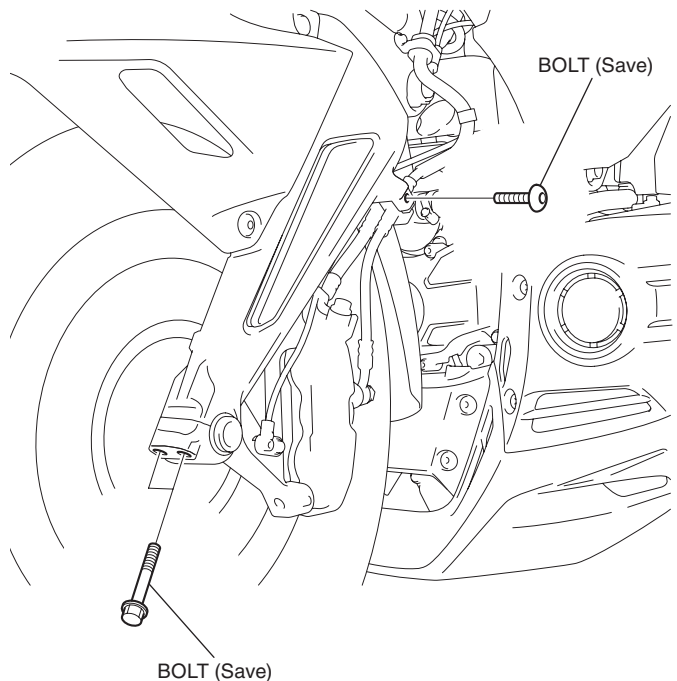

- Install the left stay as shown.

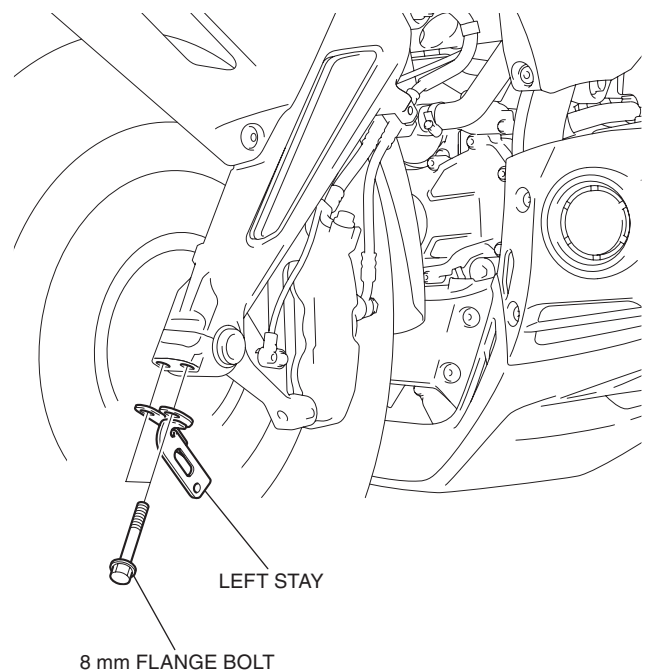

3. Install the left front caliper cover as shown.

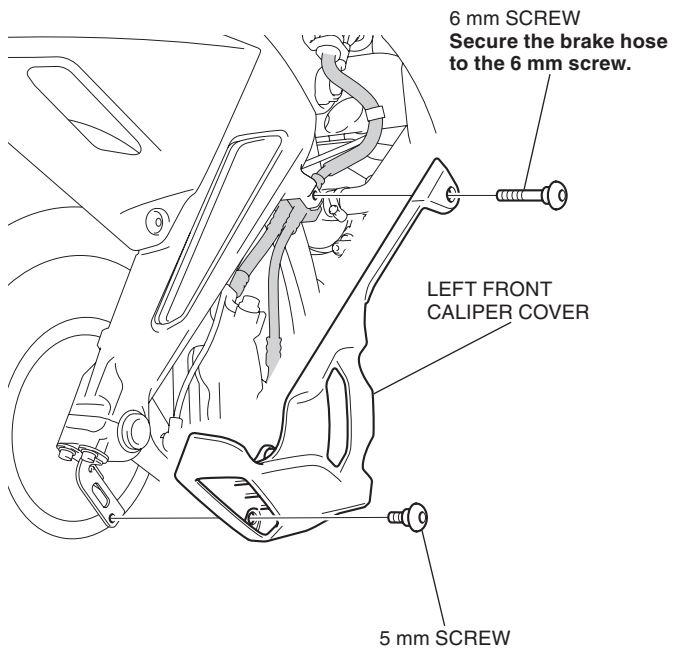

4. Install the right stay and right front caliper cover in the same manner as the left side.