



INSTALLATION INSTRUCTIONS

Accessory

CHROME TRUNK RACK
P/N 08L70-MKC-A00

Application

GL1800/B/BD/D/DA

Publication No.

MII

Issue Date

September 2017

Honda Dealer: Please give a copy of these instructions to your customer.

PARTS LIST

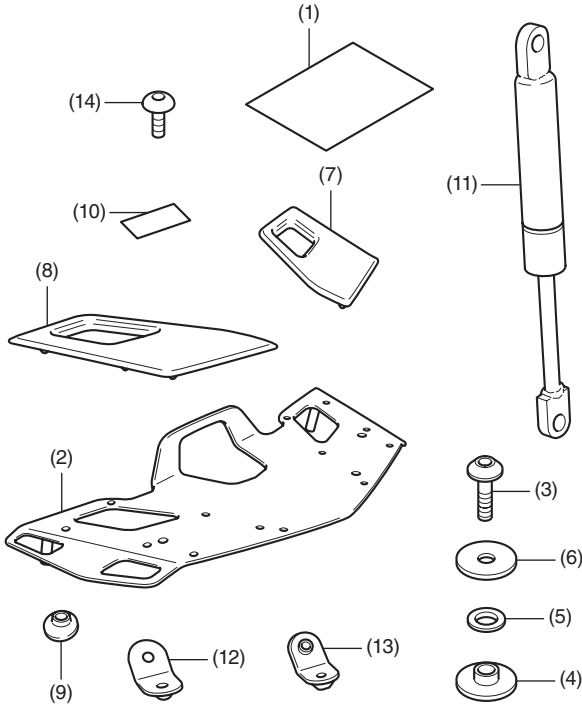

| No. | Description | Qty |
|------|-------------------------------|-----|
| (1) | Installation Instructions URL | 1 |
| (2) | Trunk rack | 1 |
| (3) | 6 mm bolt | 4 |
| (4) | Collar | 2 |
| (5) | Rubber washer | 4 |
| (6) | Washer | 2 |
| (7) | Right rack top cover | 1 |
| (8) | Left rack top cover | 1 |
| (9) | Grommet | 4 |
| (10) | Label | 1 |
| (11) | Damper | 2 |
| (12) | Lower plate | 2 |
| (13) | Upper plate | 2 |
| (14) | 6 mm screw | 2 |

TOOLS AND SUPPLIES REQUIRED

- Hex wrench (5 mm)
- Electric drill
- Drill bit (10 mm)
- Hole saw (19 mm)
- Scale
- Masking tape
- Isopropyl alcohol
- Synthetic detergent solution
(Water : Synthetic detergent / 100 : 1)
- Shop towel
- Torque wrench

TORQUE CHART

Tighten all screws, bolts, and nuts to their specified torque values. Refer to the Service Manual for the torque values of the removed parts.

| Item | N·m | kgf·m | lbf·ft |
|------------|-----|-------|--------|
| 6 mm screw | 9 | 0.9 | 6.6 |
| 6 mm bolt | 10 | 1.0 | 7 |

MAXIMUM LOADING CAPACITY

- The weight of the cargo must not exceed the following maximum loading capacity:

| Maximum Loading Capacity | |
|--------------------------|-----------------|
| Chrome trunk rack | 5.0 lb (2.3 kg) |

INSTALLATION

▲ CAUTION

- To prevent burns, allow the engine, exhaust system, radiator, etc., to cool before installing the accessory.

NOTE:

- Heat the bonding surfaces with a hair dryer if the ambient air temperature is below 70°F (21°C).
- The adhesive reaches full strength in 72 hours. Wait at least 24 hours before riding your motorcycle.
- Disconnect the negative (-) connector from the battery before installing this accessory.
- The memories of the clock will be erased when you disconnect the battery. Reset the memories after reconnecting the battery.
- Reinstall the removed parts on the motorcycle and make sure that the wires and harnesses are not pinched.

1. Open the left saddlebag lid as shown.
 - Repeat on the right side.

<Left side>

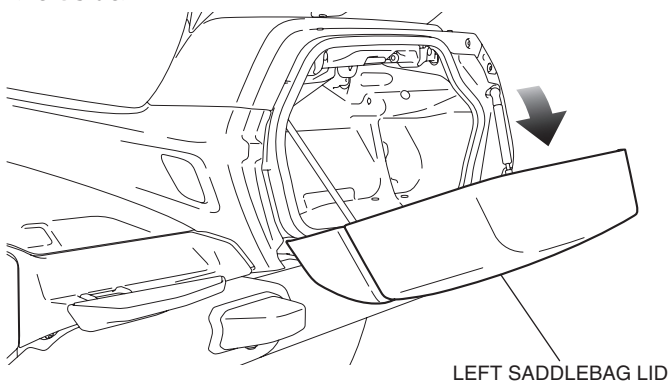

2. Remove the left side cover as shown, and disconnect the negative (-) cable of the battery.

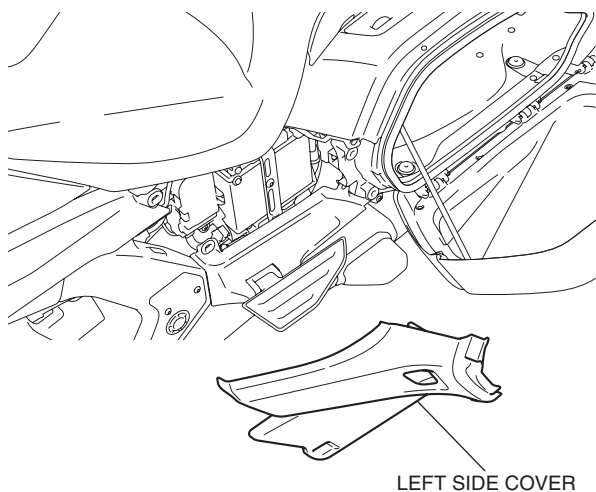

3. Remove the right side cover in the same manner as the left side.
4. Remove the seat as shown.
 - Disconnect the connector for GL1800/D/DA.

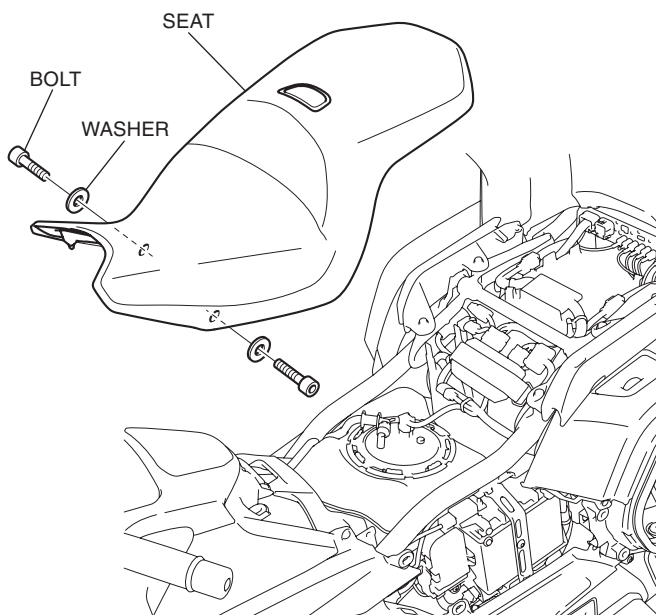

5. Remove the right and left passenger grip as shown.

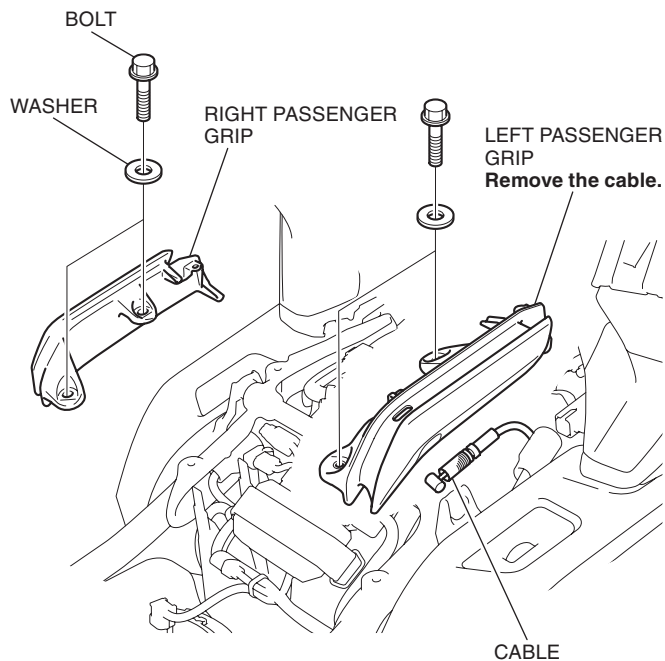

6. Open the rear trunk lid as shown.
 - Refer to the Owner's Manual and using an emergency trunk cable to open the rear trunk lid.

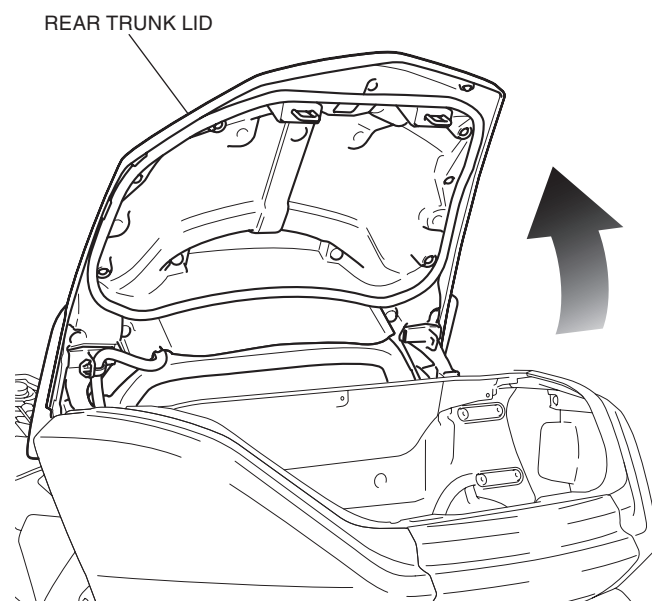

7. Remove the parts as shown.
 • Repeat on the right side.

<Left side> GL1800/B/BD/D

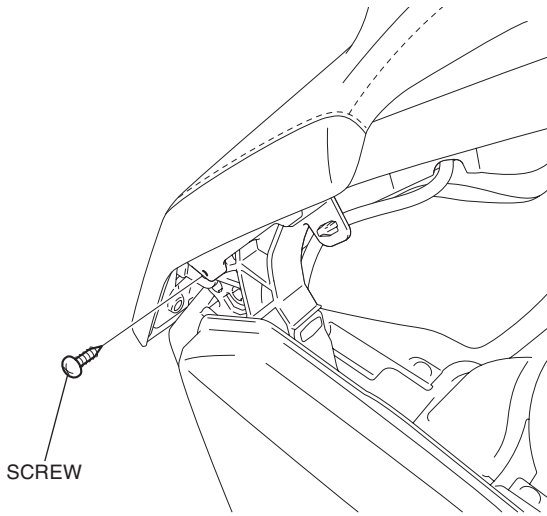

<Left side> GL1800DA

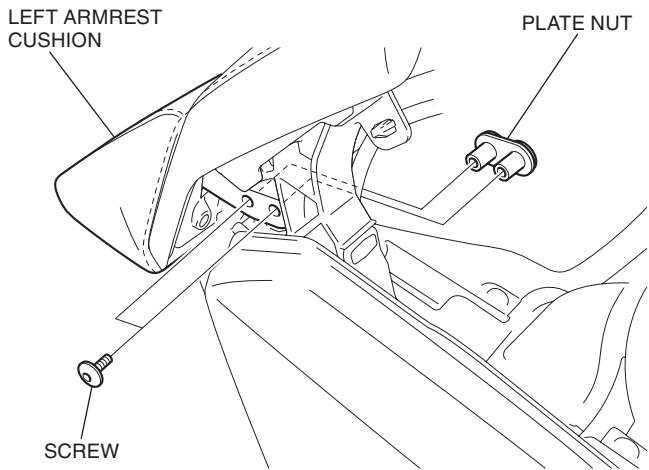

8. Remove the back seat as shown.

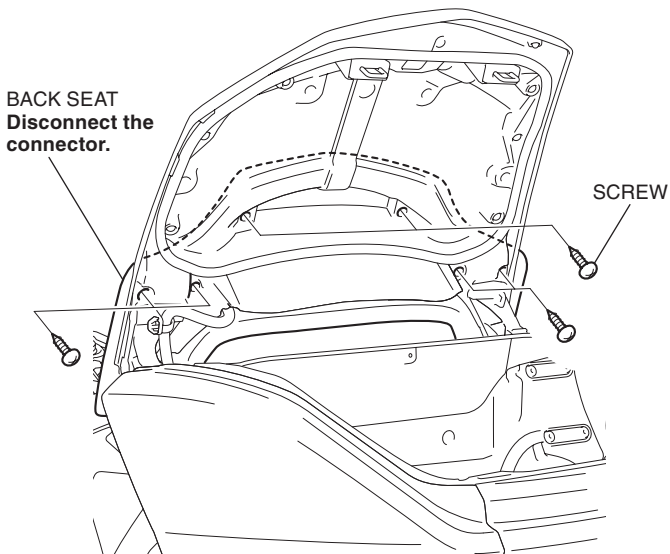

9. Remove the harness as shown.

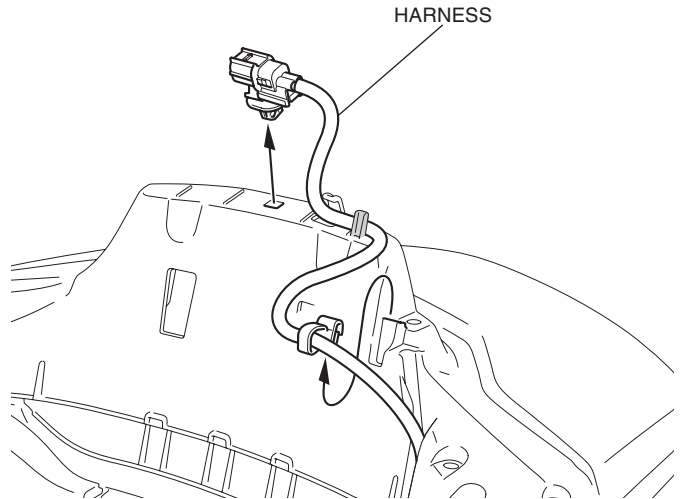

10. Remove the rear trunk lid as shown.

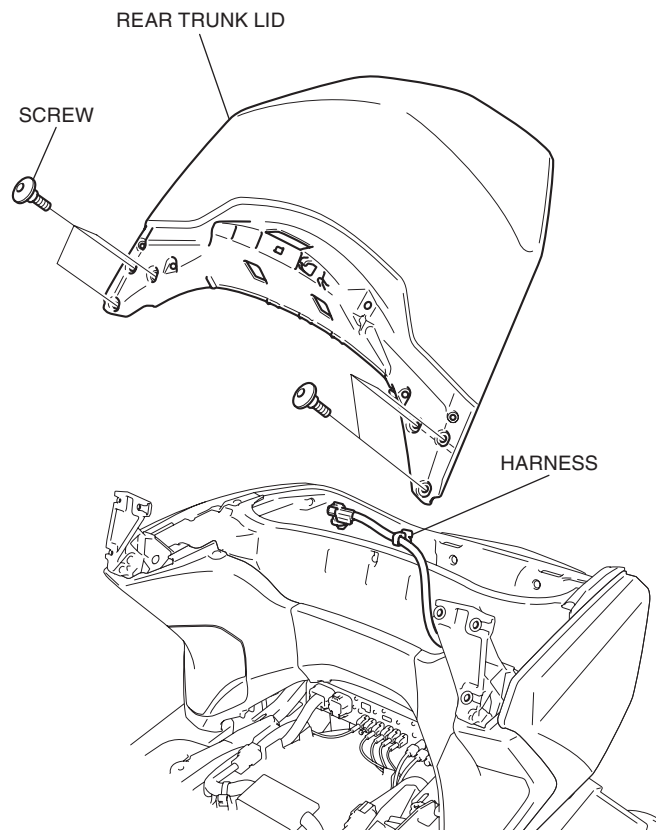

11. Remove the USB code as shown.
- Perform this step on GL1800DA only.

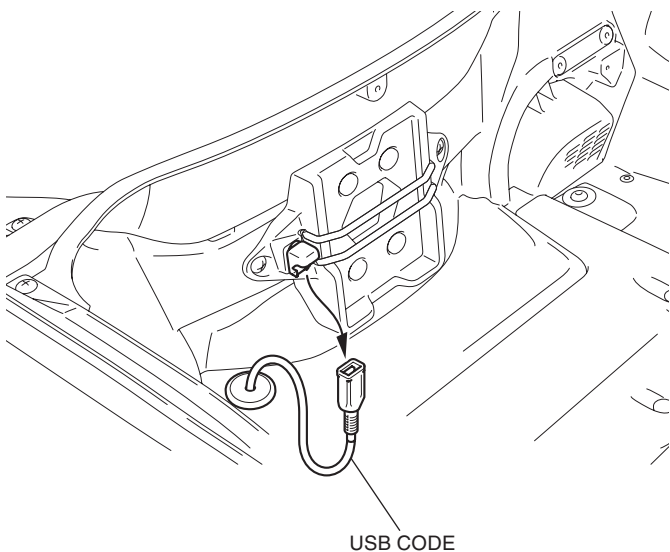

12. Remove the parts as shown.

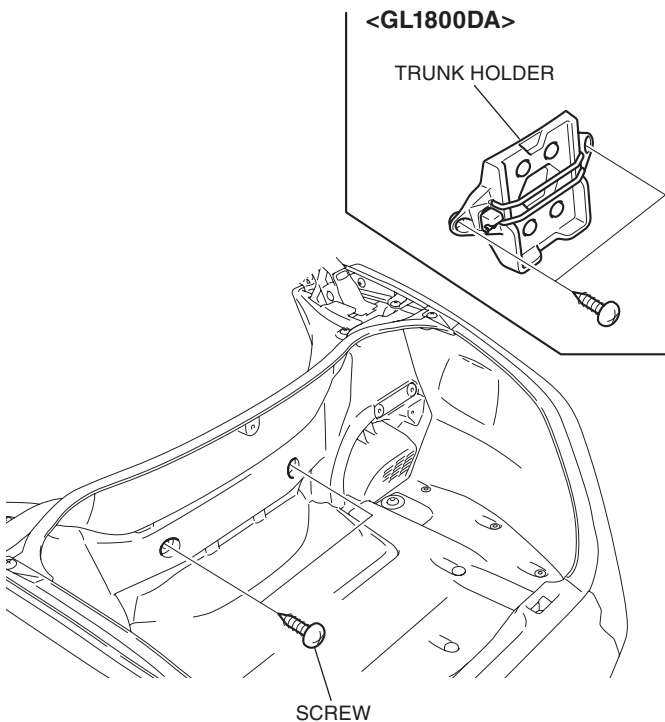

13. Remove the front trunk lower panel as shown.

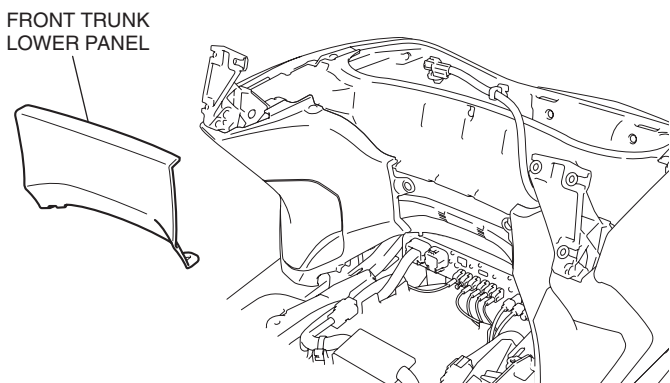

14. Remove the parts as shown.
- Repeat on the left side.

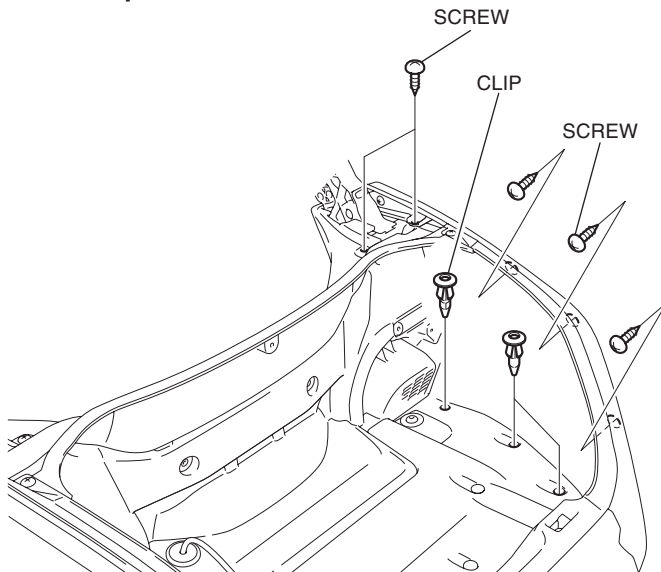

15. Remove the right trunk side cover as shown.
- Repeat on the left side.

<Right side>

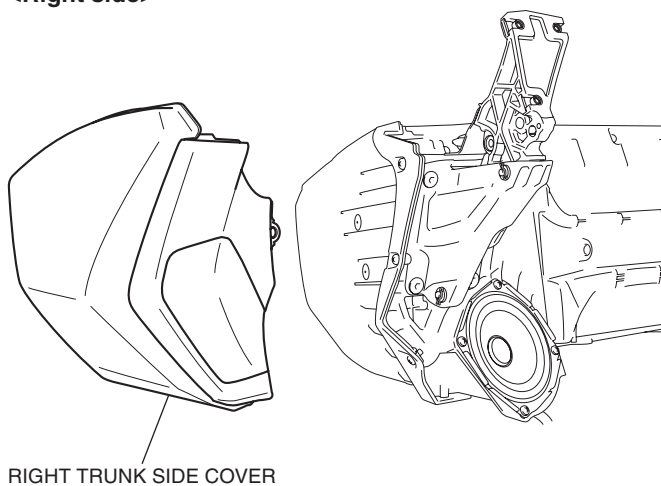

16. Remove the clip as shown.

<Left side>

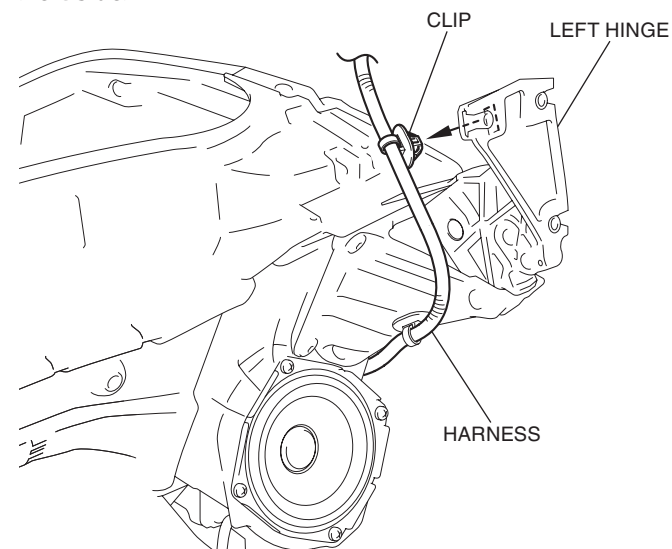

17. Remove the hinge rubber as shown.

- Repeat on the left side.

<Right side>

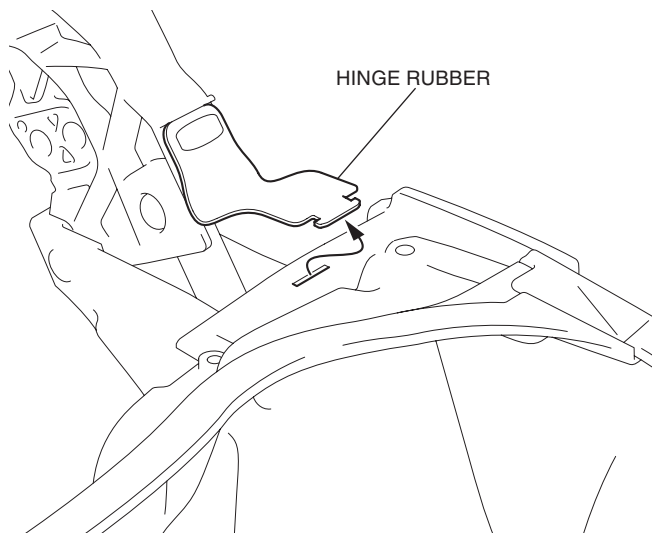

18. Remove the right trunk hinge as shown.

<Right side>

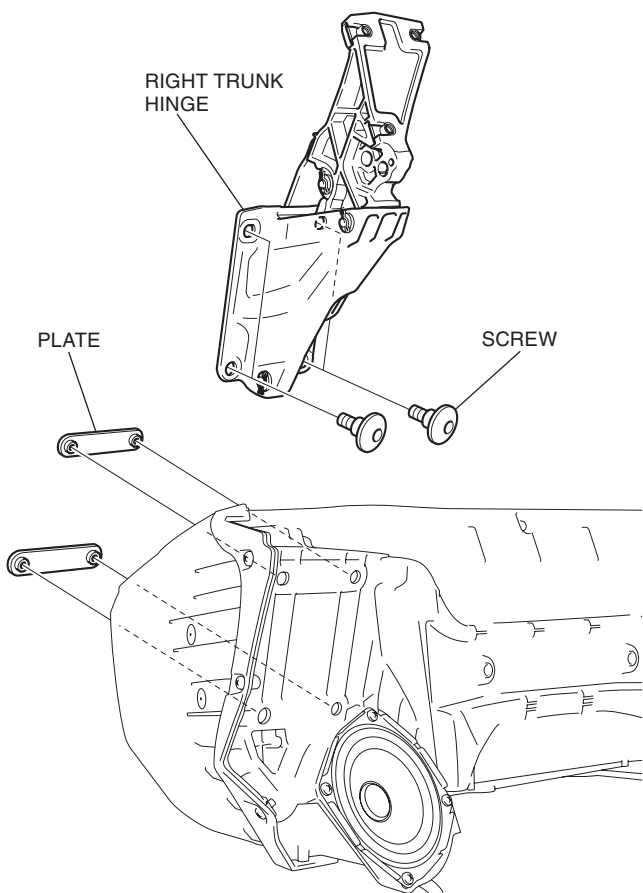

19. Remove the right hinge as shown.

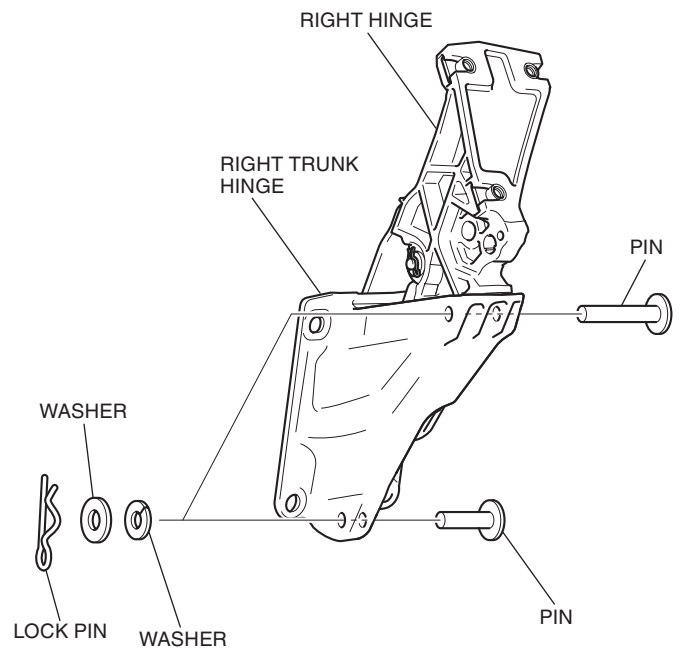

20. Remove the damper as shown.

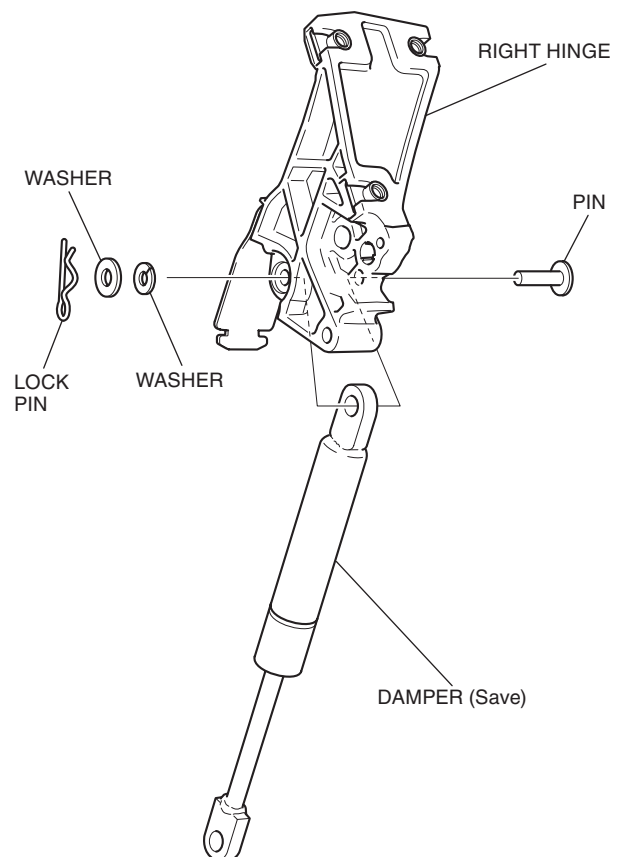

21. Remove the left trunk hinge, left hinge and damper in the same manner as the right side.

22. Remove the clip as shown.

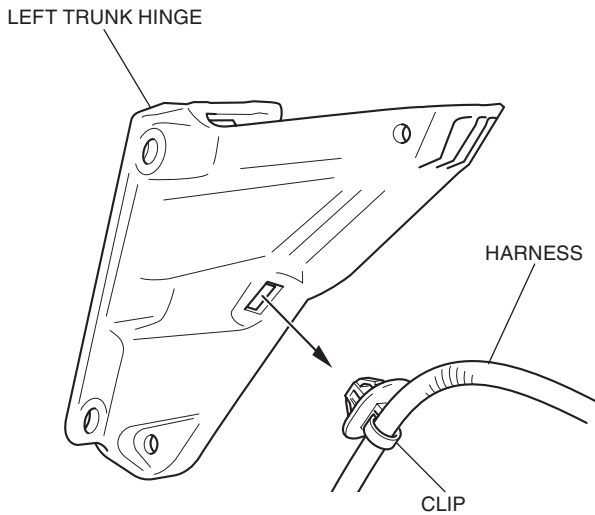

23. Install the damper of the accessory as shown.

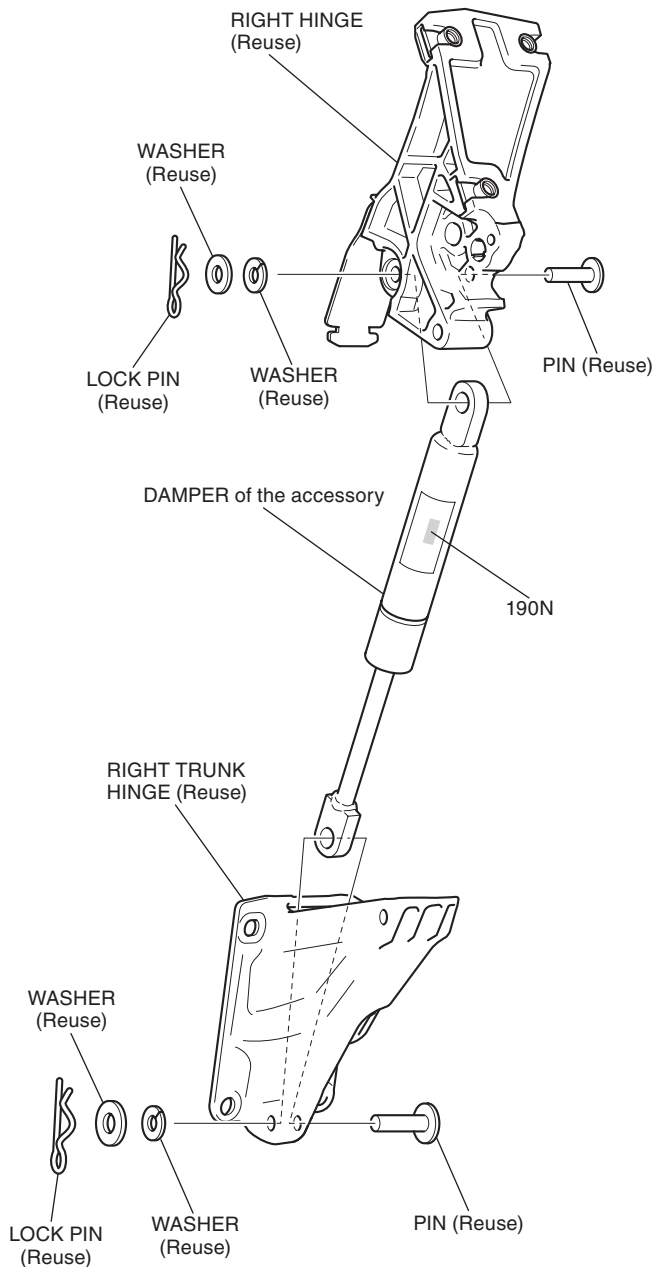

24. Install the right hinge as shown.

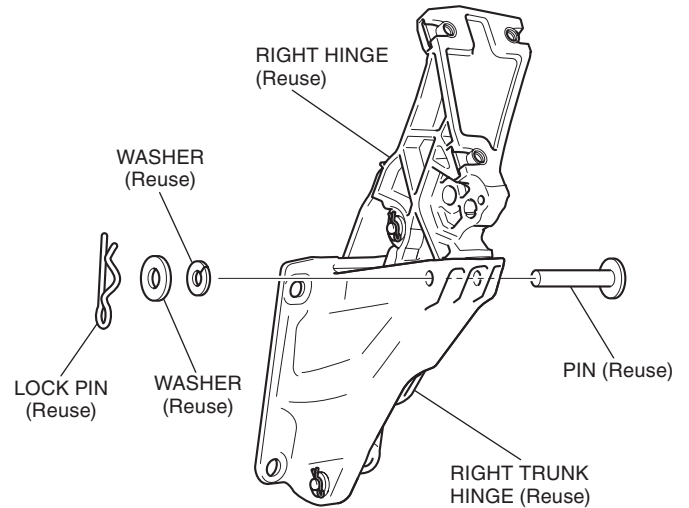

25. Install the damper of the accessory and left hinge in the same manner as the right side.

26. Install the right and left trunk hinge and hinge rubber in the reverse order of removal.

27. Install the harness in the reverse order of removal.

28. Remove the striker rods as shown.

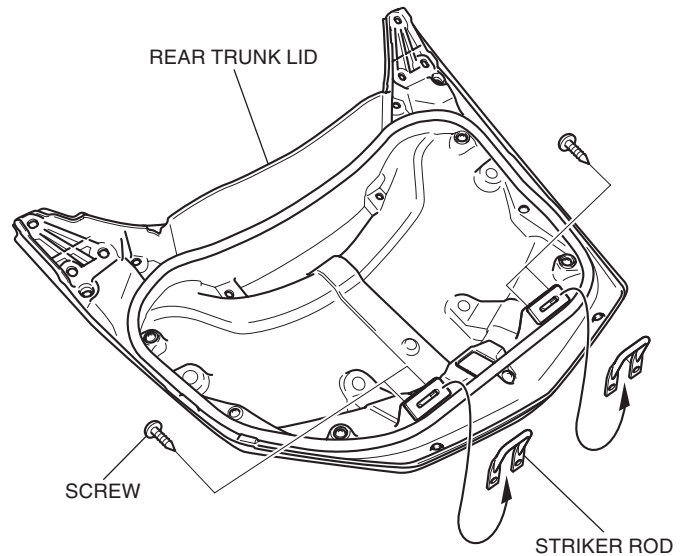

29. Remove the inner trunk lid as shown.

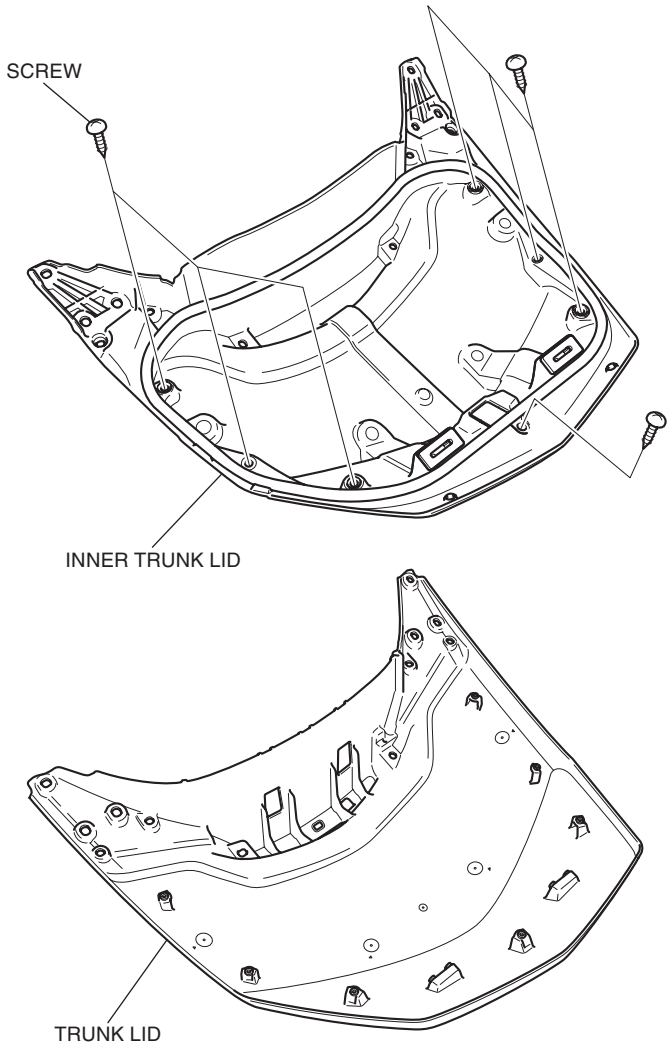

30. Drill at the marked points of the inner trunk lid as shown.

- Remove the any burrs from the edge of the hole.

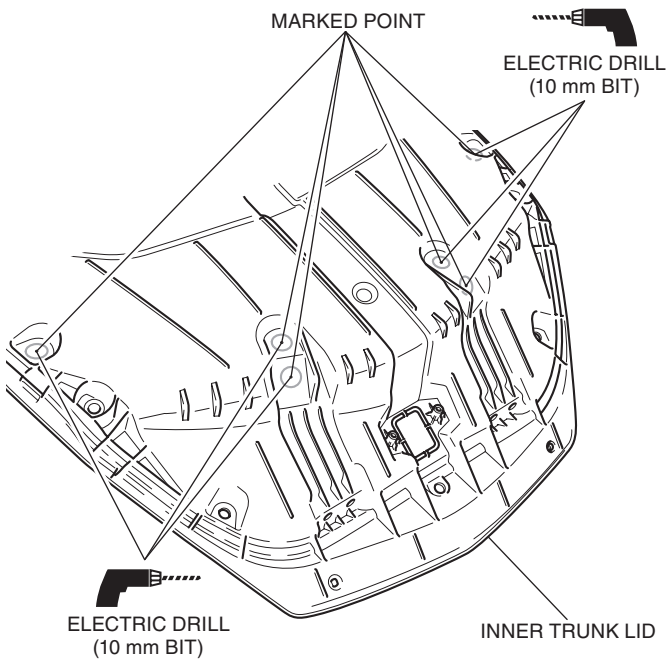

31. Drill at the marked points of the trunk lid as shown.

- Remove the any burrs from the edge of the hole.

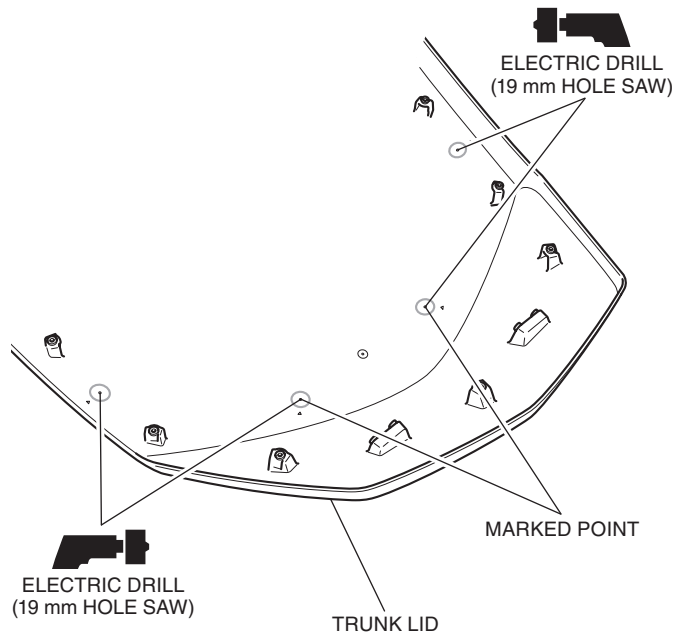

32. Install the grommets as shown.

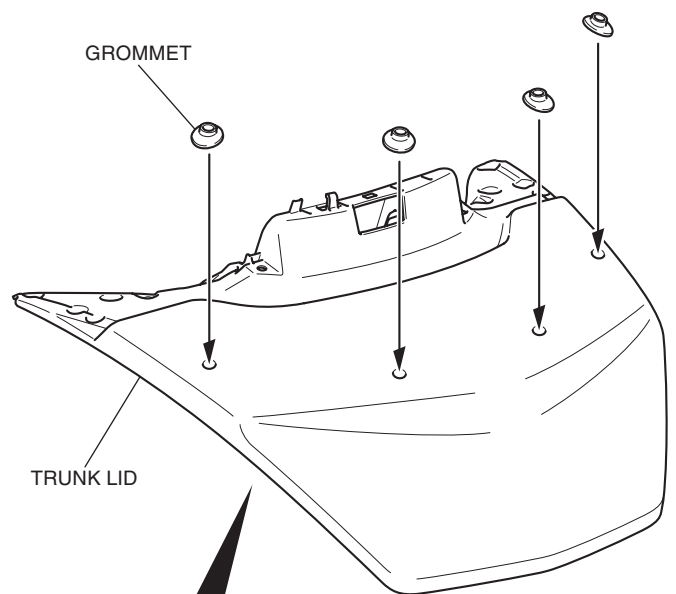

Align the projection of the grommet with the mark of the trunk lid.
<Back side>

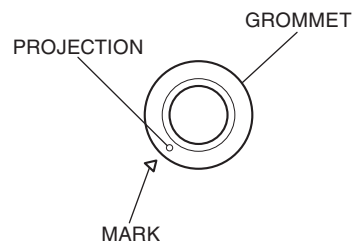

33. Attach the label as shown.

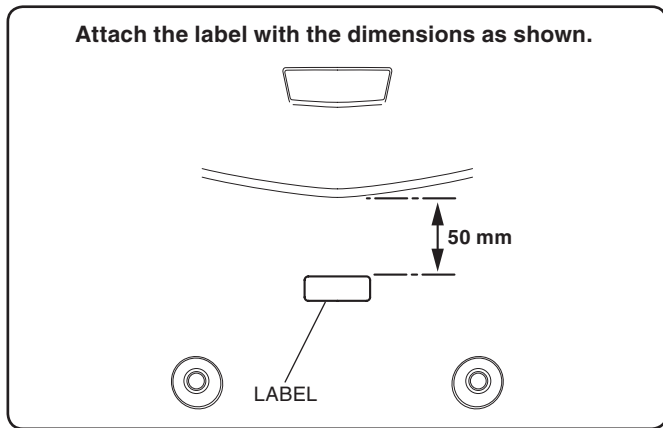

LABEL
Remove the adhesive backing before attaching.

TRUNK LID

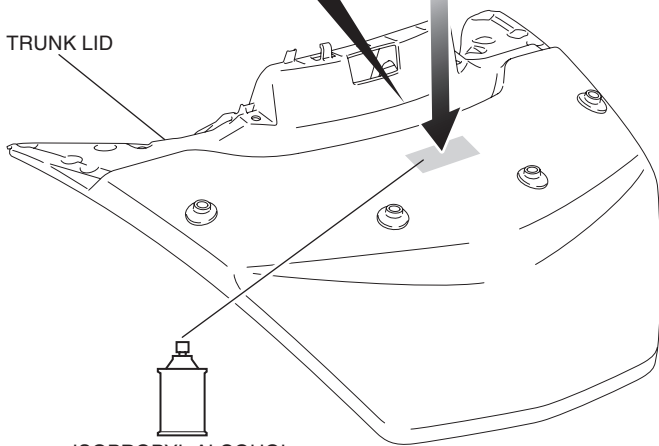

ISOPROPYL ALCOHOL
Thoroughly clean the area where the label will be attached.

34. Place the rubber washers as shown.

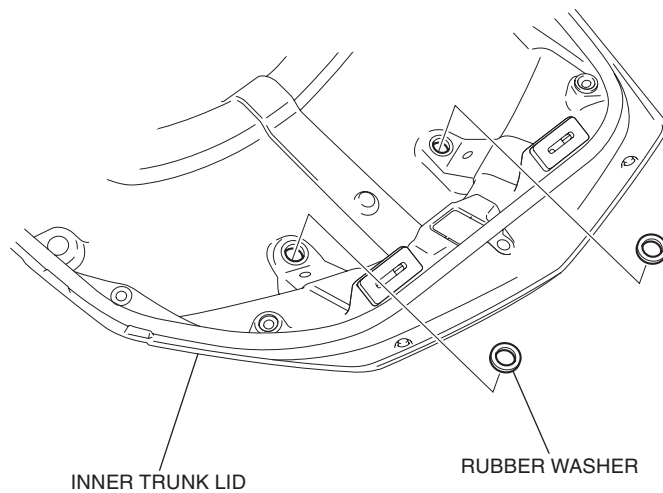

35. Install the lower plates and upper plates as shown.

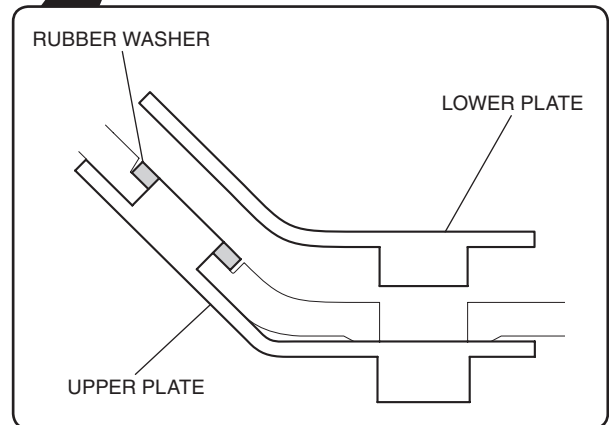
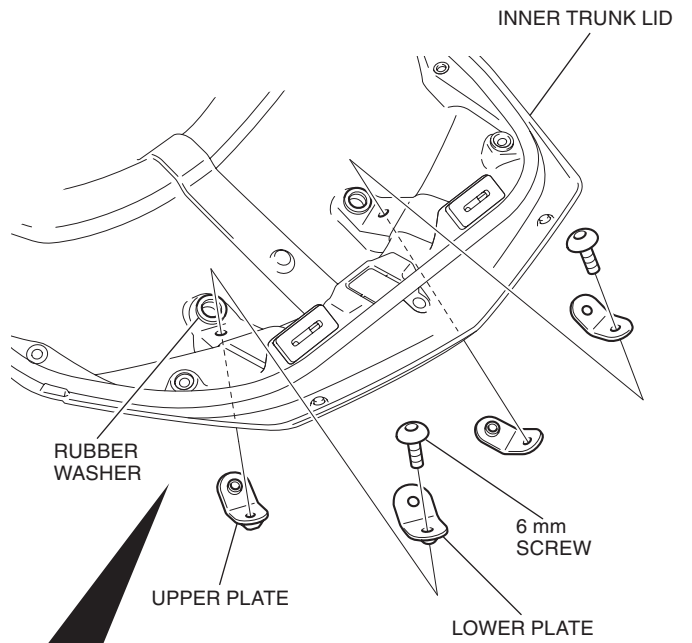

36. Install the collars as shown.

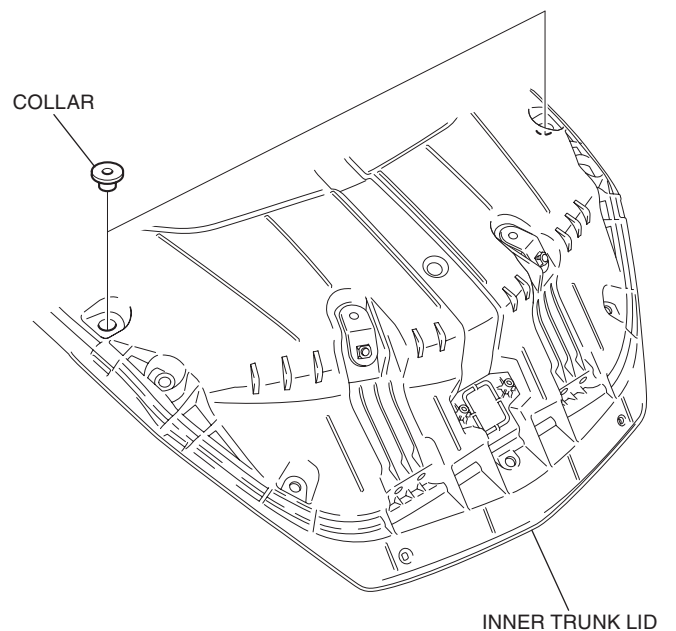

37. Clean the surface of the area shown using an isopropyl alcohol.

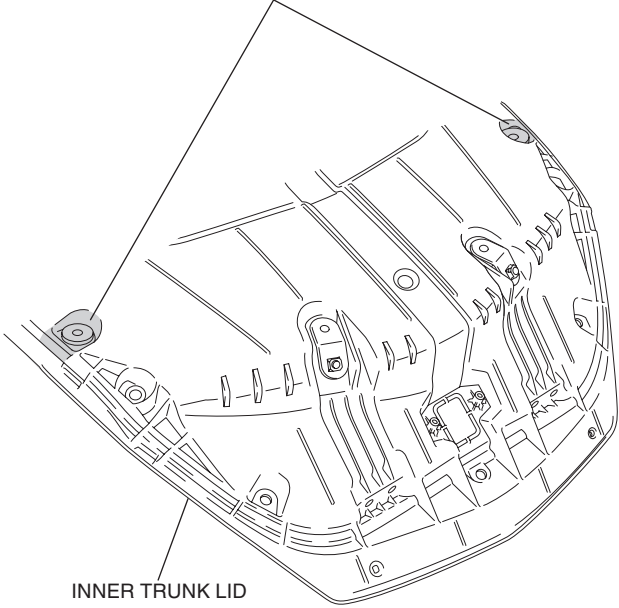

38. Attach the masking tape as shown.
 • Repeat on the right side.

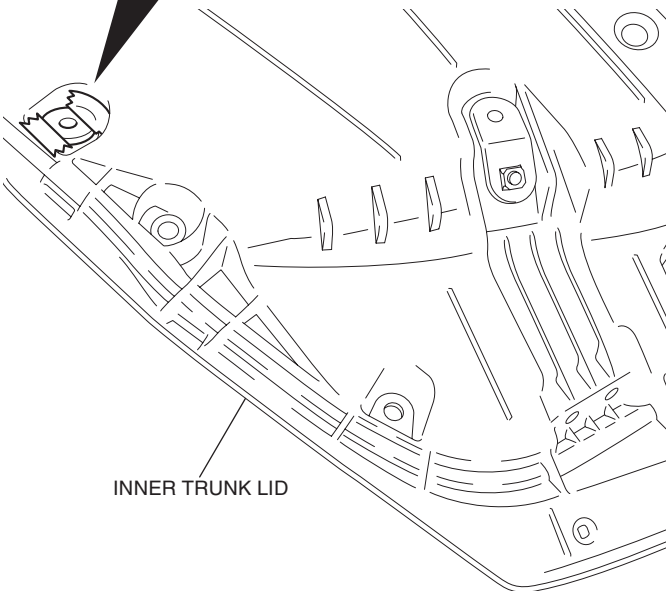
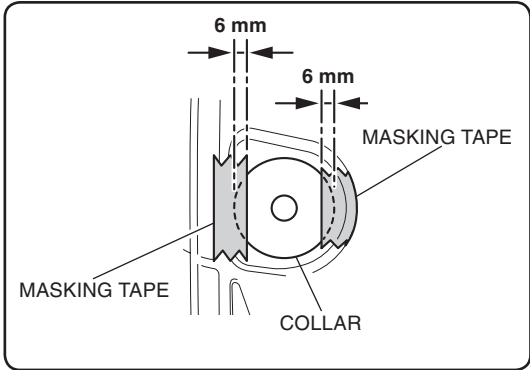

39. Install the inner trunk lid to the trunk lid as shown.

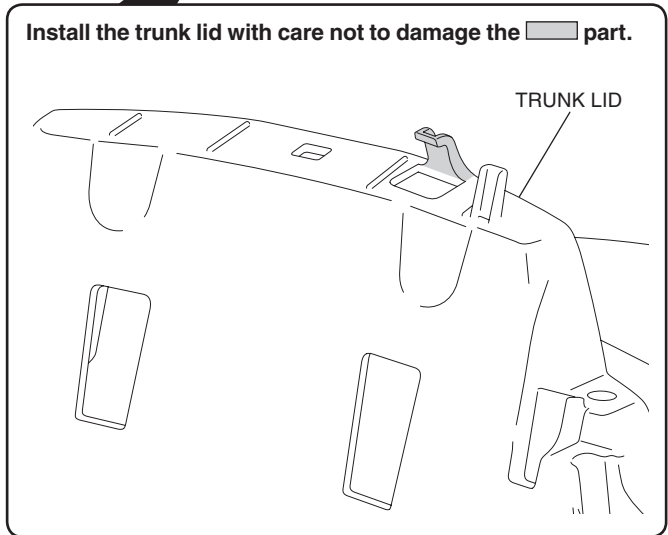
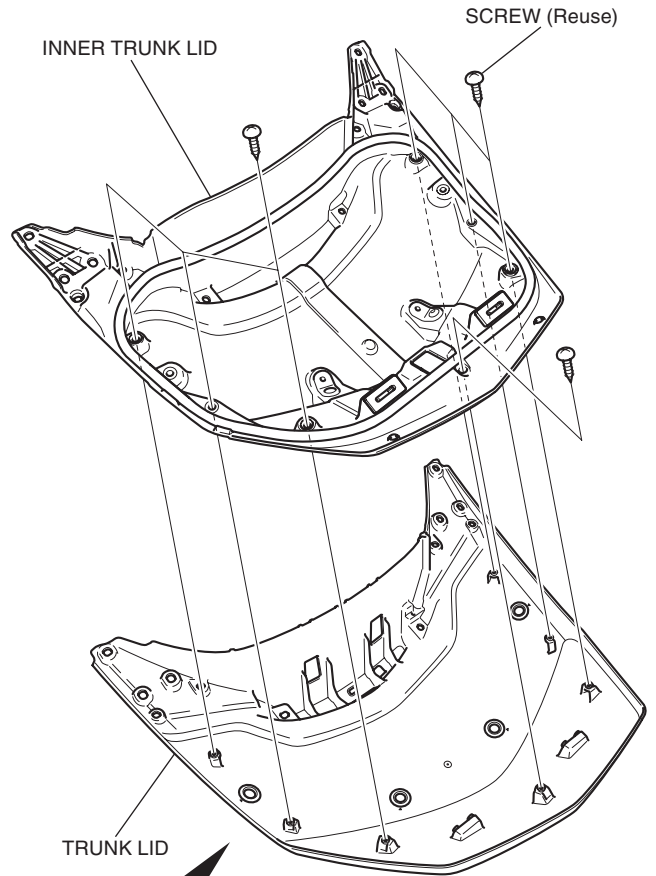

40. Install the striker rods as shown.

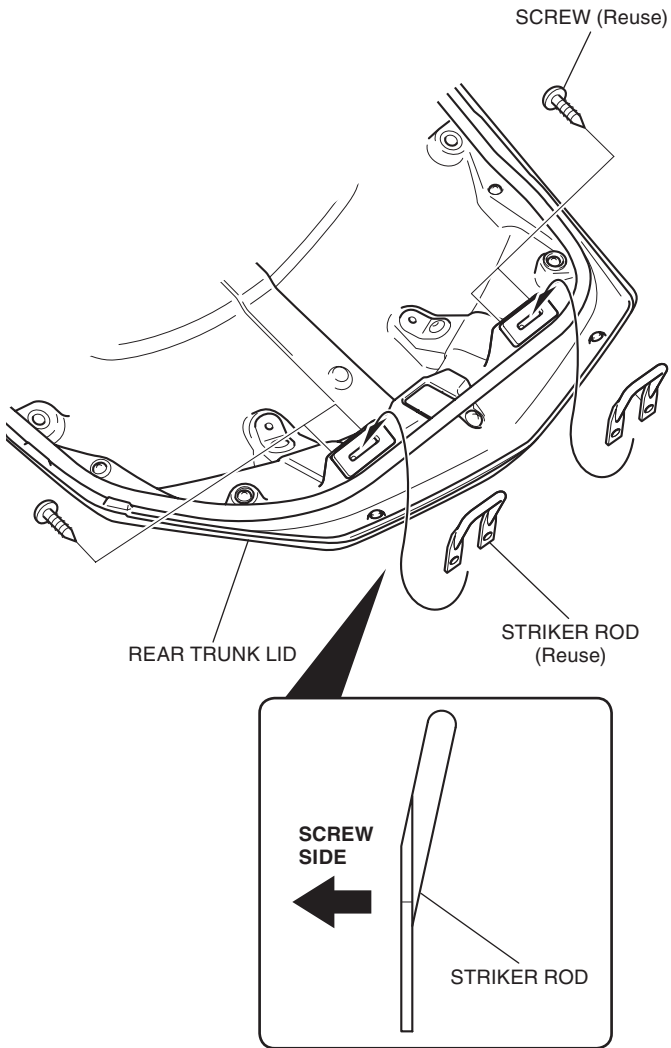

41. Install the left rack top cover as shown.

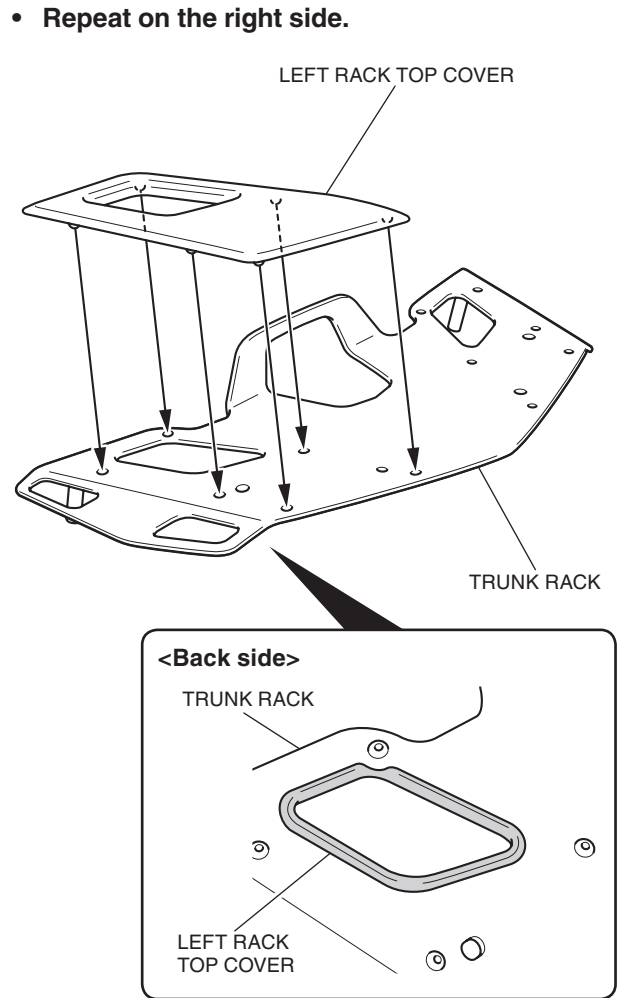

• Repeat on the right side.

42. Apply synthetic detergent solution to the position shown.

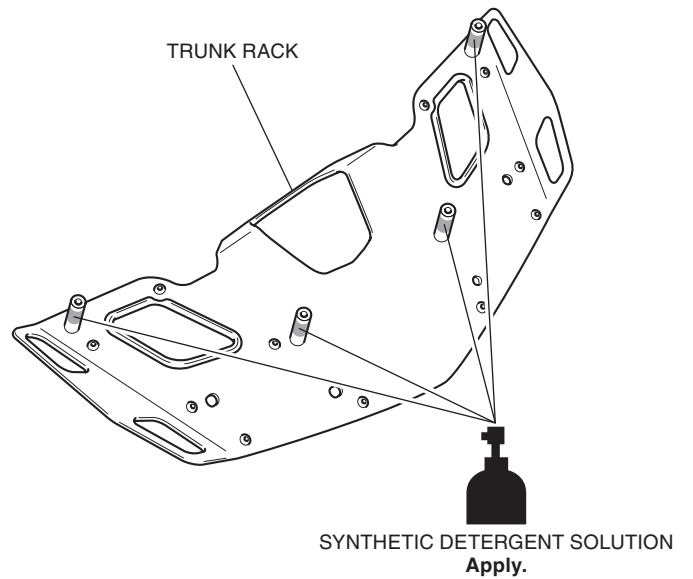

43. Install the trunk rack as shown.

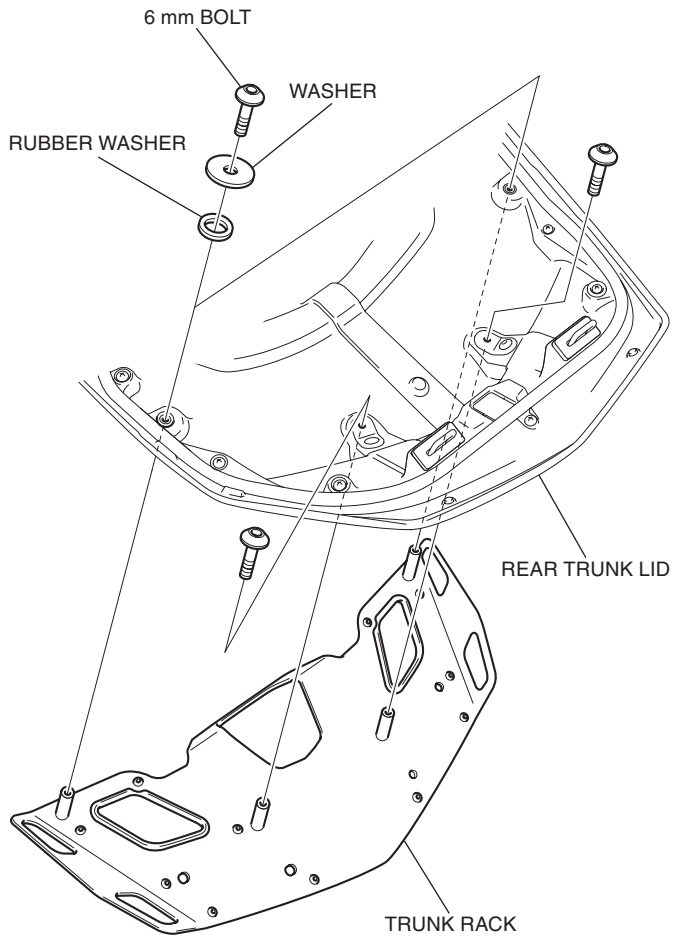

44. Install the rear trunk lid in the reverse order of removal.

45. Install the motorcycle's parts in the reverse order of removal.

- **Confirm that any wire harness is not caught or too tight.**