



INSTALLATION INSTRUCTIONS

Accessory
CENTER STAND
P/N 08M71-MKC-A00

Application
GL1800B/BD

Publication No.
MII
Issue Date
September 2017

Honda Dealer: Please give a copy of these instructions to your customer.

PARTS LIST

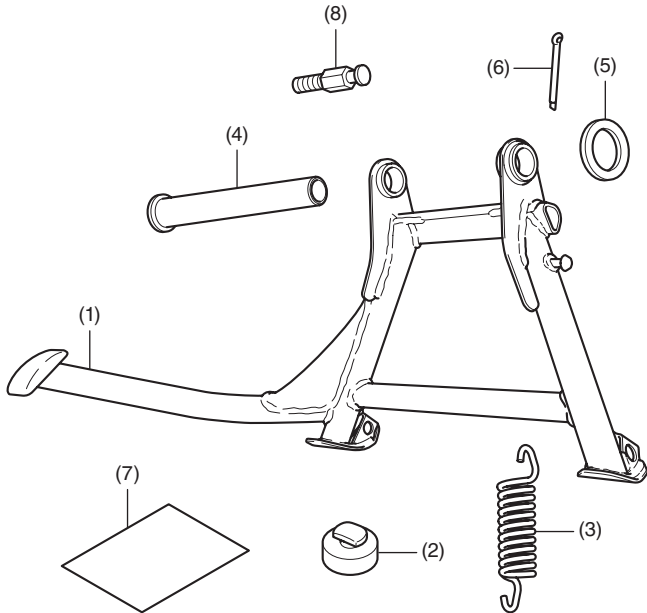

No.	Description	Qty
(1)	Center stand	1
(2)	Stand stopper rubber	1
(3)	Spring	1
(4)	Pivot pipe	1
(5)	Washer	1
(6)	Sprit pin	1
(7)	Installation Instructions URL	1
(8)	Spring hook	1

TOOLS AND SUPPLIES REQUIRED

- Box-end wrench (10 mm)
- Long nose pliers
- Spring tool
- Grease
- Synthetic detergent solution
(Water : Synthetic detergent / 100 : 1)
- Shop towel
- Torque wrench

TORQUE CHART

Tighten all screws, bolts, and nuts to their specified torque values. Refer to the Service Manual for the torque values of the removed parts.

Item	N·m	kgf·m	lbf·ft
Spring hook	22	2.2	16

INSTALLATION

▲ CAUTION

- To prevent burns, allow the engine, exhaust system, radiator, etc., to cool before installing the accessory.

NOTE:

- Be extremely careful when installing the spring as the combined tension of the spring is very strong.
- Keep the motorcycle on its side stand when installing the center stand.
- The spring installation shall be performed by two persons. While one person holds the motorcycle, another person installs the spring.

1. Remove the left saddlebag guard cover as shown.

<Left side>

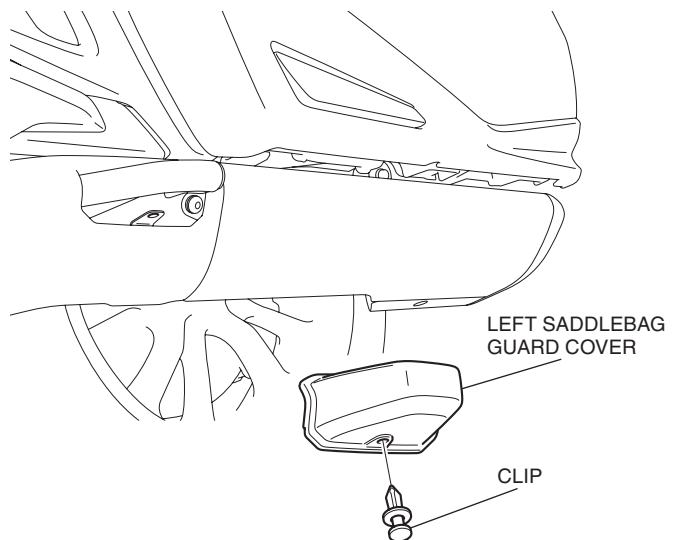

2. Remove the screw as shown.

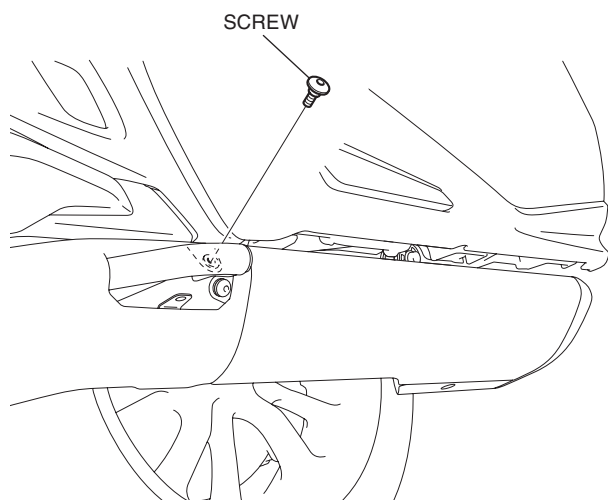

3. Remove the left exhaust pipe cover as shown.

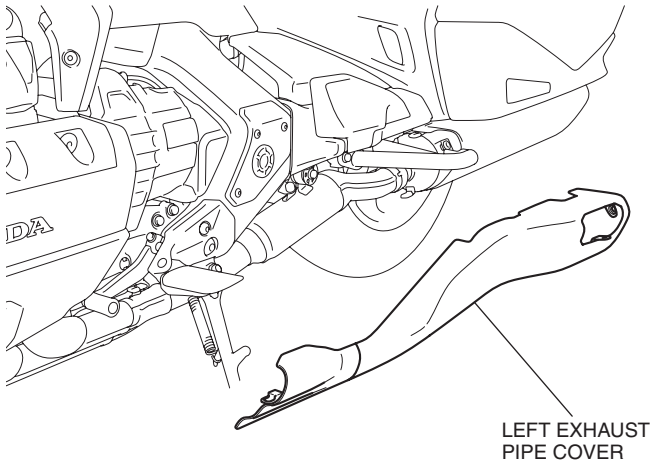

4. Remove the tube clamp as shown.

<Left side>

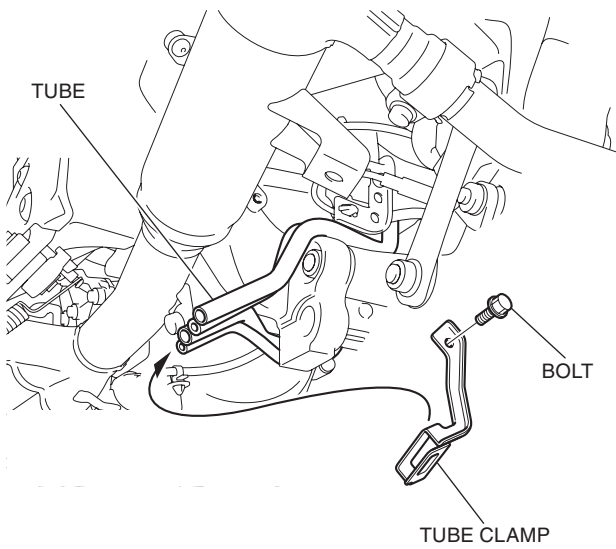

5. Apply synthetic detergent solution to the position shown.

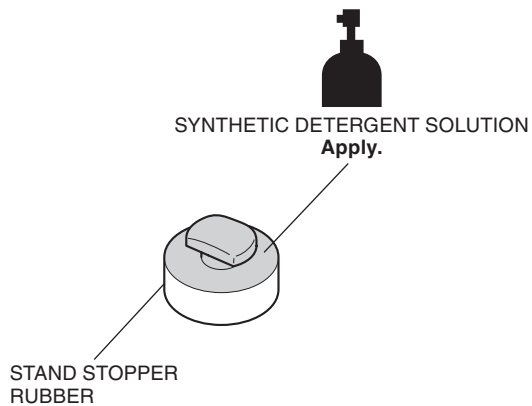

6. Install the stand stopper rubber as shown.

<Left side>

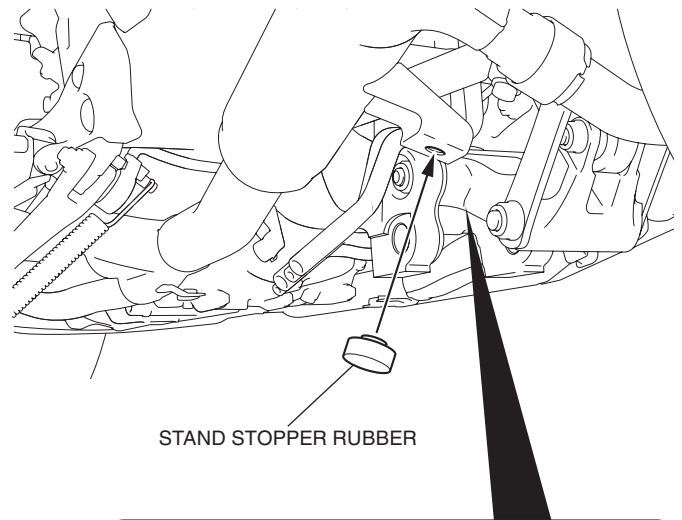

<Sectional view>

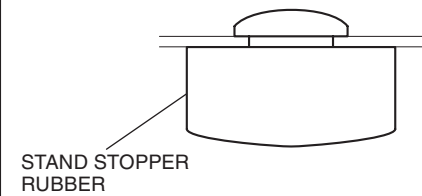

7. Apply grease to the position shown.

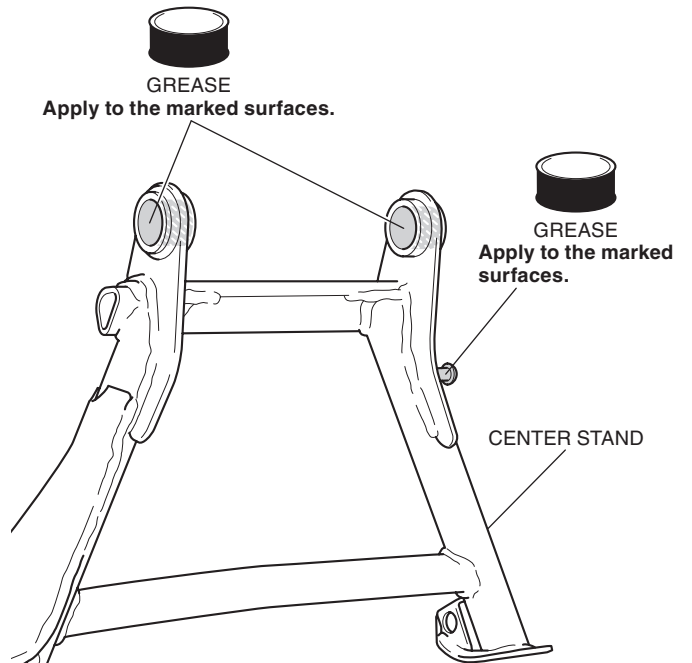

8. Install the center stand as shown.

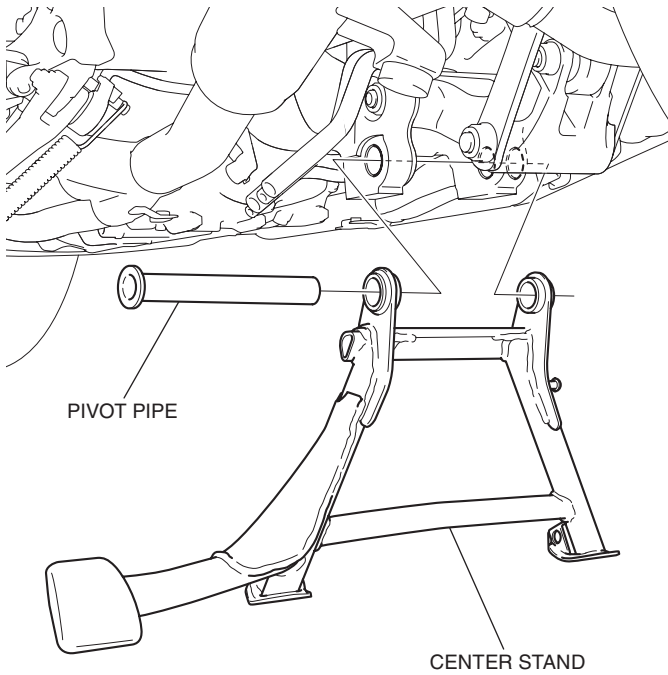

9. Install the washer as shown.
<Right side>

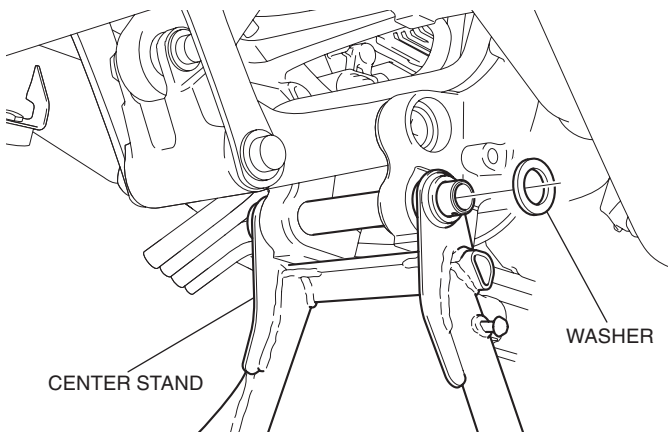

10. Install the split pin as shown.

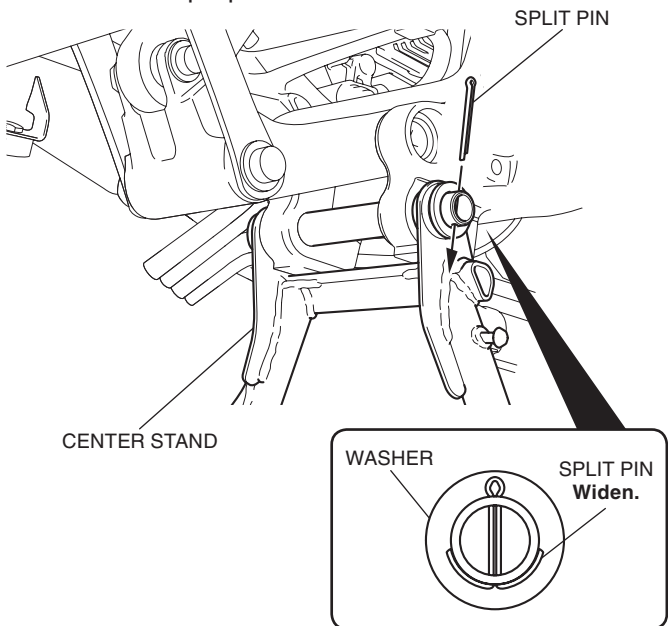

11. Install the spring hook as shown.

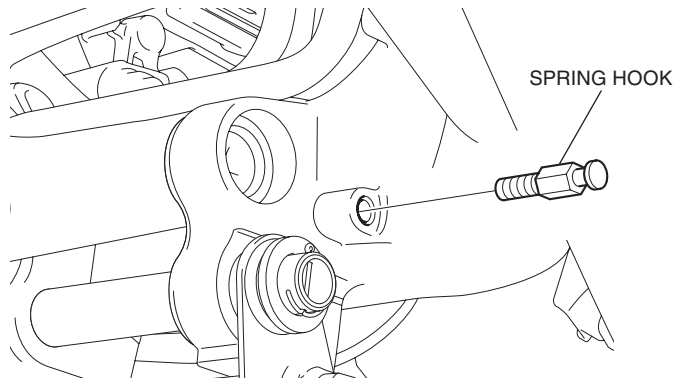

12. Apply grease to the position shown.

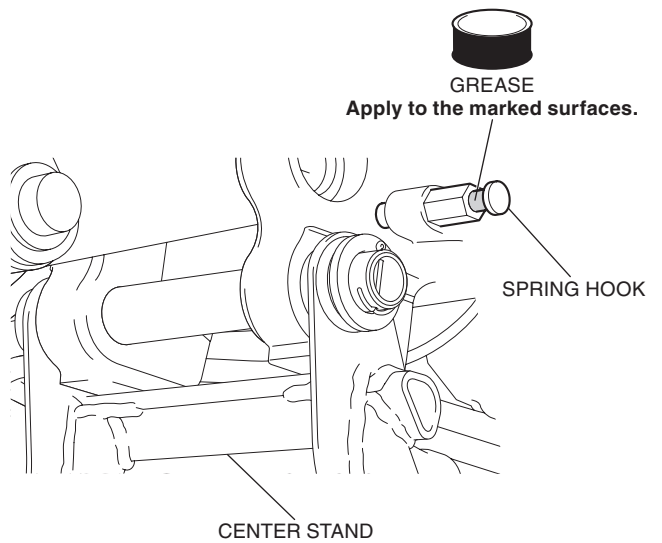

13. Install the spring as shown.

- The spring installation shall be performed by two persons. While one person holds the motorcycle, another person installs the spring.
- First install to the upper side spring hook, then install the spring on the center stand.

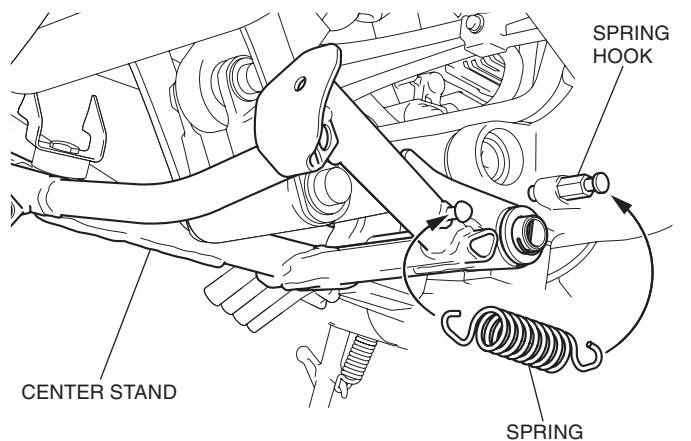

14. Install the motorcycle's parts in the reverse order of removal.