

Revised 9/8/2017

ITEMS REQUIRED:	#2 MEDIUM PHILLIPS SCREWDRIVER FLAT BLADED SCREWDRIVER HACKSAW BLADE FLAT FILE KNIFE	CYANOACRYLATE ADHESIVE (SUPER GLUE™) SMALL MARKING PEN CENTER PUNCH HAMMER 3/16" DRILL BIT AND ELECTRIC DRILL
-----------------	--	---

INSTALLATION:

1. REMOVE THE FOLLOWING:
 - A. PULL OUTWARD ON THE FAIRING FRONT COVER (1A) TO DISENGAGE THE BOSSES (1B) FROM THE FAIRING PANEL COVERS (2A).
 - B. USING THE FLAT BLADE SCREWDRIVER, PRY OFF THE L/R BLACK PLASTIC UPPER SIDE TRIM PIECES (2B).
 - NOTE: EACH SIDE HAS ONE LARGE AND ONE SMALL TRIM PIECE TO BE REMOVED.**
 - C. USING THE FLAT BLADE SCREWDRIVER, PRY OFF THE SCREW COVER (2C) FROM L/R LOWER FAIRING CORNER MOLDING TRIM (2D)
 - D. USING THE #2 PHILLIPS SCREWDRIVER, REMOVE THE SCREW (2E) FROM THE L/R LOWER FAIRING CORNER MOLDING TRIM PIECES (2D)
 - E. USING THE #2 PHILLIPS SCREWDRIVER REMOVE THE 3 SCREWS (2F) FROM THE L/R LOWER FAIRING PANEL COVERS (2A).
 - F. REMOVE THE L/R FAIRING PANEL COVERS (2A).

2. USING A HACKSAW BLADE, CUT OUT THE L/R KNOCKOUT PANELS (3A) USING THE MOLDED SLOTS (3B) AS AN OUTLINE. USING A FLAT FILE, SMOOTH THE CUT EDGES (4A) FLUSH WITH THE OPENING (4B).
3. PRESS THE RUBBER MOLDING (5A) ONTO THE EDGES OF THE OPENING (4B) STARTING AT THE BOTTOM CENTER (5B) AND WORKING IT ALL THE WAY AROUND THE OPENING, BEING CAREFUL NOT TO STRETCH THE MOLDING LENGTH. TRIM THE EXCESS LENGTH OFF TO MATE SQUARELY WITH THE OPPOSITE END.
4. CAREFULLY PULL THE INSIDE EDGE OF THE MOLDING (5A) AWAY FROM THE L/R COVER. APPLY A VERY SMALL AMOUNT OF CYANOACRYLATE (SUPER GLUE) ADHESIVE BETWEEN THE MOLDING AND THE INSIDE EDGE OF THE OPENING.

CAUTION: DO NOT GET ADHESIVE ON YOUR SKIN.

NOTE: IF YOU WOULD LIKE A SCREWLESS MOUNT YOU CAN USE EPOXY PLASTIC BONDER, AVAILABLE AT HARDWARE STORES, BUT BE SURE TO FOLLOW INSTRUCTIONS FOR EPOXY. (GLUING BRACKETS (6A) INSTEAD OF SCREW MOUNTING)

5. POSITION THE BRACKETS (6A) ON EITHER END OF THE L/R LIGHT OPENINGS, AND USING A MARKING PEN, MARK THE FOUR MOUNTING HOLES ON THE INSIDE OF THE L/R FAIRING PANEL COVERS (6B). CENTER PUNCH THE HOLE CENTERS WITH A HAMMER AND CAREFULLY DRILL THE FOUR L/R LIGHT HOLES USING 3/16" DRILL BIT AND ELECTRIC DRILL.
6. USING A #2 PHILLIPS SCREWDRIVER, INSTALL BRACKETS (7A) THROUGH THE HOLES DRILLED IN STEP #5, USING THE M4 X 10MM LONG TRUSS- HEAD MACHINE SCREWS (7B).
7. INSTALL THE L/R LIGHTS (7C) INTO THE L/R FAIRING SIDE COVERS (7D) BY SLIPPING THE PLASTIC TUBES (7E) OVER THE SPRINGS (7F) AND HOOKING THE SPRINGS ONTO THE BRACKET ENDS (7A) IN A CROSS OVER FASHION.
8. INSTALL THE SUPPLIED BULBS INTO EACH LIGHT HOUSING (7G) AND CONNECT THE FEMALE PLUGS TO EACH BULB. **NOTE: DO NOT TOUCH GLASS ON HALOGEN BULB WITH YOUR HANDS, USE A CLEAN CLOTH.**
9. PLUG THE JUMPER LOOP (8A) INTO THE 4-PIN PLUG (8E) (UNLESS YOUR BIKE IS A '98-2000 S.E. MODEL, THEN THE JUMPER IS NOT NEEDED).
10. CONNECT THE 2-PIN CONNECTOR (8F) INTO THE LIGHT PLUG (8G).

NOTE: THE GREEN PLUG IS FOR 1988-1997 MODELS AND THE WHITE PLUG IS FOR 1998-2000 MODELS.

NOTE: IF THE 2-PIN CONNECTORS DO NOT MATCH THE 2-PIN CONNECTOR ON THE BIKE, WE RECOMMEND YOU CUT OFF THE CONNECTORS AND SOLDER CONNECT THEM TOGETHER. MAKE SURE YOU MATCH THE WIRES CORRECTLY.

11. RE-INSTALL THE ITEMS REMOVED BY REVERSING STEPS 1A THROUGH 1F.

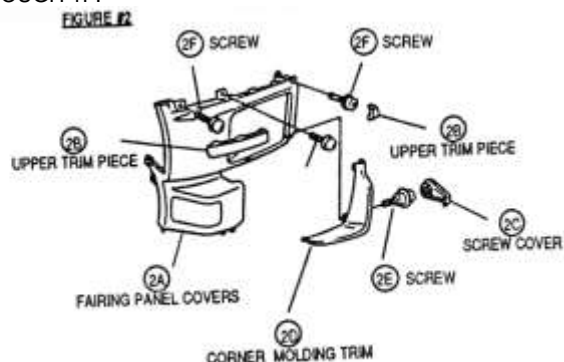
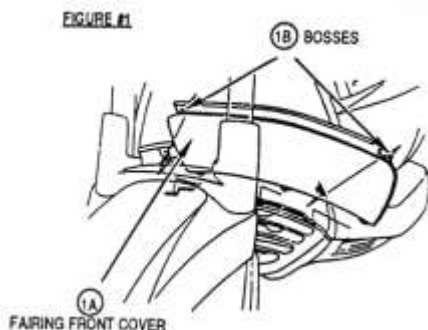

FIGURE #3

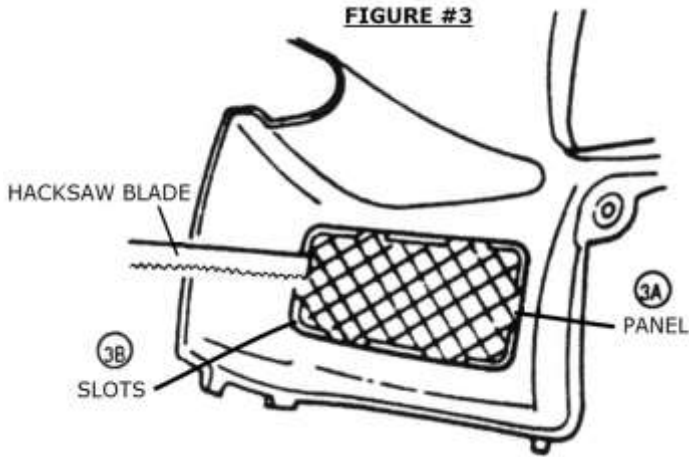

FIGURE #4

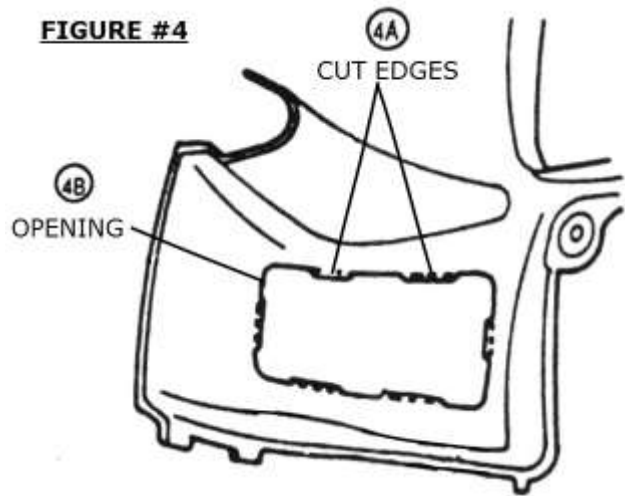

FIGURE #5

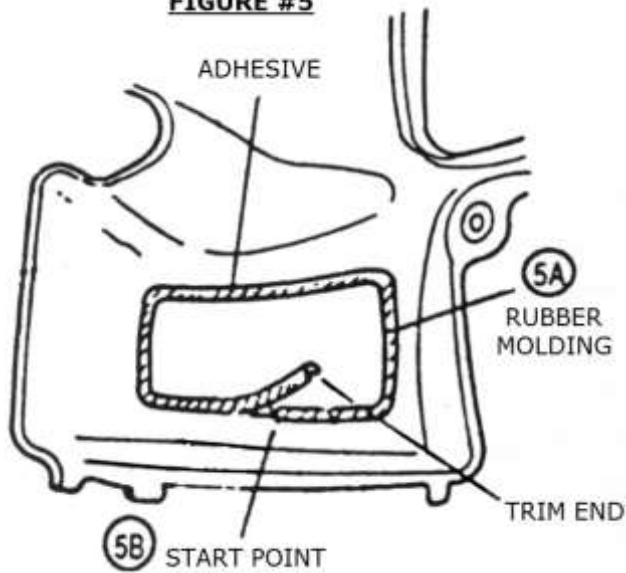

FIGURE #6

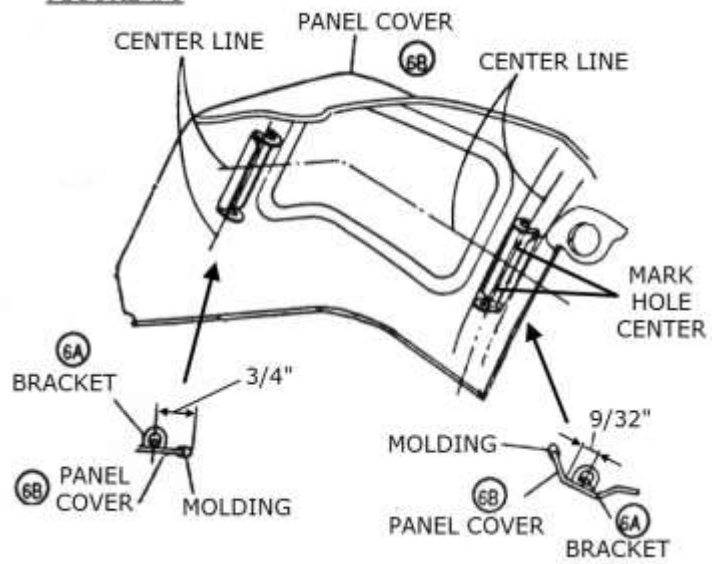

FIGURE #8

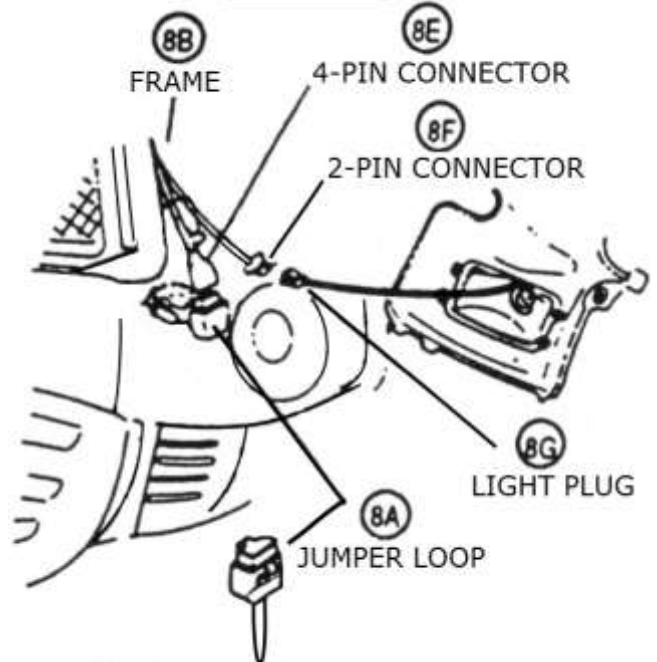

FIGURE #7

