

dimensioni Art. GSPA002P posto di lavoro centrale PANDORA CON PIANI INOX scala 1:20
 dimensions Art. GSPA002P styling unit PANDORA- STAINLESS STEEL SHELVES scale 1:20

formato

A4

1 praticare lo scasso a pavimento per murare a terra una scatola elettrica (ottimale una scatola 6 moduli, tipo BTICINO 506E)
perforate floor to enclose a shunt box (a 6 modules, like BTICINO 506E, is the best choice)

2 fare N° 4 fori nel pavimento per tasselli M8 lunghezza min. 100 mm o tasselli con ancorante chimico, qualora la pavimentazione non fosse sufficientemente compatta.
fare l'allacciamento elettrico tra il posto di lavoro ed i cavi di rete all'interno della scatola murata a pavimento
drill N° 4 holes in the floor to fit rawlplug for screws thread M8 minimum length 100 mm or chemical anchor blocks connect the styling station to the general power feeding inside the floor flush box

3 posizionare la base a terra, centrando i fori dei tasselli far scorrere la copertura della base verso l'alto, lungo il supporto del posto di lavoro
place the base on the floor, aligned with the plugs shift the metal cover upwards

4 fissare la base al supporto con 4 viti M6
fix the base to the stem with 4 screws m6

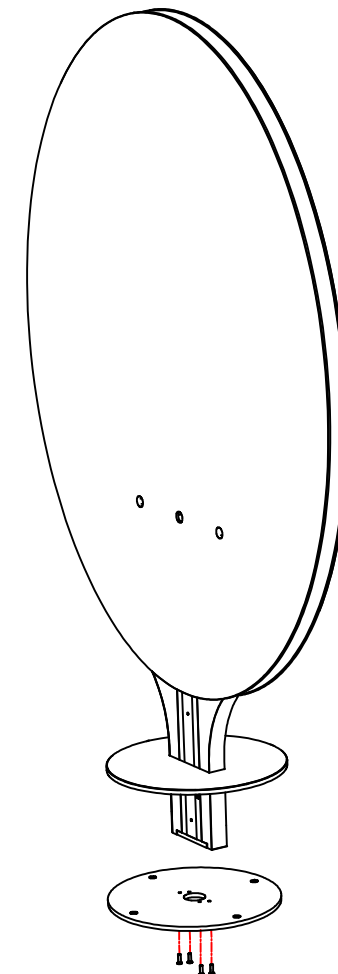
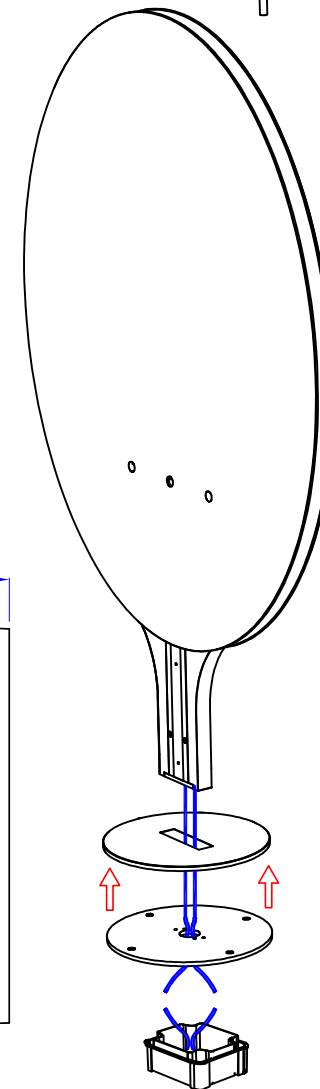
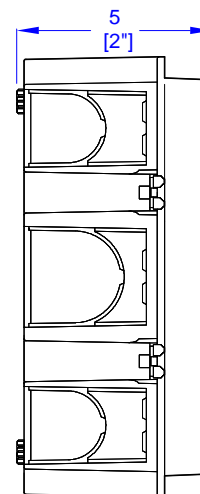
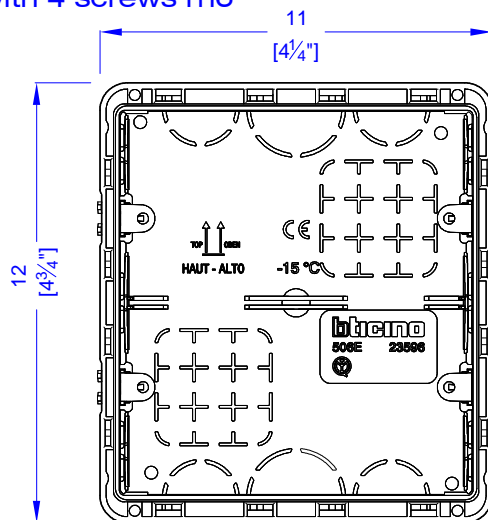
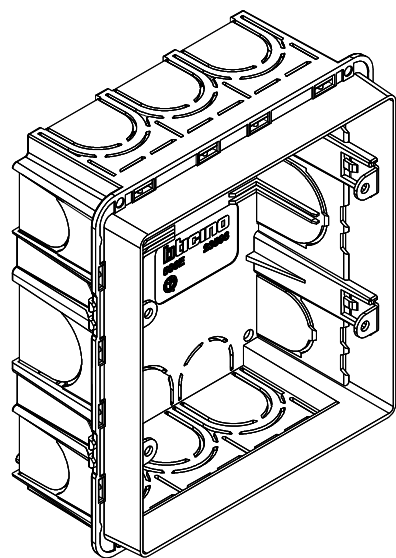
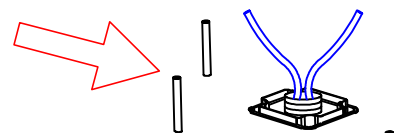

istruzioni montaggio Art. GSPA002P posto di lavoro centrale PANDORA scala 1:20
assembling instruction Art. GSPA002P styling unit PANDORA ISLAND scale 1:20

formato

A4

3

fissare la base a pavimento con 4 viti M8
lunghezza min. 100 mm
fix the base to the floor with screws thread M8
minimum length 100 mm

4

fissare le piastre di finitura con 2 viti M6 (sotto)
e 2 viti M5 (sopra)
fix the finishing plates with 2 screws thread M6 (lower holes)
and 2 screws thread M5 (upper holes)

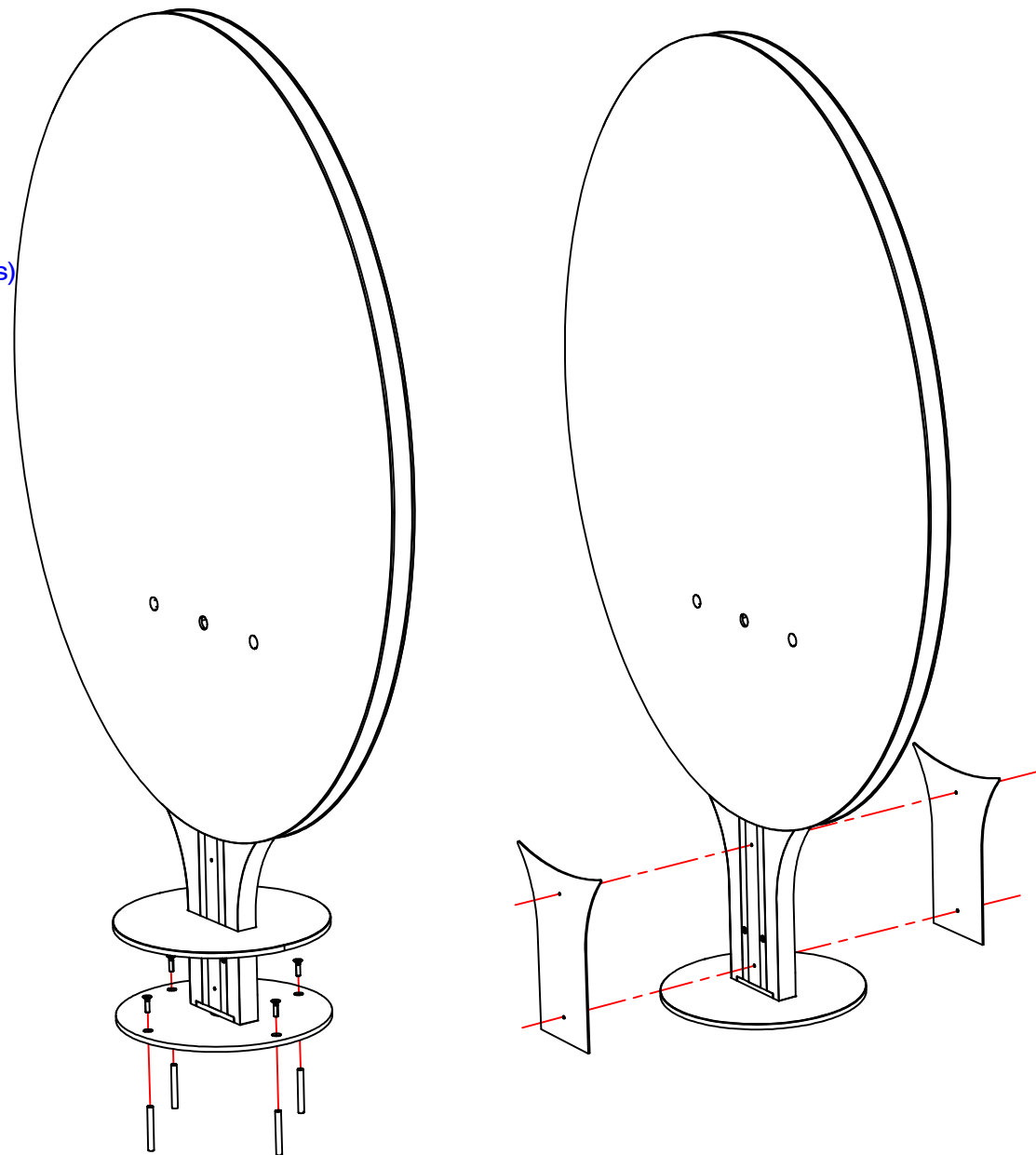

istruzioni montaggio Art. GSPA002P posto di lavoro centrale PANDORA scala 1:20
assembling instruction Art. GSPA002P styling unit PANDORA ISLAND scale 1:20

formato

A4

7 fissare i tondini filettati allo specchio mediante dadi
fix the threaded rods to the mirror with nuts

8 estrarre il cavo di connessione elettrica
dal foro nello specchio e cablare le prese
elettriche, che si trovano sulla faccia
inferiore dei piani di servizio
pull the electric wire out from the mirror
and connect the sockets, which are on
the lower side of the shelves

9 calzare i 2 piani di servizio sui tondini
slip the 2 shelves on the threaded rods

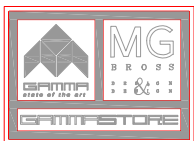
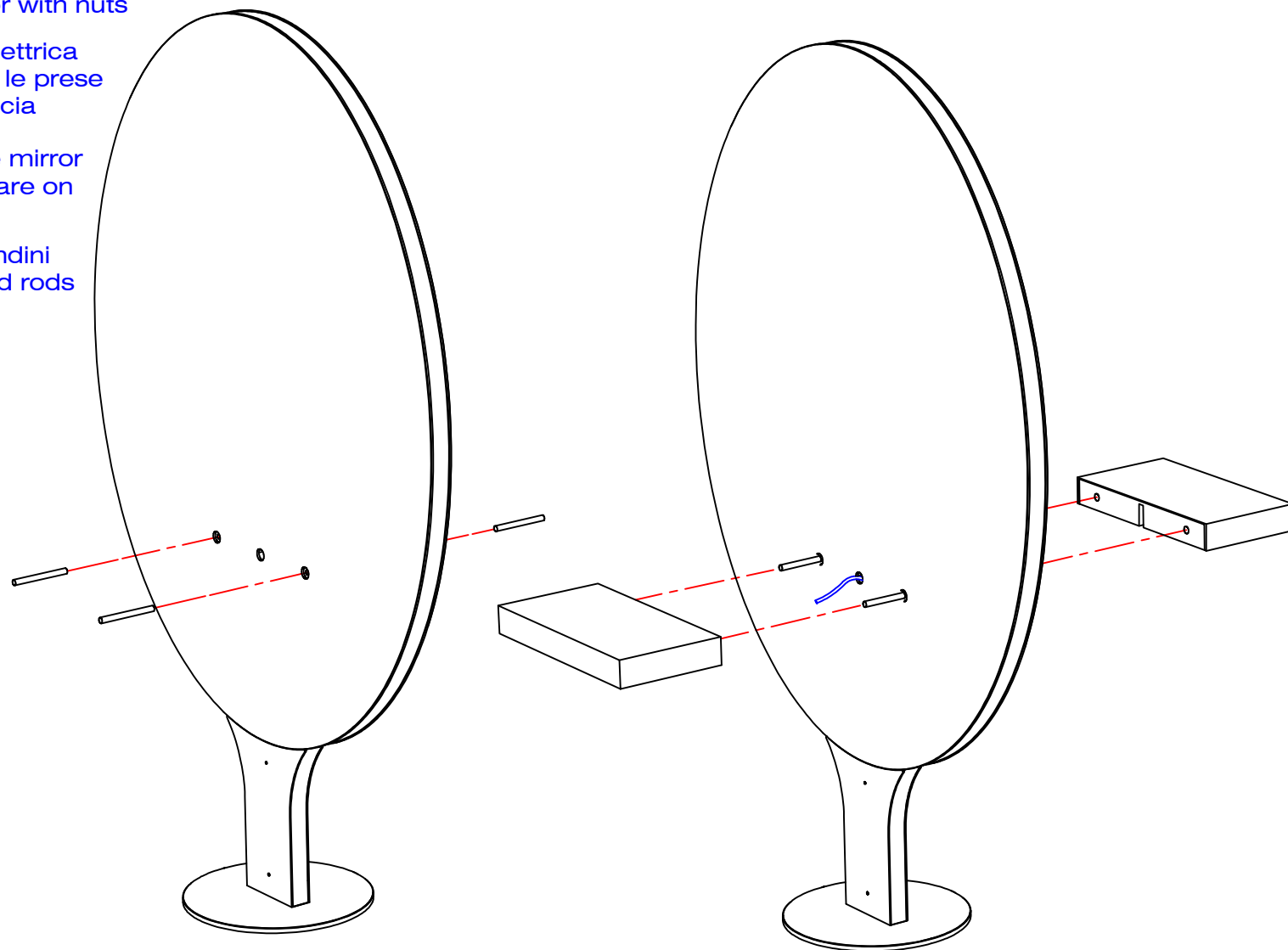
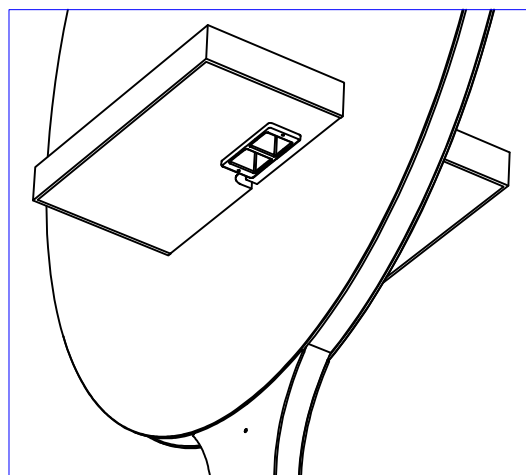

istruzioni montaggio Art. GSPA002P posto di lavoro centrale PANDORA scala 1:20
assembling instruction Art. GSPA002P styling unit PANDORA ISLAND scale 1:20

formato

A4

